

# IMPRESSIONS

03/2019



IMPRESSIONS

## WOLFGRUBER ITALY

via Campi della Rienza 15  
I-39031 Brunico (BZ)  
tel +39 0474 55 22 31  
fax +39 0474 55 22 47  
info@wolfgruber.it  
www.wolfgruber.it

## WOLFGRUBER GERMANY

tel +49 (0)89 5527 939 00  
fax +49 (0)89 5527 939 01  
info@wolfgruber.de  
www.wolfgruber.de

## WOLFGRUBER AUSTRIA

tel +43 (0)5337 64258  
fax +43 (0)5337 65451  
info@wolfgruber.at  
www.wolfgruber.at

## WOLFGRUBER FRANCE

tel +33 (0)975 129739  
info@wolfgruber.fr  
www.wolfgruber.fr

## COPYRIGHT

**it** Il presente catalogo è proprietà intellettuale della Wolfgruber Srl. La Wolfgruber Srl si riserva espressamente il diritto di proprietà e di autore delle informazioni contenute nel catalogo. La ristampa e la riproduzione, anche parziali, sono consentite solo previa autorizzazione scritta della Wolfgruber Srl.

**de** Dieser Katalog ist geistiges Eigentum der Wolfgruber GmbH. Die Wolfgruber GmbH behält sich das Eigentums- und Urheberrecht an den Katalogangaben ausdrücklich vor. Nachdruck und Vervielfältigung, auch auszugsweise, sind nur mit der vorherigen schriftlichen Genehmigung der Wolfgruber GmbH zulässig.

**en** This catalogue is intellectual property of Wolfgruber GmbH. The Wolfgruber GmbH expressly reserves the right of property and copyright of the contents published in the catalogue. Reproduction and duplication, either in extracts, are only permitted with the previous and written permission of the Wolfgruber GmbH.

**fr** La propriété intellectuelle de ce catalogue appartient à la sarl Wolfgruber. La société Wolfgruber se réserve expressément la propriété des droits d'auteur relatifs aux informations contenues dans le catalogue. La réimpression et la reproduction, même partielles, ne peuvent être autorisées qu'avec le consentement écrit de Wolfgruber.

## CHI È WOLFSGRUBER

**it** | La filosofia della ditta Wolfsgruber è di riconoscere e comprendere le esigenze del cliente sviluppando, dai suoi suggerimenti, prodotti nuovi unici nella loro funzione e forma. Tanti sono i riconoscimenti ricevuti nel tempo da una sempre più numerosa clientela, che apprezza un partner così flessibile, creativo e affidabile.

## ÜBER WOLFSGRUBER

**de** | Die Bedürfnisse des Kunden zu erkennen und zu verstehen, aus diesen Vorgaben innovative Produkte zu entwickeln, die in ihrer Form und Funktion einzigartig sind und somit einen hohen Wiedererkennungswert und Gebrauchswert erhalten, das ist die Philosophie von Wolfsgruber.

## ABOUT WOLFSGRUBER

**en** | The essential philosophy of Wolfsgruber centres around recognizing and understanding the needs of our customers, which inspires our continuous development of innovative products that are unique in form and function and are, as a result, highly recognizable and practical.

## QUI SOMMES NOUS?

**fr** | La philosophie de la société Wolfsgruber est de savoir identifier les besoins du client et développer à partir de ses suggestions des produits nouveaux dans leur fonction et leur forme. Flexibilité, créativité et fiabilité sont les qualités qui ont été largement reconnues par une clientèle toujours plus nombreuse.

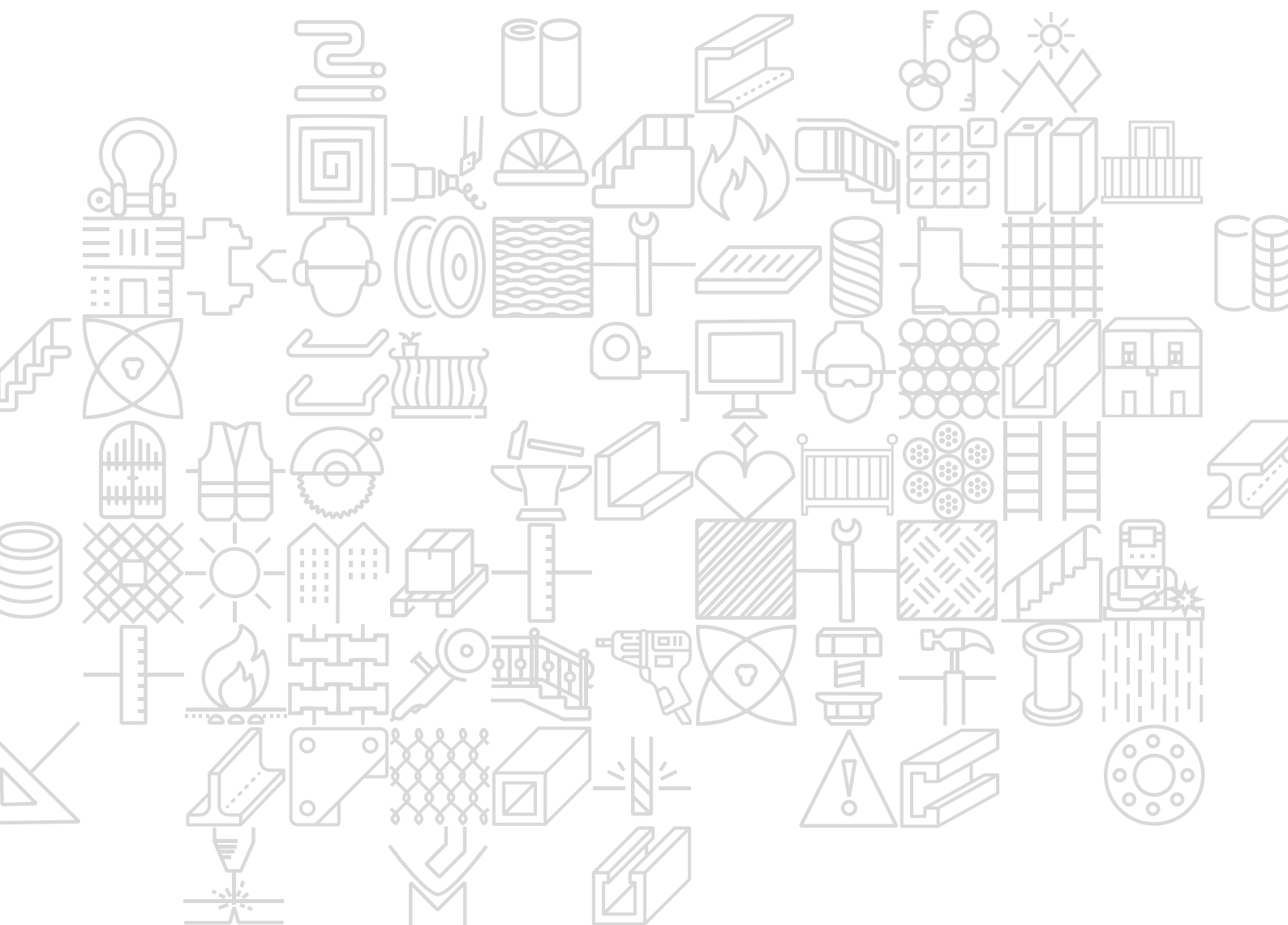



6

company



8

support



10

projects



14

basic



16

basic glass



18

basic glass plus



20

basic in axis



22

quadro



24

quadro glass



26

plate solutions



28

rope solutions



32

twin



34

twin plus



36

inox step system

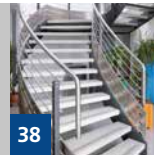

38

alu step system



40

laser - glass - curve - plus



46

simply glass



48

glass solutions



50

x-tend rope



52

x-tend frame



54

wrought iron

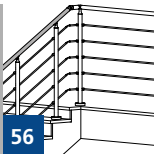

56

accessories

# Index

**01 company** | azienda | Firma | entreprise

**02 tube posts** | montanti in tubo | Rohrfosten | poteaux ronds

**03 plate posts** | montanti piatti | Flachpfosten | poteaux plat

**04 glass solutions** | soluzioni per vetro | Glaslösungen | solutions en verre

**05 x-tend** | rete | Netze | filets

**06 wrought iron** | ferro battuto | Schmiedeeisen | fer forgé

**07 accessories** | accessori | Zubehör | accessoires

## Dal 1972 il nome Wolfsgruber è sinonimo di affidabilità.

**it|** Dal laboratorio per la lavorazione artistica del metallo, fondato da Klaus Wolfsgruber, è nata un'azienda moderna, al passo con i tempi. Nonostante l'utilizzo di macchinari all'avanguardia, l'abilità artigianale e le soluzioni individuali sono ancora oggi al primo posto.

## Seit 1972 steht der Name Wolfsgruber für Zuverlässigkeit und Qualität.

**de|** Aus der von Klaus Wolfsgruber gegründeten Kunstschmiede entstand im Laufe der Zeit ein modernes Produktionsunternehmen. Trotz Einsatz modernster Maschinen wird jedoch auch heute noch handwerkliches Können und Individualität groß geschrieben.



## The name Wolfsgruber has stood for reliability and quality since 1972.

**en** | A modern production enterprise has over time developed from the artistic forge created by Klaus Wolfsgruber. Craftsmanship and individuality are still highly prized and co-exist alongside the latest machinery.

## Depuis 1972 le nom Wolfsgruber est synonyme de fiabilité.

**fr** | Du petit atelier de ferronnerie d'art, fondé par Klaus Wolfsgruber, est née une entreprise moderne, en phase avec son temps. Bien que nous utilisions des machines d'avant-garde, le savoir-faire artisanal et les solutions individuelles occupent encore aujourd'hui la première place.





# Support





**it** Fin dall'inizio di un progetto siamo alla Vostra completa disposizione: Vi diamo un supporto tecnico completo dalla progettazione fino alla produzione dei particolari secondo le Vostre idee. Per reagire in modo sempre più flessibile e veloce alle vostre esigenze, il nostro parco macchine viene ampliato continuamente con tecnologia all'avanguardia.

**de** Von Anfang an unterstützen wir Sie konsequent bei der Umsetzung Ihrer Vorstellungen: wir helfen ihnen bei der Ausarbeitung von Projekten, beraten sie in technischen Fragen und produzieren alle Teile nach Ihren Vorstellungen. Um immer flexibler und schneller auf Anfragen von Sonderanfertigungen reagieren zu können, wird unser Maschinenpark ständig erweitert. Dabei werden laufend neue Technologien eingesetzt, die eine wirtschaftliche Produktion ermöglichen.

**en** From the outset we consistently support you in realizing your individual ideas. We help you with the expansion of your products, consult you with technical related questions and produce each part according to your ideas. To react flexibly and speedily to your inquiries and special designs, our plant is constantly expanding. Therefore we deploy new technologies which enable an efficient production.

**fr** Notre gamme d'accessoires inox offre des possibilités sans fin. Pour répondre aux attentes de l'architecture moderne nous avons créé, grâce à l'expérience acquise depuis des années, un programme complet d'éléments inox fabriqués à l'aide de technologies avant-gardistes.



Abbildung 6.5: Lastfall A: Vergleichsspannung





# Projects

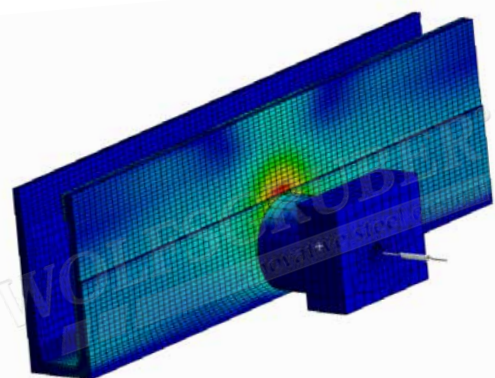

**it|** Wolfsgrubber è a vostra disposizione sia per risolvere i problemi legati alla progettazione della scala o del parapetto, che per esigenze funzionali e/o architettoniche. Se non riuscite a realizzare il vostro progetto attraverso la gamma di articoli standard, inviate la richiesta al nostro ufficio tecnico specificando più dettagli possibili: siamo in grado di guidarvi verso la soluzione più idonea sotto il profilo estetico e funzionale. Con il suo team di esperti, Wolfsgrubber può curare l'installazione dei materiali direttamente in cantiere.

**de|** Unsere Techniker stehen Ihnen bei der Planung Ihres Projektes gerne zur Seite: egal ob es sich um besondere Anforderungen funktioneller oder architektonischer Natur handelt. Senden Sie uns Ihre Anfrage und wir finden gemeinsam die passende Lösung, um jederzeit die optimale Ausführung zu garantieren, die Ihren optischen und technischen Anforderungen entspricht. Für Montageeinsätze steht Ihnen unser technisch geschultes Personal zur Verfügung.

**en|** You can rely on our technician's support if you have special requirements in functional or of a formal nature, which are achievable through special design or with our standard products. Send us your request and we will find the right solution to guarantee optimum performance, which suits your visual and technical needs. For your desired project our technical skilled personnel is at your disposal.

**fr|** Wolfsgrubber est à votre disposition soit pour résoudre les problèmes liés au projet d'escaliers ou garde corps, soit pour les exigences fonctionnelles ou architectoniques. Si vous ne pouvez pas réaliser votre projet avec des produits de la gamme standard, envoyez une demande à notre bureau technique en donnant tous les détails: nous vous guiderons vers la solution la plus adaptée alliant le côté esthétique et fonctionnel. Avec son équipe d'experts, Wolfsgrubber peut prendre en charge l'installation du matériel sur le chantier.









# basic

## VERSATILE

**it** Il più versatile dei nostri modelli è senza dubbio il sistema BASIC. Questo classico modello consiste in piantoni in tubo tondo con cinque o otto traverse ancorate frontalmente sul piantone tramite fissaggi cilindrici.

## VIELSEITIG

**de** Das für alle Treppentypen anwendbare Modell BASIC besteht aus runden Pfosten und ist unser vielseitigstes Geländermodell. In der klassischen Variante werden fünf oder acht Querstäbe, gehalten von Querstabhaltern, an der Vorderseite des Pfostens montiert.

## ALL-ROUND

**en** Best suited for all kind of stairs the BASIC model is made of round tubes and is our most versatile baluster post.

The plain classical model is supposed to be mounted with cross bar holders on the front of the baluster and filled with five or eight cross bars.

## POLYVALENT

**fr** Le modèle BASIC, adapté pour tout type d'escalier, est le plus polyvalent de la gamme. Il est composé de poteaux ronds avec, pour la variante classique, un remplissage de 5 ou 8 lisses montées sur le devant des poteaux au moyen de supports.







# basic glass

## COMBINATO

**it|** I modelli BASIC GLASS e BASIC GLASS PLUS consistono in piantoni di tubo tondo e morsetti per vetro. Oltre al riempimento con solo vetro si realizza anche la combinazione vetro con traverse. La specifica costruzione di questi ultimi parapetti permette l'impiego in luoghi frequentati da bambini, in quanto non sono scalabili.

## KOMBINIERT

**de|** Die Modelle BASIC GLASS und BASIC GLASS PLUS bestehen aus runden Pfosten und Glasklemmen. Glas kombiniert mit Querstäben oder auch reine Glasfüllungen sind bei diesem Modell denkbar. Beide Varianten sind äußerst kindersicher, da keine Klettermöglichkeiten bestehen.

## COMBINED

**en|** BASIC GLASS and BASIC GLASS PLUS are made of round railing posts and glass clamps. Glass combined with cross bars or complete glass-fields are possible in this case. Both models are very safe referring the child-resistance as children cannot climb onto any cross bars.

## COMBINE

**fr|** Les modèles BASIC GLASS et BASIC GLASS PLUS sont composés de poteaux ronds et de pinces à verre. Deux types de remplissage sont possibles: entièrement en verre ou verre combiné avec des lisses. Les deux versions sont particulièrement sûres pour les enfants du fait de l'impossibilité d'escalade.





# basic glass plus





# basic in axis

## MINIMALISTA

**it** | Il modello BASIC IN AXIS è costituito da piantoni in tubo tondo, con traverse che trapassano direttamente il piantone tramite delle forature passanti. Ridotto al minimo indispensabile, questo modello convince per il suo aspetto sobrio e lineare, oltre che economico.

## MINIMALISTISCH

**de** | Das Modell BASIC IN AXIS besteht aus runden Pfosten und kommt ohne zusätzliche Querstabhalter aus. Die Querstäbe werden direkt durch die Pfosten geführt, wodurch ein schlichtes Design entsteht.

## MINIMALIST

**en** | The BASIC IN AXIS system consists of round tubes and doesn't need additive cross bar holders. The cross bars are led directly through the railing posts. Therefore this model has a very flat and simple design.

## MINIMALISTE

**fr** | Le modèle BASIC IN AXIS est composé de poteaux ronds et de lisses traversantes, sans ajout de supports de lisse. L'atout de ce modèle est de ce fait la sobriété de son design.





# quadro

## SQUADRATO

**it** | Il design squadrato è l'attributo caratteristico del sistema QUADRO. Si abbina perfettamente alle architetture moderne in sostituzione della classica ringhiera tonda. Un alto livello di sicurezza e allo stesso tempo di trasparenza è garantita dal riempimento con cinque o otto traverse.

## ECKIG

**de** | Das Modell QUADRO überzeugt durch sein eckiges Design. Ideal für den Einsatz in modernen Objekten als Alternative zu den klassischen runden Geländermodellen. Für genügend Durchblick und Sicherheit sorgen die luftigen Querstab-Geländervarianten aus fünf oder acht Querstäben.

## ANGULAR

**en** | In contemporary architecture the model QUADRO is convincing with its squared design. It is the perfect alternative to round classic posts. Use a light model with five or eight bars which offers you security and transparency at the same time.

## CARRÉ

**fr** | Le modèle QUADRO est caractérisé par un design carré qui constitue une alternative contemporaine au classique garde-corps rond. Grâce à sa possibilité de remplissage à cinq ou huit lisses, il offre un haut niveau de sécurité, ainsi que de la transparence.







# quadro glass

## MODERNO

**it|** Anche in combinazione con il vetro, il nostro modello QUADRO GLASS è convincente: si inserisce al meglio nella moderna architettura acciaio-vetro.

## MODERN

**de|** Kombiniert mit Glas überzeugt unser GeländermodeLL QUADRO GLASS durch sein eckiges Design. In der modernen Stahl-Glas-Architektur fügt sich dieser Geländertyp optimal ein.

## MODERN

**en|** Combined with glass our QUADRO GLASS model is geometric in design and fits perfectly well into the modern steel-glass architecture.

## MODERNE

**fr|** Notre modèle QUADRO GLASS au design carré s'intègre parfaitement dans l'architecture moderne qui combine l'acier et le verre.

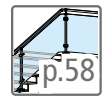



# plate solutions

## PRATICO

**it** | Le nostre ringhiere con riempimento in lamiera offrono un rapporto prezzo/utilità eccezionale. Si distinguono soprattutto in un ambiente architettonico funzionale e moderno.

## PRAKTISCH

**de** | Durch ein außergewöhnliches Kosten-Nutzen-Verhältnis zeichnen sich Geländer mit Blechfüllung aus. Dabei machen Sie vor allem in einem architektonisch-modernen Umfeld eine gute Figur.

## PRACTICAL

**en** | Railings with plate fillings feature a remarkable cost-benefit ratio. With an individual pattern they make a good figure in architectural and modern surroundings.

## PRATIQUE

**fr** | Nos garde-corps avec remplissage en tôle ont un rapport qualité-prix exceptionnel. Ils sont particulièrement adaptés à un environnement architectural fonctionnel et moderne.





# rope solutions

## ALTERNATIVO

**it** | Una valida alternativa alla classica ringhiera con tondi trasversali si trova nel utilizzo delle funi. La ringhiera allestita in questo modo presenta un aspetto ancora più leggero e trasparente. La particolare estetica delle funi, la rende ideale sia per un ambiente moderno sia tradizionale.

## ALTERNATIV

**de** | Als Alternative zu den traditionellen Querstäben wirken Seile als Geländerfüllung leichter und noch transparenter. Seine Vorteile spielt dieses Geländermodell in einem modernem oder traditionellem Umfeld aus.

## ALTERNATIVE

**en** | Ropes as railing infills are a lighter and more transparent alternative to conventionally used cross bars. Rope solutions show their advantages in modern and traditional ambiances.

## ALTERNATIVE

**fr** | Les câbles représentent une alternative de remplissage de garde-corps plus légère et transparente que les lisses traditionnelles. Les atouts de ce modèle sont valorisés dans un contexte moderne aussi bien que rustique.







TRUBER®  
innovative steel design





# twin

## SNELLO

**it|** All' insegna della eleganza nasce il modello TWIN. Come implica il nome, il design si basa su due piatti che accolgono internamente le traverse, garantendo un impiego funzionale e lineare.

## SCHLANK

**de|** Dem Modell TWIN liegt ein sehr elegantes und funktionelles Design zugrunde. Wie der Name TWIN vermuten lässt, handelt es sich hierbei um einen zweiteiligen Geländerpfosten, durch dessen Mitte die Querstäbe geführt werden.

## SLIM

**en|** The TWIN model has got an elegant and functional design. Already the name TWIN implicates its construction which is a slim two-parted baluster. Cross bars are led directly between both flat irons.

## FIN

**fr|** Le modèle TWIN présente un design élégant et fonctionnel. Le nom TWIN évoque la conception basée sur des poteaux double plat, reliés par des lisses traversantes.





# twin plus

## DISTANZIATO

**it|** Il modello TWIN PLUS è una variante del modello TWIN. I distanziali tra i due piatti che accolgono le traverse creano un design più robusto e massiccio, senza rinunciare all'aspetto elegante della serie TWIN.

## DISTANZIERT

**de|** Das Modell TWIN PLUS ist eine erweiterte, breitere Variante des TWIN Modells und ist hervorragend für den schrägen Treppenbereich geeignet. Durch den Einsatz von zusätzlichen Abstandhaltern, durch die die Querstäbe hindurchgeführt werden, ergibt sich ein massiveres Erscheinungsbild des Geländers.

## SPACED OUT

**en|** The TWIN PLUS model is a modified and widened version of the TWIN model and is ideally suitable for diagonal usage. Additional spacers fitted between the two flat irons give this post a sturdier look. A robust model which has cross bars led through the spacers.

## ESPACÉ

**fr|** Le modèle TWIN PLUS est la variante plus large et espacée du TWIN. Elle est idéale pour les parties inclinées des escaliers. L'utilisation de supports additionnels traversés par les lisses donne à l'ensemble un design plus massif, sans renoncer à l'élégance de la série TWIN.





# inox step system

## FLESSIBILE

**it|** Caratteristica principale del modello INOX STEP SYSTEM è la sua estrema versatilità: secondo la propria fantasia vari elementi possono essere posizionati a libera scelta. Come riempimento si possono impiegare tondi, quadri o piatti senza rinunciare alla opzione vetro. In più, tutte queste soluzioni sono combinabili tra loro, creando così una ringhiera originale e personalizzata.

## FLEXIBEL

**de|** Das Modell INOX STEP SYSTEM besticht durch seine hohe Flexibilität, ermöglicht durch die beliebige Aufteilung der Geländerfüllung. Die Zubehörteile sind frei positionierbar, sowie problemlos in der Länge anzupassen. Als Füllung bieten sich Rundstäbe, Quadratprofile, Flachprofile, Glas oder auch deren Kombinationen, wodurch ein individuelles Geländer zusammenstellbar ist.

## FLEXIBLE

**en|** INOX STEP SYSTEM is highly flexible. Quantity and position of the accessories can be varied according to customer's choice. Available fillings are round tubes, squared or flat profiles, glass fillings as well as a combination of them which offers you to design your individual railing!

## FLEXIBLE

**fr|** La caractéristique principale du modèle INOX STEP SYSTEM est sa flexibilité, du fait de ses multiples possibilités de remplissage. Les composants peuvent être placés librement et adaptés facilement en longueur. Ce modèle permet un remplissage en lisses rondes, carrées, plates ou en verre, ainsi que leurs combinaisons, ce qui consent un degré élevé de personnalisation.



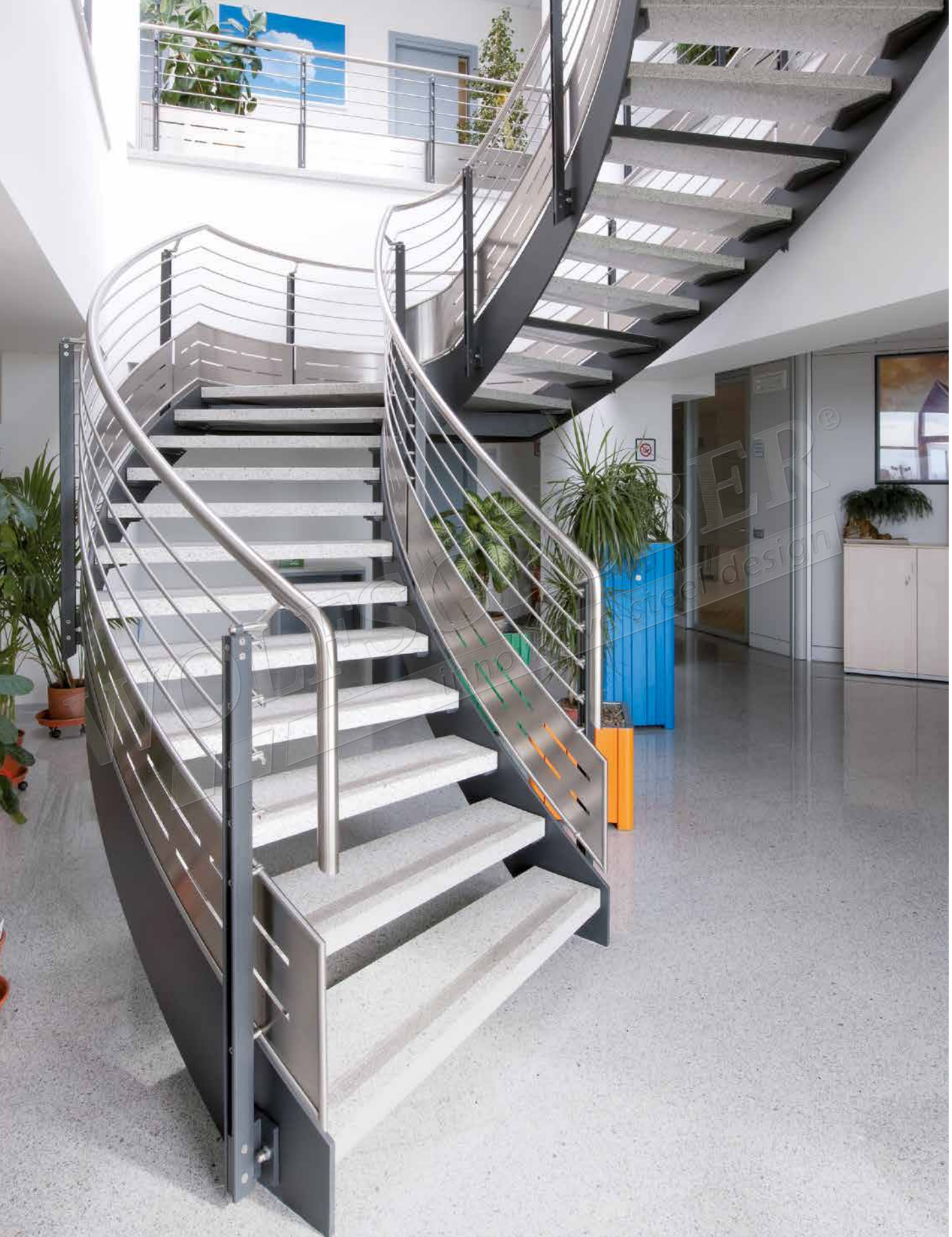

# alu step system

## INDIVIDUALE

**it|** Il modello ALU STEP SYSTEM prevede un piantone composto da un doppio profilo in alluminio verniciato a polvere. I vari riempimenti si possono posizionare liberamente sul piantone. La gamma dei possibili riempimenti comprende traversi in tondo, quadro o piatto, vetro o funi. I montanti sono fornibili anche con diversi colori per offrire una ringhiera personalizzata al massimo.

## INDIVIDUELL

**de|** Das Modell ALU STEP SYSTEM besteht aus pulverbeschichteten Alu-Spezialprofilen. Beliebige Aufteilung der Geländerfüllung aufgrund frei positionierbarer Zubehörteile, sowie die Wahl der Füllung mit Kantprofilen, Seilen oder Glaselementen ermöglichen eine individuelle Geländervariante. Auch in anderen Farben lieferbar.

## CUSTOM

**en|** ALU STEP SYSTEM is made of powder-coated aluminum profiles. The position of various accessories can be varied according to customer's choice. Fillings as squared profiles, ropes or glass elements are available and allow you to design an individual railing. Other colors upon request.

## PERSONNALISABLE

**fr|** Le modèle ALU STEP SYSTEM est constitué de profils spéciaux en aluminium avec revêtement en poudre. De nombreuses variantes de garde-corps sont possibles du fait de la liberté de placer les composants et du grand choix au niveau du remplissage entre profils carrés, câbles et éléments en verre. Disponible en plusieurs coloris.







# laser



## ROBUSTO

**it|** I modelli LASER sono una opzione economica per le ringhiere esterne. Il design dinamico si esalta in un contesto di architettura moderna. La produzione automatizzata su un impianto taglio laser a gestione interamente computerizzata rende possibile la fornitura di piantoni sagomati a richiesta con misure a piacere.

## ROBUST

**de|** Die Modelle LASER sind eine kostengünstige Lösung für Außengeländer. Die dynamische kantige Form des Geländers ist der Hingucker im Umfeld eines modernen Außenbereiches. Maschinell gelasert, ist das Modell beliebig in Form und Materialstärke anpassbar.

## ROBUST

**en|** Our LASER model is the affordable solution for open-air railings. With its dynamic and fresh shape this model is the eye-catcher in modern architecture. Computer-lasered this model is customizable in shape and thickness.

## SOLIDE

**fr|** Les modèles LASER représentent une solution économique pour les garde-corps d'extérieur. Leur design d'impact s'insère bien dans l'architecture moderne. La découpe automatisée par commande numérique permet d'obtenir des pièces sur mesure en termes de forme et d'épaisseur.



# laser curve



# laser glass





# laser plus

## SLANCIATO

**it|** Il design slanciato del modello LASER, arricchito con una innovativa soluzione a boccia sferica, fanno sì che il modello LASER PLUS si presti idealmente per le ringhiere inclinate.

Il modello LASER GLASS mostra un riempimento trasparente di vetro leggermente inclinato creando così un design raffinato e dinamico.

## SCHNITTIG

**de|** Das schnittige Modell LASER wird in der LASER PLUS Variante um eine kugellagerartige Durchgangshülse für die Querstäbe erweitert und eignet sich so perfekt für den schrägen Treppenbereich.

Mittels Glasklemmen werden beim LASER GLASS Modell die schrägen Glaselemente gehalten und verleihen der Atmosphäre Dynamik und Frische.

## SMART

**en|** The smart modified version of this LASER model is equipped with an adjustable ball bearing for its cross bars. Therefore it is ideally used for stairways. Dynamic shapes and the fresh appearance of glass elements held by clamps are united in the LASER GLASS model.

## ELEGANT

**fr|** Au design élégant du modèle LASER s'ajoute, dans la variante LASER PLUS, une rotule sphérique pour supports de lisse, ce qui la rend adaptée aux escaliers / garde-corps inclinés. Dans le modèle LASER GLASS, les éléments en verre inclinés, fixés au moyen de pinces, contribuent à un design dynamique et innovant.



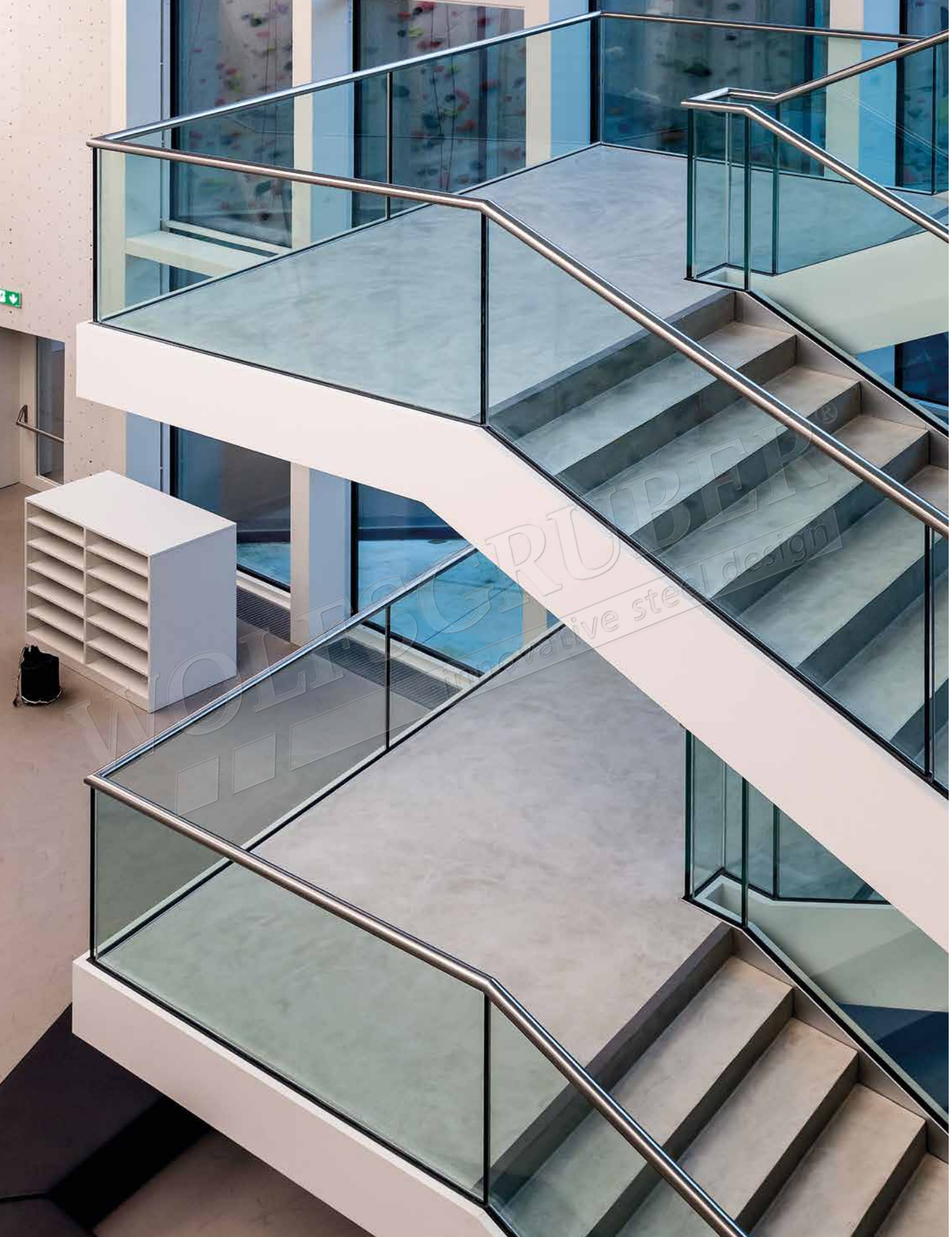

# simply glass

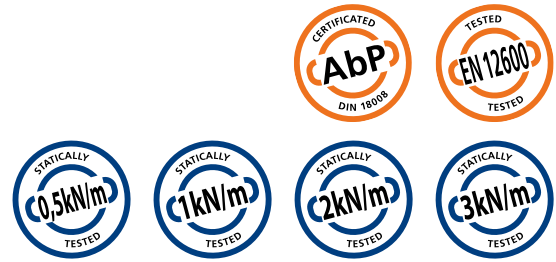

## SICURO

**it** | Massima trasparenza e un altissimo livello di sicurezza sono le caratteristiche principali del sistema SIMPLY GLASS. Un sistema completo che rende agevole e veloce l'installazione.

## SICHER

**de** | Maximale Transparenz und höchste Sicherheit standen ganz oben im Lastenheft bei der Entwicklung von SIMPLY GLASS. Das Ergebnis ist ein größtenteils vorgefertigtes Produkt, das nicht nur transparent und sicher ist, es lässt sich auch einfach, schnell und unkompliziert montieren und somit Zeit und Geld sparen.

## SAFE

**en** | Maximum transparency and highest safety were goals during the development of the glass railings. The result is a widely pre-fabricated product which is safe and transparent. It is also fast and easy to assemble, therefore saves you time and money.

## SÛR

**fr** | Une transparence maximale et haut niveau de sécurité figuraient au sommet des priorités au moment de la conception du modèle SIMPLY GLASS. Il en résulte un produit non seulement transparent et sûr, mais en grande partie préfabriqué, pour une pose simple et rapide qui fait économiser du temps et de l'argent.







# glass solutions



## PUNTUALE

**it** | Oltre alle ringhiere in solo vetro esistono diverse altre possibilità per fissare i vetri come i morsetti, fissaggi a punto, fissaggi a pavimento. Se cercate una soluzione d'impatto, o l'elegante minimalismo, per ogni esigenza architettonica offriamo la soluzione ideale.

## PUNKTUELL

**de** | Neben den Ganzglasgeländern bieten sich etliche Möglichkeiten an alternativen Glasbefestigungen wie Glasklemmen, Punkthaltern und Bodenankern. Ob Hingucker oder elegante Zurückhaltung: für jeden architektonischen Anspruch findet sich so eine individuelle Lösung.

## PUNCTUAL

**en** | In addition to all-glass balustrades there are alternative opportunities for fixations such as glass clamps, point holder and floor anchors. If eye-catcher or elegant simplicity - there are individual solutions for every architectural style.

## PONCTUEL

**fr** | Outre les garde-corps entièrement en verre, il existe bien d'autres alternatives de fixation comme les pinces à verre, les fixations ponctuelles ou au sol. Qu'il s'agisse de créer un design d'impact ou de minimalisme élégant, une solution pour toute exigence architecturale est possible.



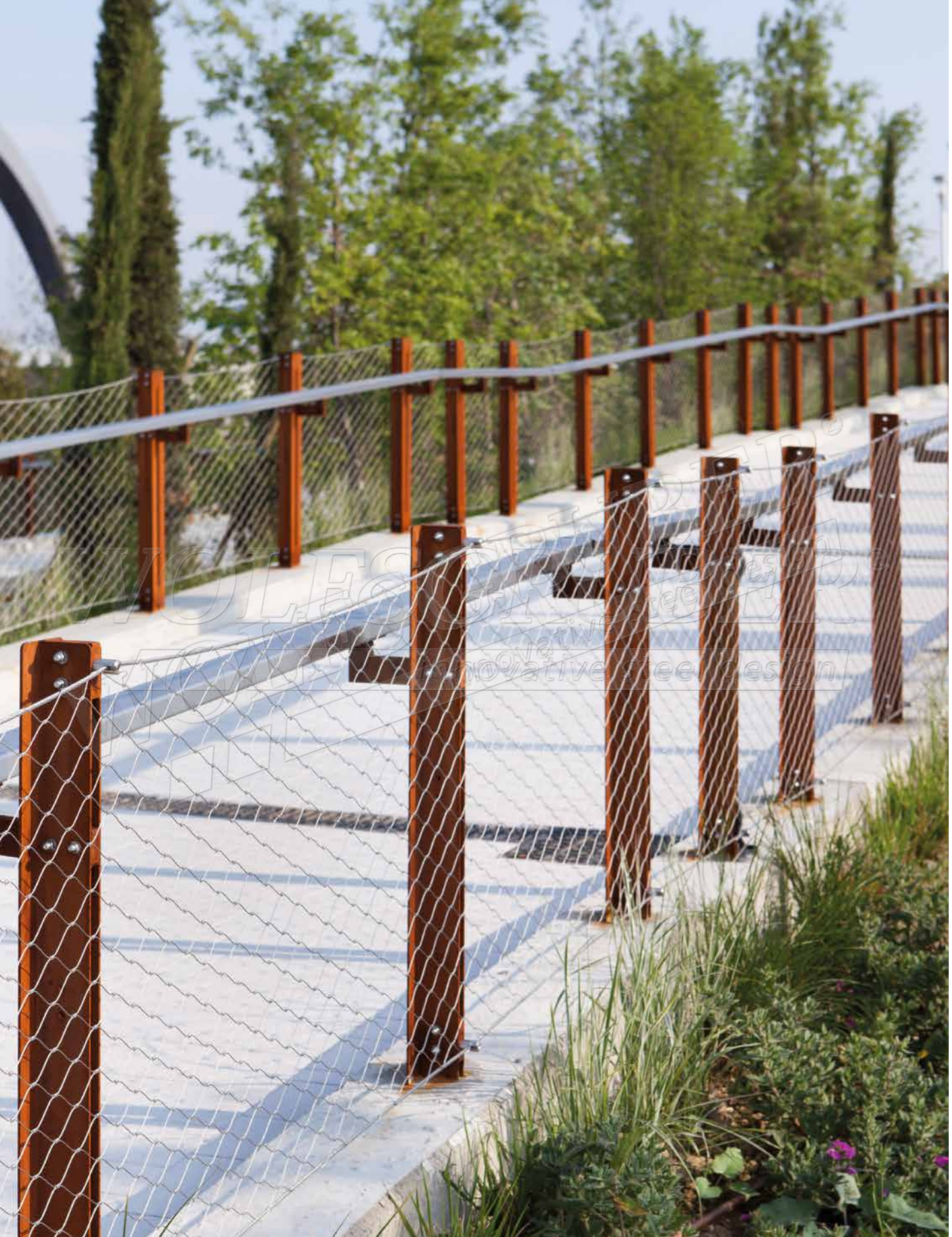

# x-tend rope

## LEGGEREZZA

**it** | Rete in filo d'acciaio X-TEND:  
Anche nell'impiego all'esterno stupiscono le sue caratteristiche: versatile nel tipo d'impiego, nelle soluzioni di ancoraggio e nelle tipologie di bordatura si può apprezzare anche l'elasticità della rete. Praticamente infinite le possibilità che si offrono in termini di forma e configurazione delle reti fissate su fune perimetrale.

## LEICHTIGKEIT

**de** | Das Edelstahlseilnetz X-TEND:  
Gerade im Außenbereich punkten seine herausragenden Eigenschaften: neben dem hohen Variantenreichtum an Maschenweiten, Befestigungsarten und Randlösungen, wird auch die Elastizität des Netzes geschätzt. Beinahe grenzenlos sind die Möglichkeiten, die sich durch die Befestigung auf Randseilen für die Formgebung eröffnen.

## LIGHTNESS

**en** | Stainless steel netting X-TEND:  
Especially in outdoor areas it convinces with its outstanding characteristics. Besides a rich variety of flexible openings of meshes, mounting methods and corner solutions the materials' flexibility is highly appreciated. There are almost unlimited design solutions which are possible by mounting nets on free-form edge ropes.

## LÉGÈRETÉ

**fr** | Filet en inox X-TEND:  
C'est tout particulièrement en extérieur que l'on peut apprécier ses caractéristiques exceptionnelles : son élasticité mais aussi la grande variété de largeurs de mailles, de types de fixation et de solutions d'encadrement. Les possibilités en termes de forme et configuration des filets fixés sur câble périmétrique sont quasiment illimitées.





# x-tend frame

## TRASPARENZA

**it** | La rete in filo d'acciaio X-TEND montata su telai si presta per svariate applicazioni architettoniche. Grazie ai diversi diametri di filo e la maglia di grandezza variabile si adatta perfettamente per progetti su misura come i numerosi cantieri realizzati all' EXPO MILANO 2015.

## TRANSPARENZ

**de** | Das Edelstahlseilnetz X-TEND auf Rahmen gespannt, eignet sich für zahllose architektonische Anwendungen. Dank der verschiedenen verfügbaren Seildurchmesser und der variablen Maschenweite des Netzes eignet sich das Element bestens für maßgeschneiderte Projekte wie die der EXPO MILANO 2015.

## TRANSPARENCY

**en** | Our stainless steel netting X-TEND strung up on frames is suitable for innumerable architectural applications. Due to the various thicknesses of the rope and the flexible openings of the meshes X-TEND frame work perfectly well for innovative and tailor-made projects such as the EXPO MILANO 2015.

## TRANSPARENCE

**fr** | Le filet inox X-TEND posé sur cadre se prête à de nombreuses applications architecturales. Grâce aux différents diamètres et largeurs de mailles possibles, il s'adapte parfaitement aux projets sur mesure comme l'EXPO 2015 à Milan.





# wrought iron

**it|** Il nostro processo continuo di modernizzazione e innovazione non trascura la vocazione artigianale. L'abilità e la creatività dei nostri collaboratori conferiscono al ferro forma e design. Wolfsgruber non conosce la parola „impossibile“: ha tutti gli strumenti per soddisfare i vostri desideri e per realizzare con successo le Vostre idee.

**de|** Bei aller Modernisierung und Innovation werden handwerkliche Traditionen nie vernachlässigt. Durch Geschicklichkeit, Kreativität der erfahrenen Mitarbeiter wird dem Eisen Form und Ästhetik gegeben. Das Wort „unmöglich“ kennt man in der Firma Wolfsgruber nicht. Dank dem eigenen Werkzeugbau ist es möglich speziellen Kundenwünschen nachzukommen und auch ihre Idee zu einem erfolgreichen Abschluss zu bringen.

**en|** Modernisation and innovation are never at the expense of traditional expertise. The skill and creativity of our experienced workforce give form and aesthetic qualities to the iron. The word „impossible“ is not one we recognise in the Wolfsgruber company. By constructing our own tools, we can satisfy special customer requests and ensure their successful conclusion.

**fr|** Notre procès continu de modernisation et d'innovation n'oublie pas la vocation artisanale. Le savoir faire et la créativité de nos collaborateurs donnent au fer forme et design. Rien n'est impossible pour Wolfsgruber: nous avons tous les instruments pour répondre à vos désirs et pour réaliser vos idées avec succès.



# BASIC

accessori | Zubehör | accessories | accessoires

AISI 304 - V2A - 1.4301

- 1) M01551240
- 2) M01851240
- 3) 62326 (Ø42,4x2,0)



- 4) 62125 (Ø42,4x2,0)



- 5) 63391 (Ø12,0x1,5)



- 6) 20751 (Ø42,4x2,0)



- 7) 20725 (Ø12,0x1,5)



- 8) 61255 (Ø42,4x2,0)



- 9) 64087 (Ø 12,3)

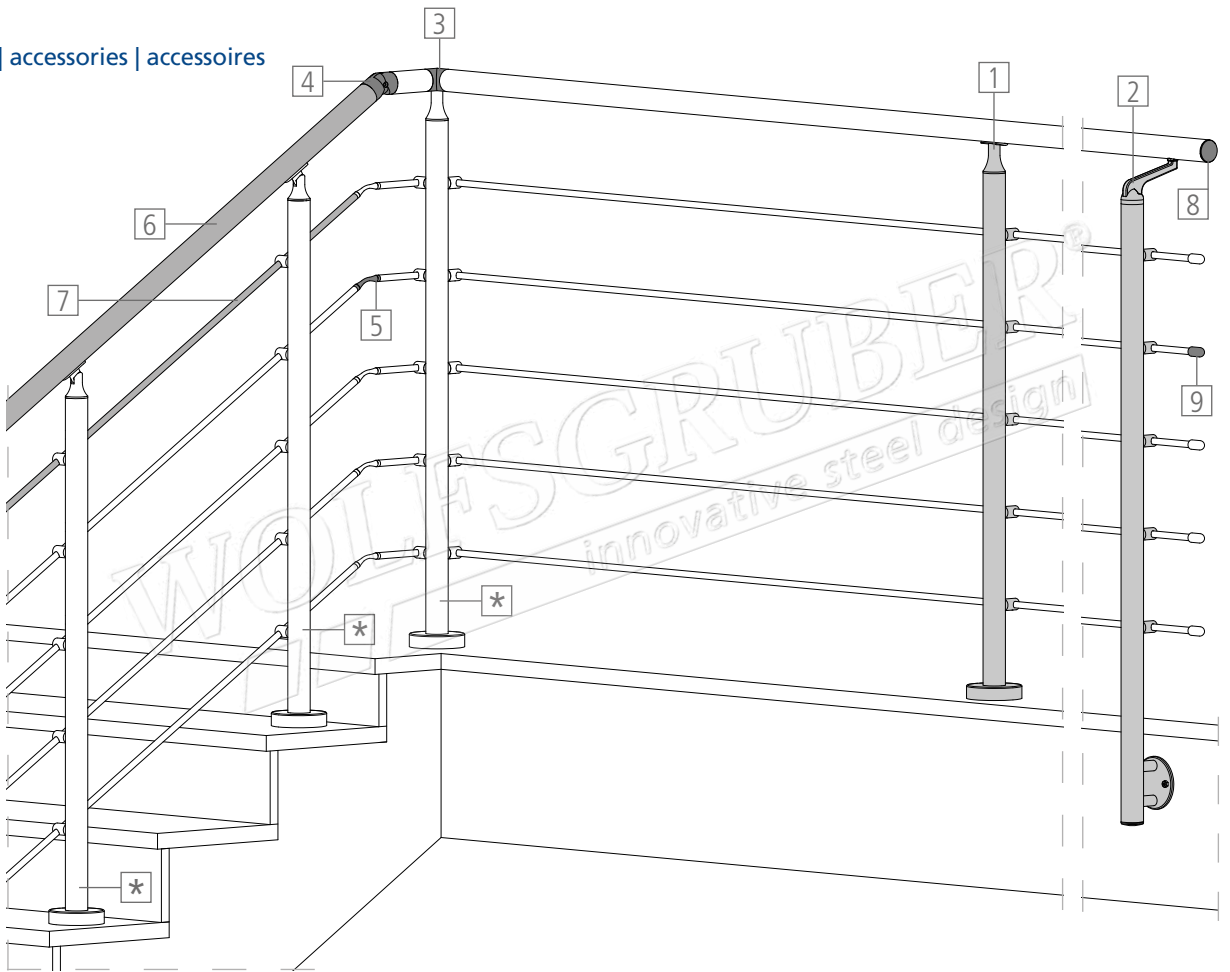

# BASIC GLASS

accessori | Zubehör | accessories | accessoires

AISI 304 - V2A - 1.4301

- 1) M065000C40
- 2) M068000C40
- 3) 62325 (Ø42,4x2,0)



- 4) 62125 (Ø42,4x2,0)



- 5) 20751 (Ø42,4x2,0)

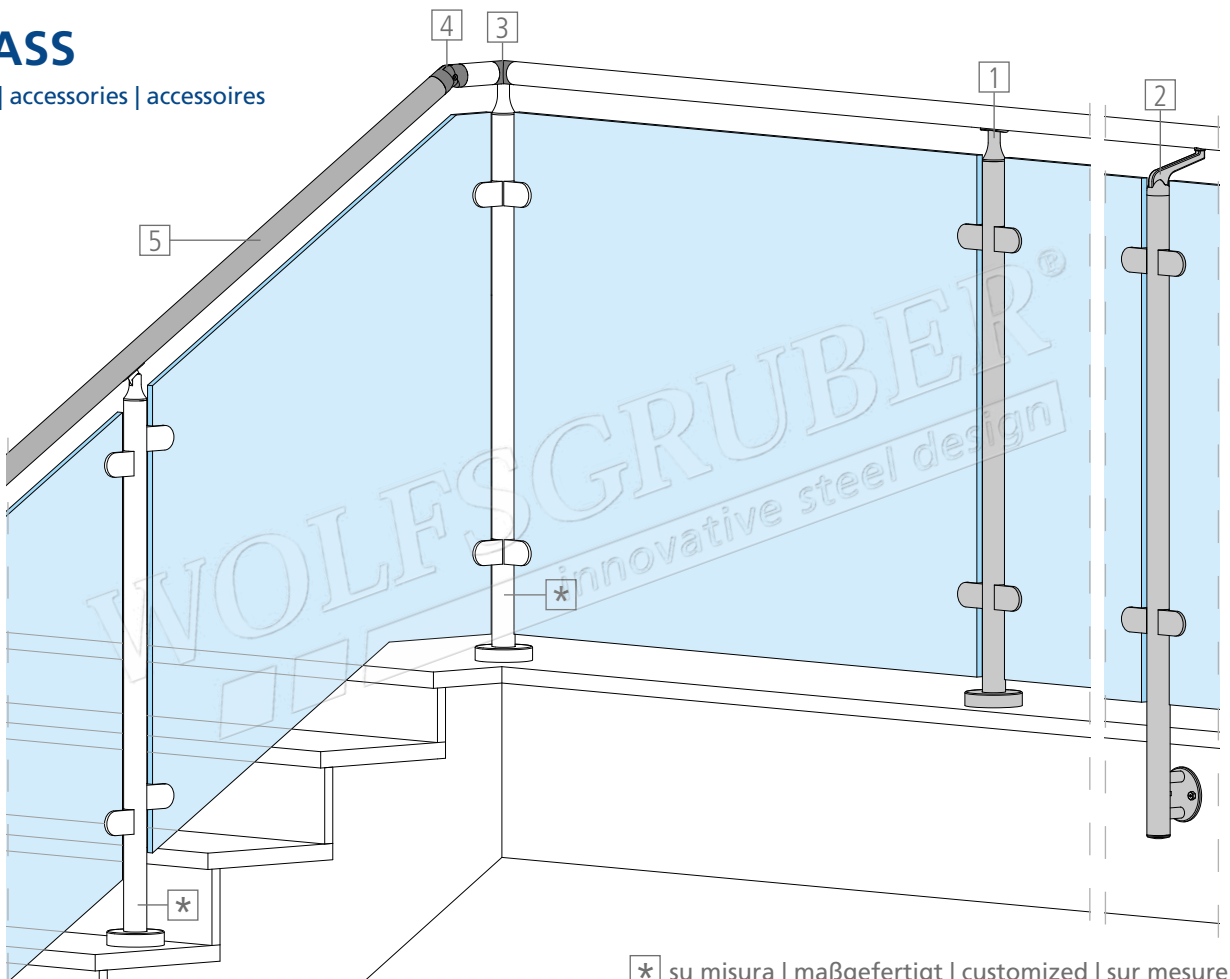

\* su misura | maßgefertigt | customized | sur mesure



# BASIC GLASS PLUS

accessori | Zubehör | accessories | accessoires

AISI 304 - V2A - 1.4301

- 1) M071312C40
- 2) M073312C40
- 3) 62325 (Ø42,4x2,0)



- 4) 62316 (Ø42,4x2,0)



- 5) 63392 (Ø12,0x1,5)



- 6) 20751 (Ø42,4x2,0)



- 7) 20725 (Ø12,0x1,5)

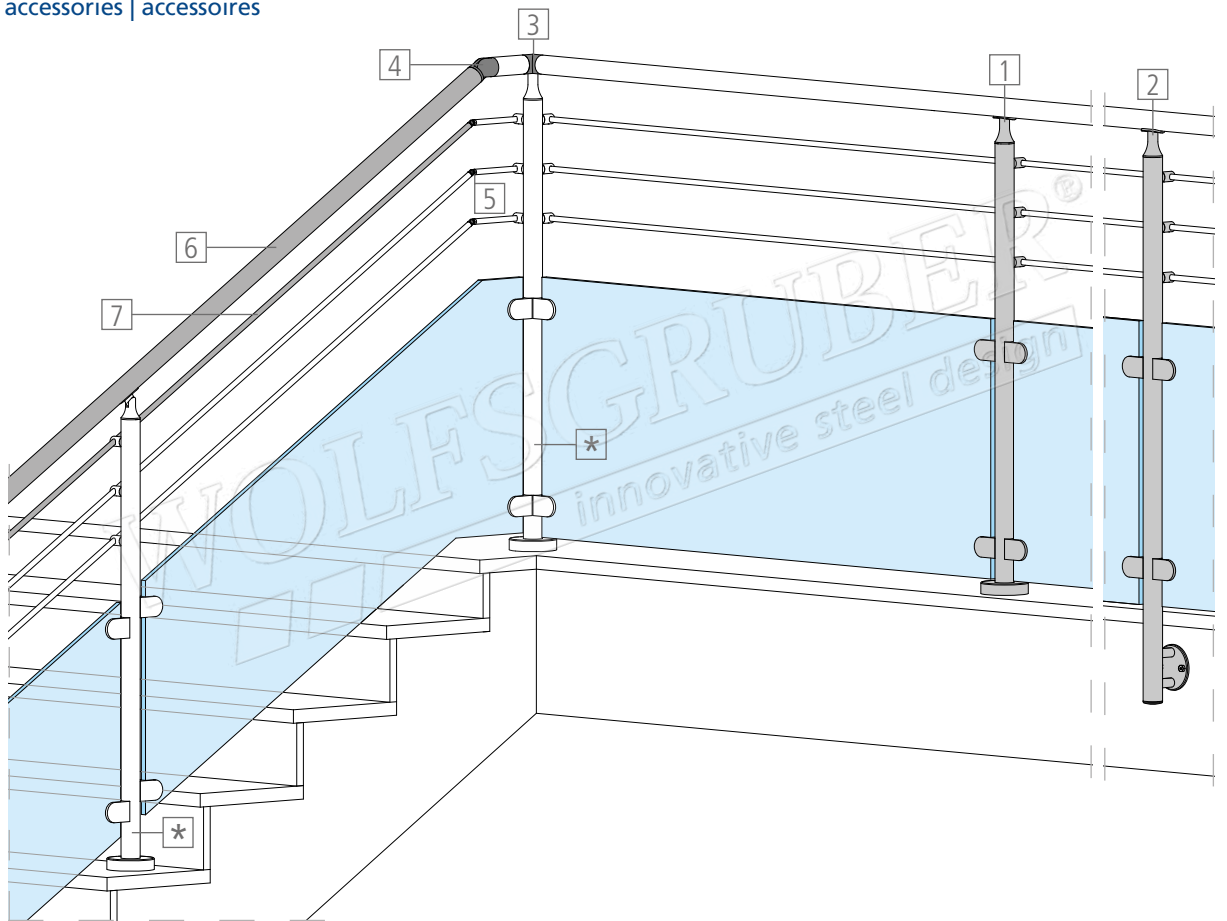

# BASIC IN AXIS

accessori | Zubehör | accessories | accessoires

AISI 304 - V2A - 1.4301

- 1) M03551240
- 2) M03751240
- 3) 62326 (Ø42,4x2,0)



- 4) 62135 (Ø42,4x2,0)



- 5) 63332 (Ø12,3)



- 6) 20751 (Ø42,4x2,0)



- 7) 20653 (Ø12,0x1,5)



- 8) 61006 (Ø42,4x55)



- 9) 64012 (Ø12,3)

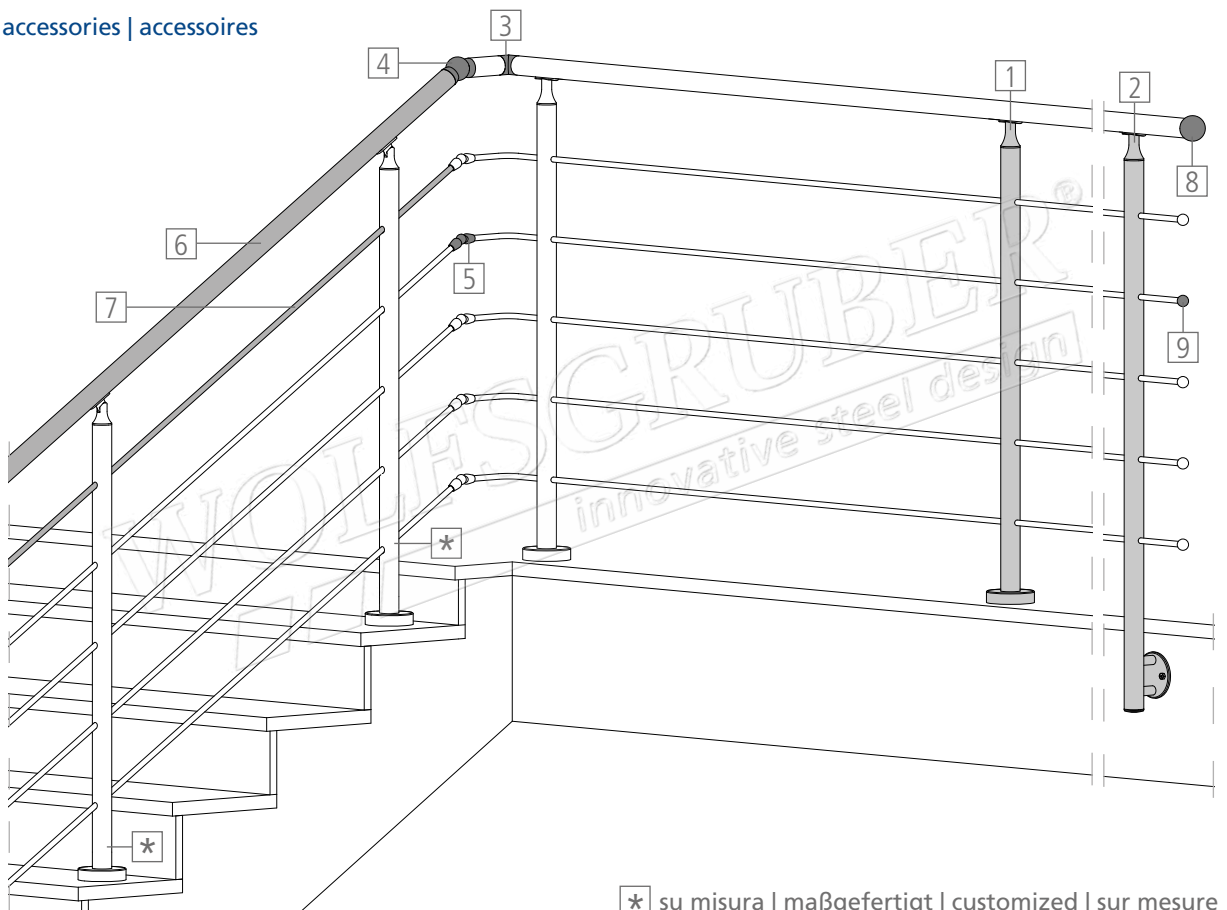

\* su misura | maßgefertigt | customized | sur mesure

# QUADRO

accessori | Zubehör | accessories | accessoires

AISI 304 - V2A - 1.4301

1) M12551340

2) M12751340

3) 62681-V4A (40x40x2,0)



4) 62682-V4A (40x40x2,0)



5) 63393-V4A (12x12x1,5)



6) 20680 (40x40x2,0)



7) 20672 (12x12x1,5)



8) 61438 (40x40x2,0)



9) 64020-V4A (12)

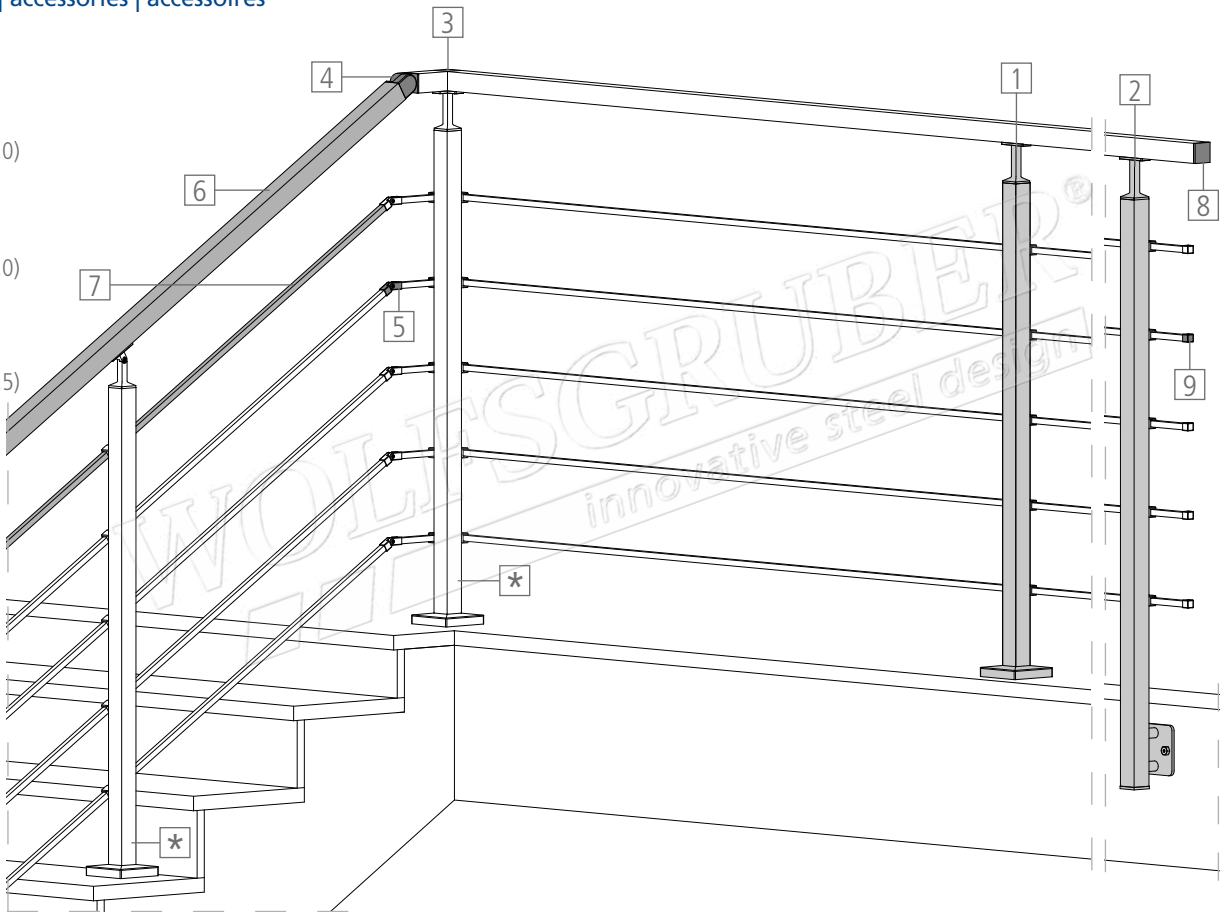

# QUADRO GLASS

accessori | Zubehör | accessories | accessoires

AISI 304 - V2A - 1.4301

1) M165000C40

2) M167000C40

3) 62681-V4A (40x40x2,0)



4) 62682-V4A (40x40x2,0)



5) 20680 (40x40x2,0)

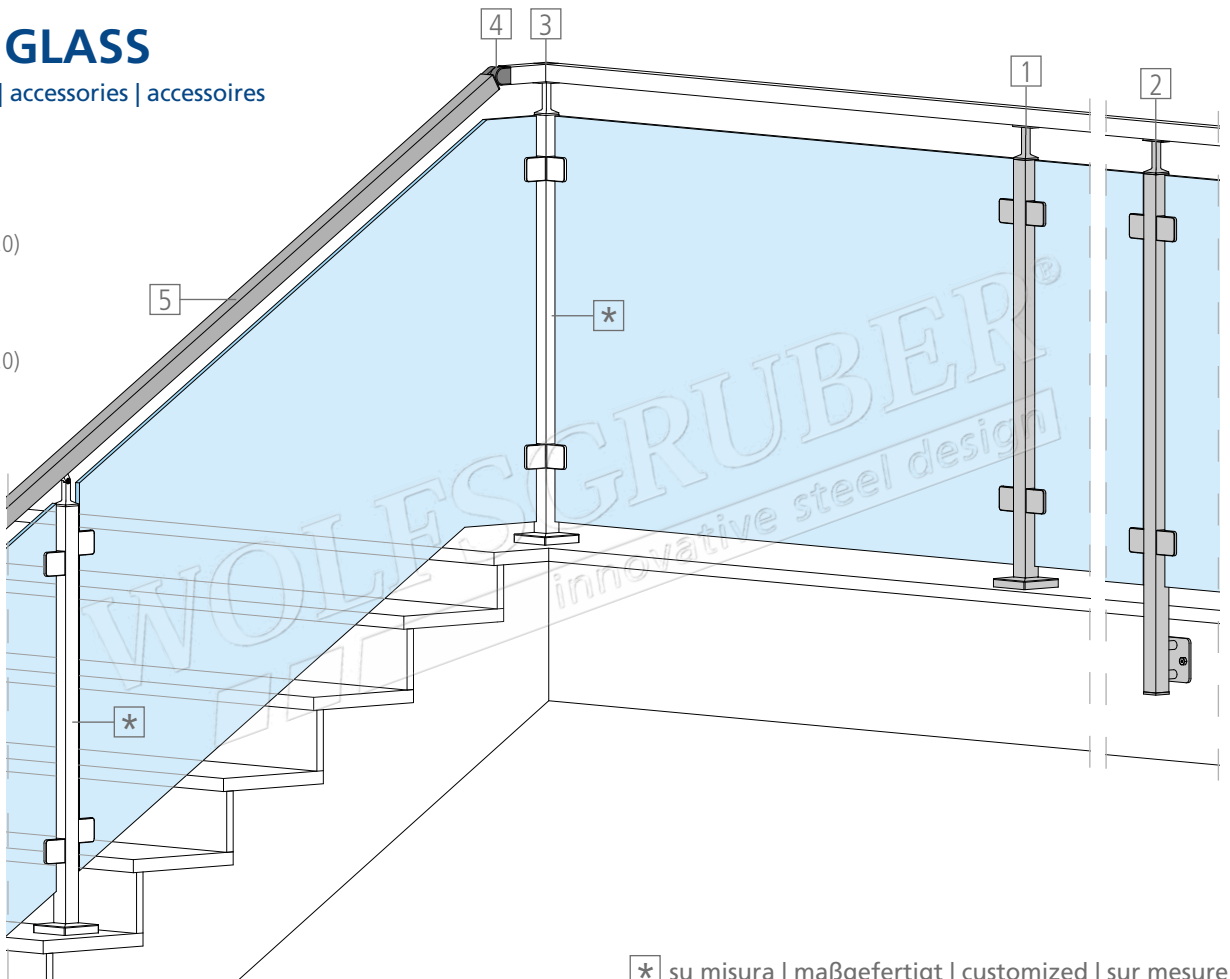

\* su misura | maßgefertigt | customized | sur mesure

# TWIN

accessori | Zubehör | accessories | accessoires

AISI 304 - V2A - 1.4301

- 1) M22551240
- 2) M22851240
- 3) 62326 (Ø42,4x2,0)



- 4) 62316 (Ø42,4x2,0)



- 5) 63397 (Ø12,3)



- 6) 20751 (Ø42,4x2,0)



- 7) 20725 (Ø12,0x1,5)



- 8) 61255 (Ø42,4x2,0)



- 9) 64038 (Ø12,3)

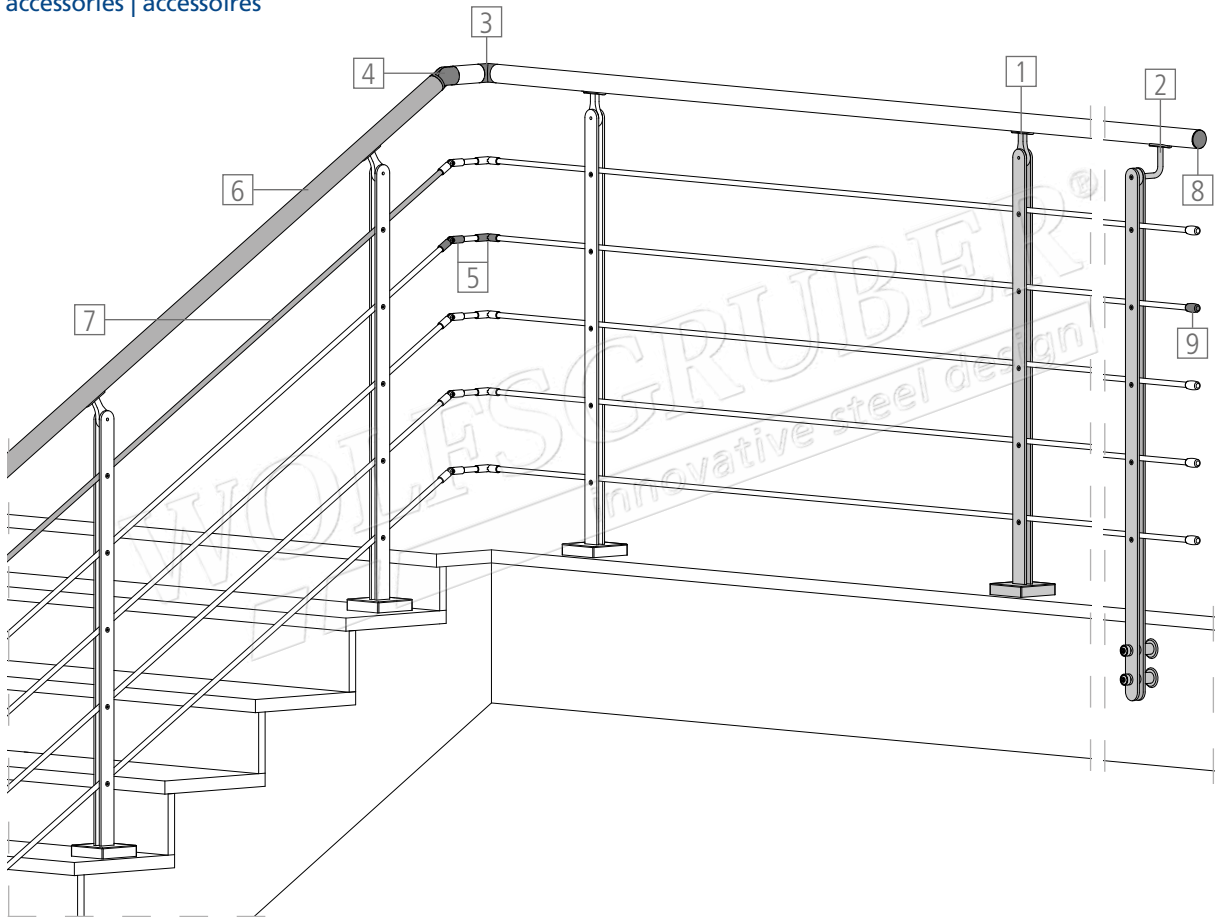

# TWIN PLUS

accessori | Zubehör | accessories | accessoires

AISI 304 - V2A - 1.4301

- 1) M32551240
- 2) M32851240
- 3) 62326 (Ø42,4x2,0)



- 4) 62316 (Ø42,4x2,0)



- 5) 63392 (Ø12,0x1,5)



- 6) 20751 (Ø42,4x2,0)



- 7) 20725 (Ø12,0x1,5)



- 8) 61095 (Ø42,4x2,0)



- 9) 64083 (Ø12,3)

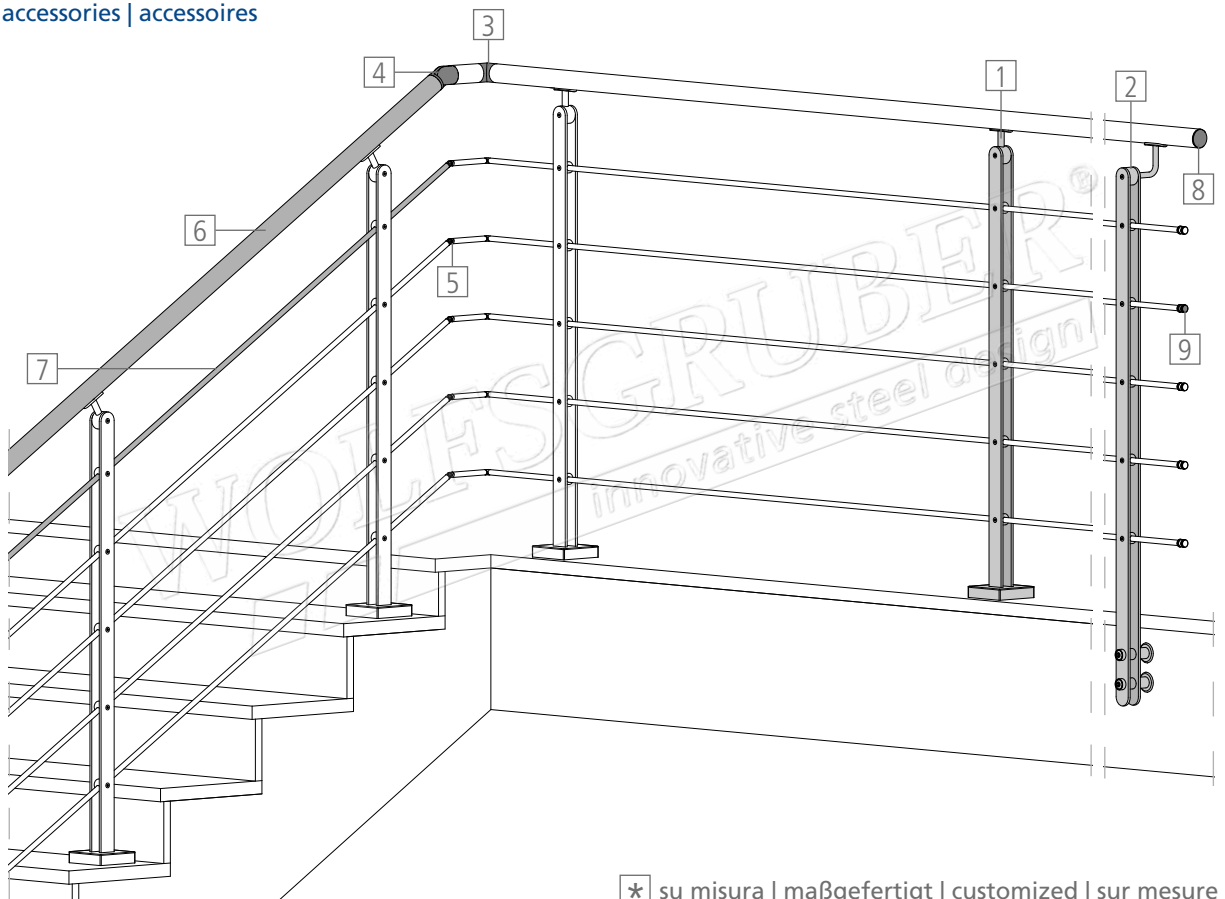

\* su misura | maßgefertigt | customized | sur mesure

# INOX STEP SYSTEM

accessori | Zubehör | accessories | accessoires

AISI 304 - V2A - 1.4301

- 1) M201040
- 2) M241140
- 3) 62125 (Ø42,4x2,0)



- 4) 63395 (Ø12,2)



- 5) 20751 (Ø42,4x2,0)



- 6) 20653 (Ø12,0)



- 7) 61006 (Ø42,4x55)



- 8) 64032 (Ø12,3)



- 9) 62812 (Ø12)

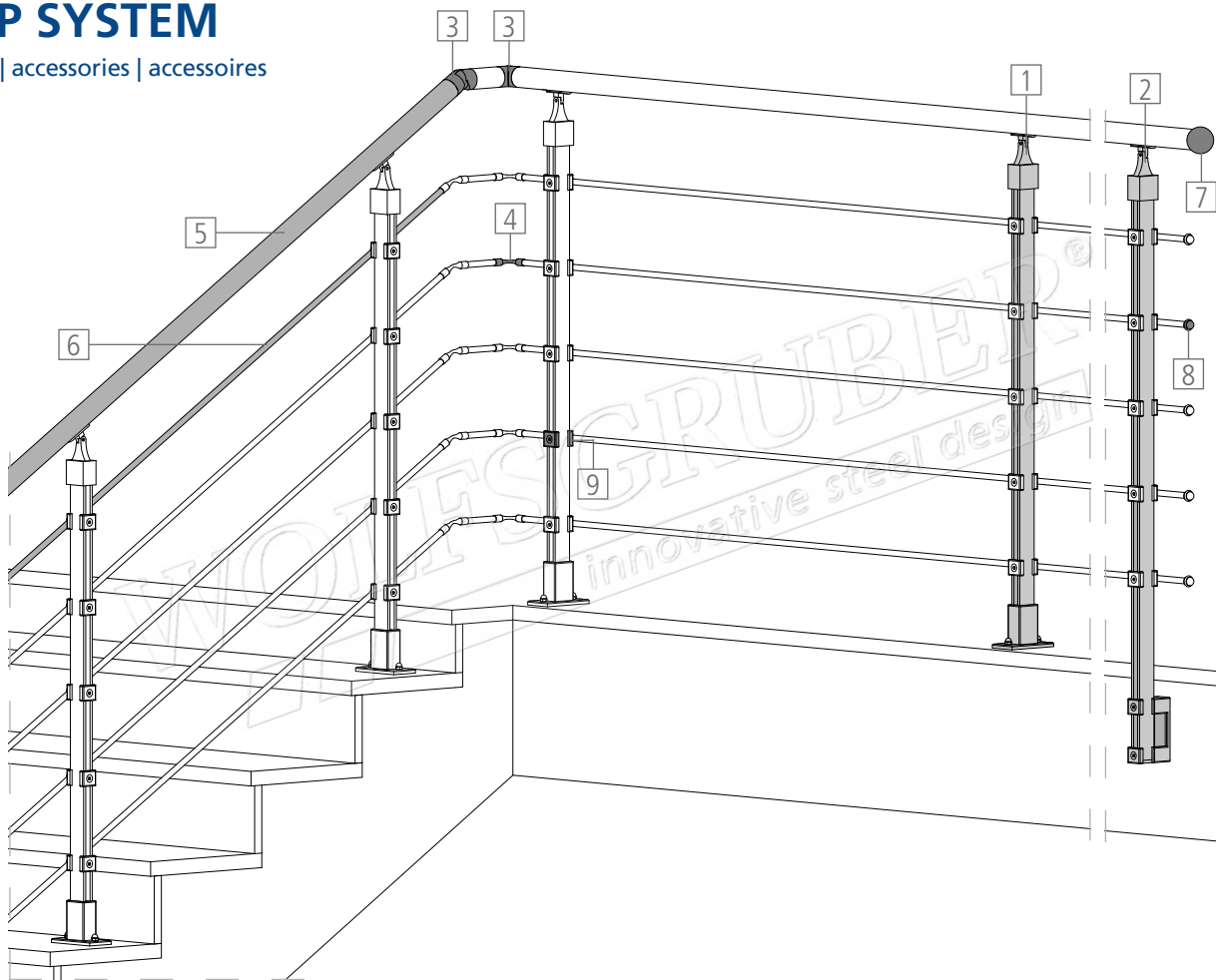

# INOX STEP SYSTEM GLASS

accessori | Zubehör | accessories | accessoires

AISI 304 - V2A - 1.4301

- 1) M201040
- 2) M251140
- 3) 62125 (Ø42,4x2,0)



- 4) 20751 (Ø42,4x2,0)



- 5) 62841 (8,00-12,76)



- 6) 62840 (8,00-12,76)

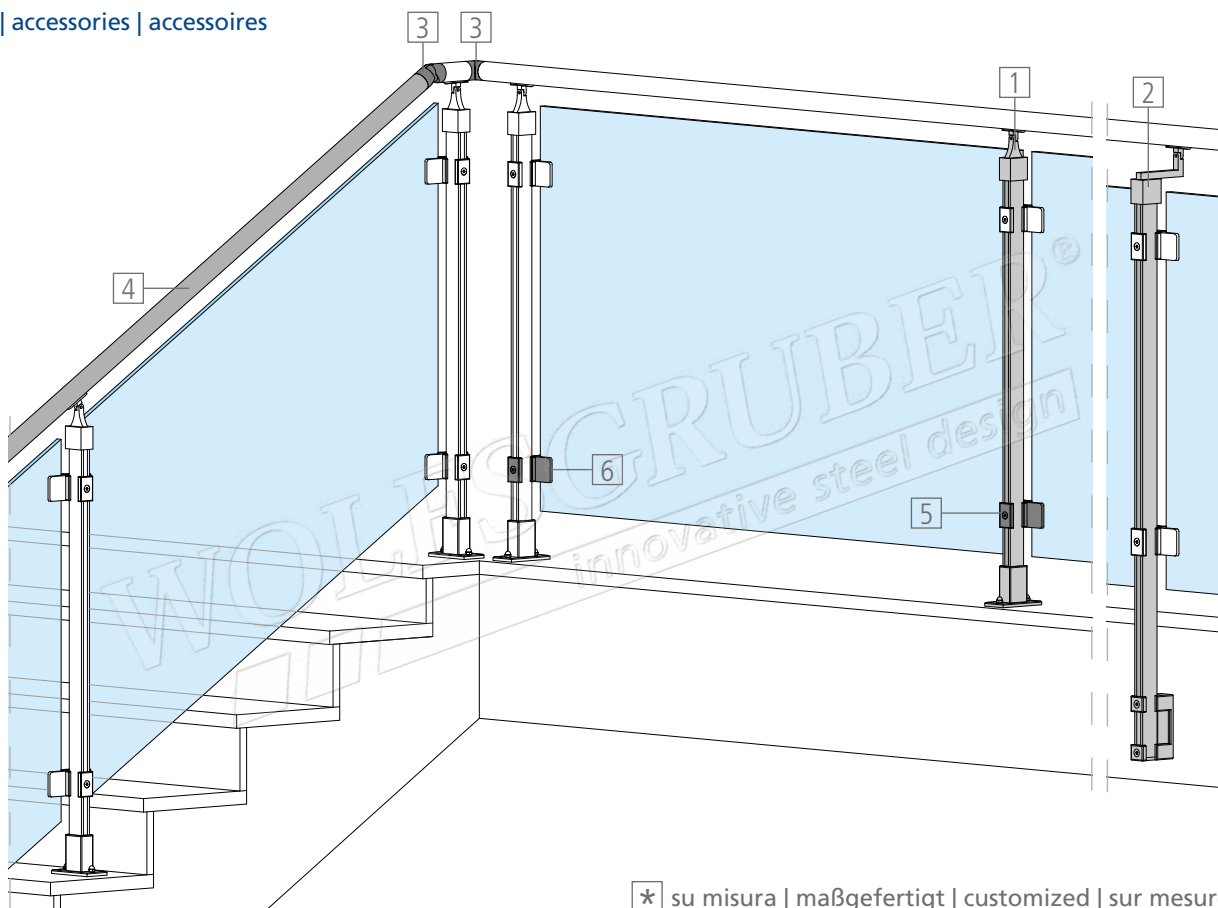

\* su misura | maßgefertigt | customized | sur mesure

# ALU STEP SYSTEM

accessori | Zubehör | accessories | accessoires

AISI 304 - V2A - 1.4301

- 1) 62705
- 2) 62720
- 3) 62326 (Ø42,4x2,0)

- 4) 62316 (Ø42,4x2,0)
- 5) 20751 (Ø42,4x2,0)

- 6) 20622 (20x5)
- 7) 61265 (Ø42,4x2,0)

- 8) 62749 (Ø16)

- 9) 61265 (Ø42,4x2,0)

- 10) 62749 (Ø16)

- 11) 62749 (Ø16)

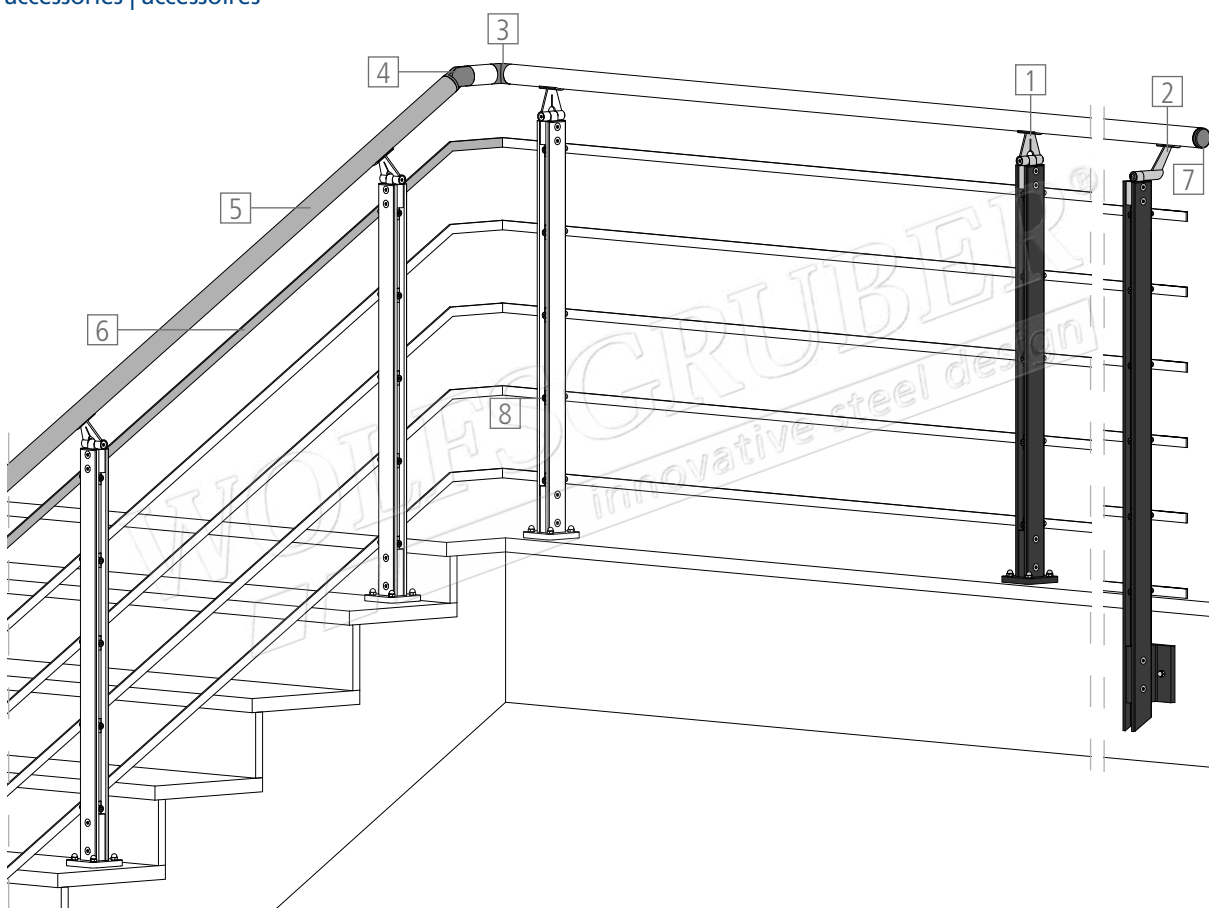

# ALU STEP SYSTEM

accessori | Zubehör | accessories | accessoires

AISI 304 - V2A - 1.4301

- 1) 62705
- 2) 62715
- 3) 62326 (Ø42,4x2,0)

- 4) 20751 (Ø42,4x2,0)
- 5) 61035 (Ø42,4x2,0)

- 6) 62751 (Ø16)
- 7) 62750 (Ø16)

- 8) 62741 (8,00-12,76)

- 9) 62741 (8,00-12,76)

- 10) 62741 (8,00-12,76)

- 11) 62741 (8,00-12,76)

- 12) RK1350506-30 (Ø5) \*

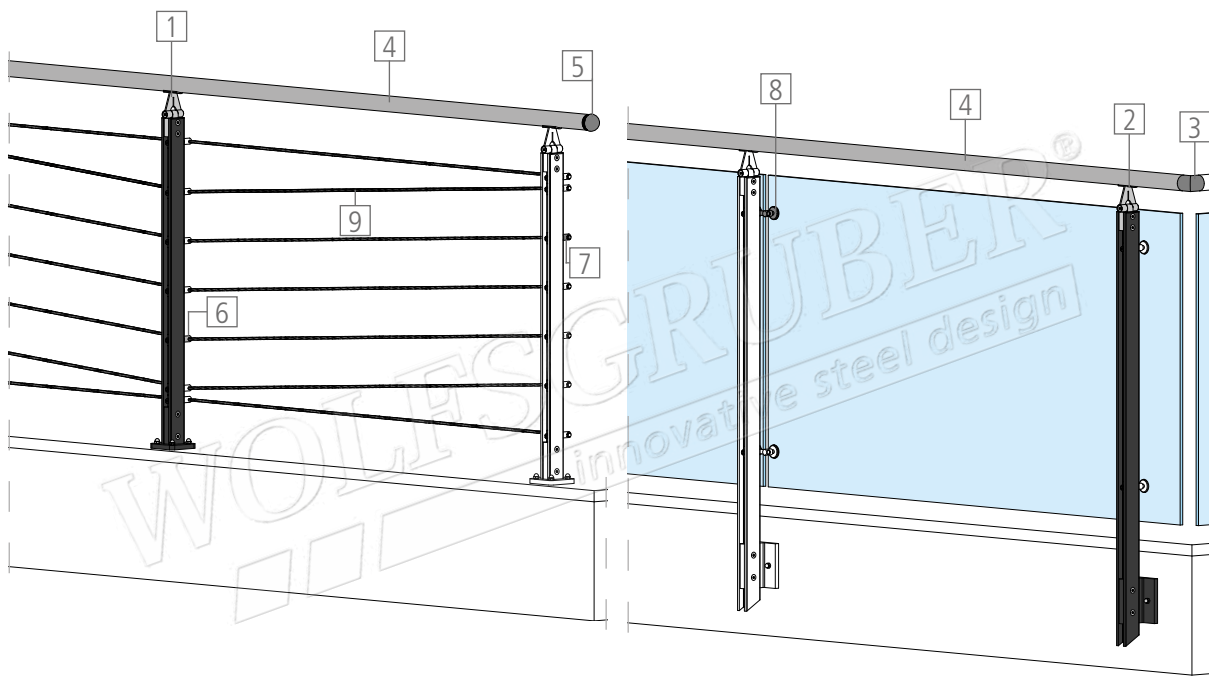

\* su misura | maßgefertigt | customized | sur mesure

# LASER

accessori | Zubehör | accessories | accessoires

AISI 304 - V2A - 1.4301

- 1) M64281240
- 2) M64381240
- 3) 62135 (Ø42,4x2,0)

- 4) 20751 (Ø42,4x2,0)

- 5) 20725 (Ø12,0x1,5)

- 6) 63391 (Ø12,0x1,5)

- 7) 63322 (Ø12,2)

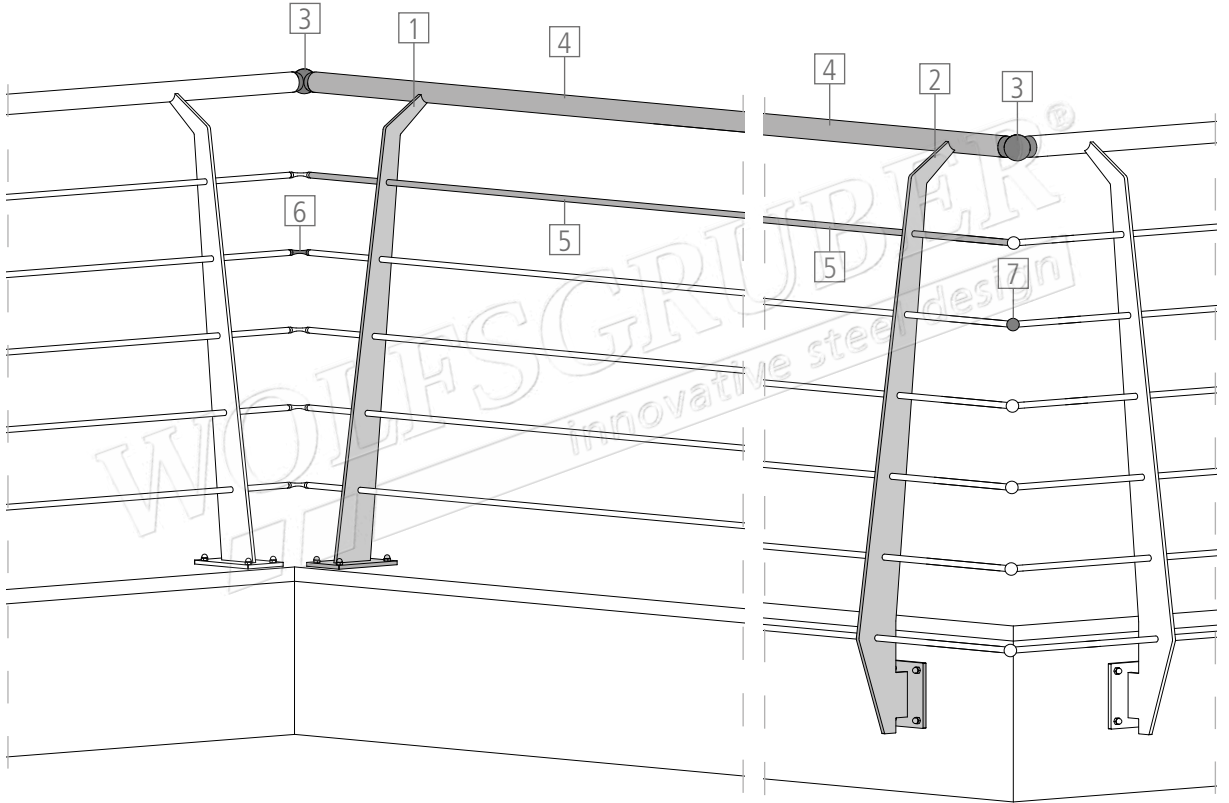

# LASER CURVE

accessori | Zubehör | accessories | accessoires

AISI 304 - V2A - 1.4301

- 1) M63351240
- 2) M63551240
- 3) 62316 (Ø42,4x2,0)

- 4) 20751 (Ø42,4x2,0)

- 5) 20725 (Ø12,0x1,5)

- 6) 63391 (Ø12,0x1,5)

- 7) 64038 (Ø 12,3)

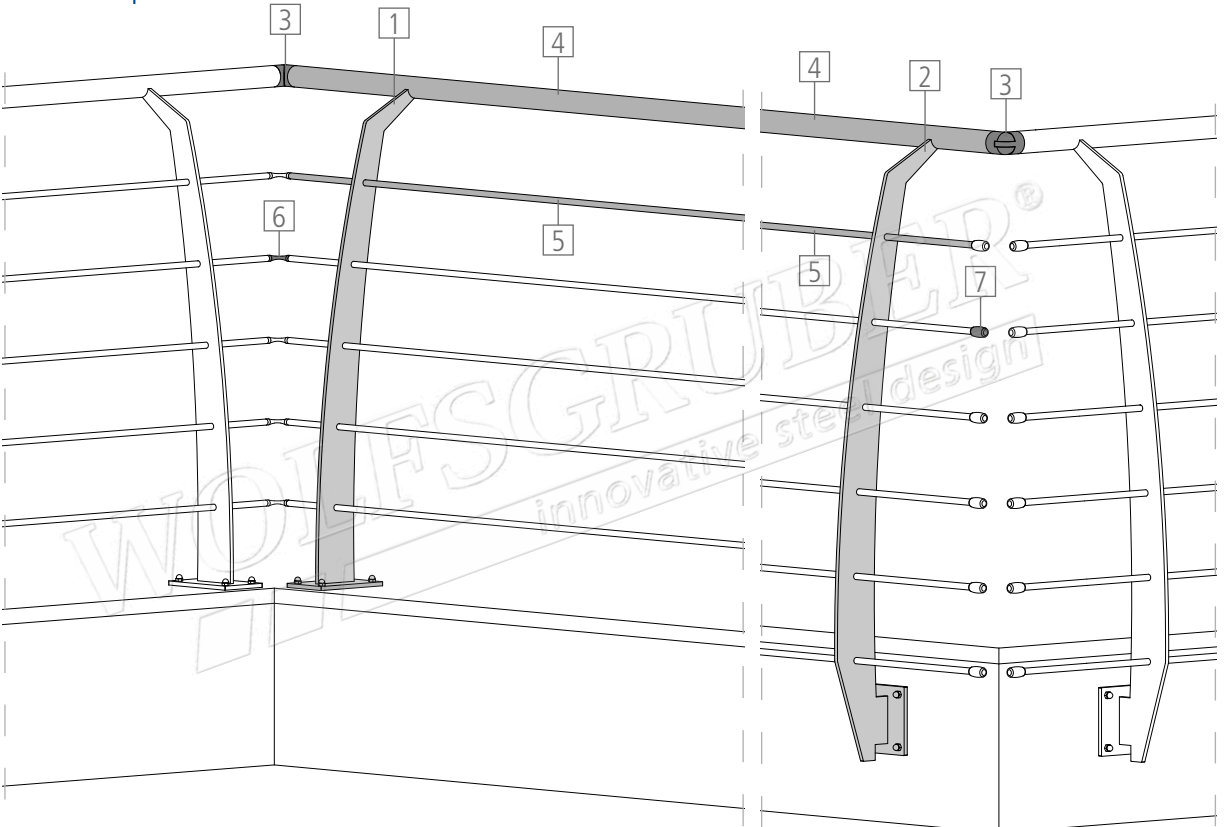

\* su misura | maßgefertigt | customized | sur mesure

# LASER GLASS

accessori | Zubehör | accessories | accessoires

AISI 304 - V2A - 1.4301

- 1) M672000C40
- 2) M674000C40
- 3) 62125 (Ø42,4x2,0)



- 4) 20751 (Ø42,4x2,0)

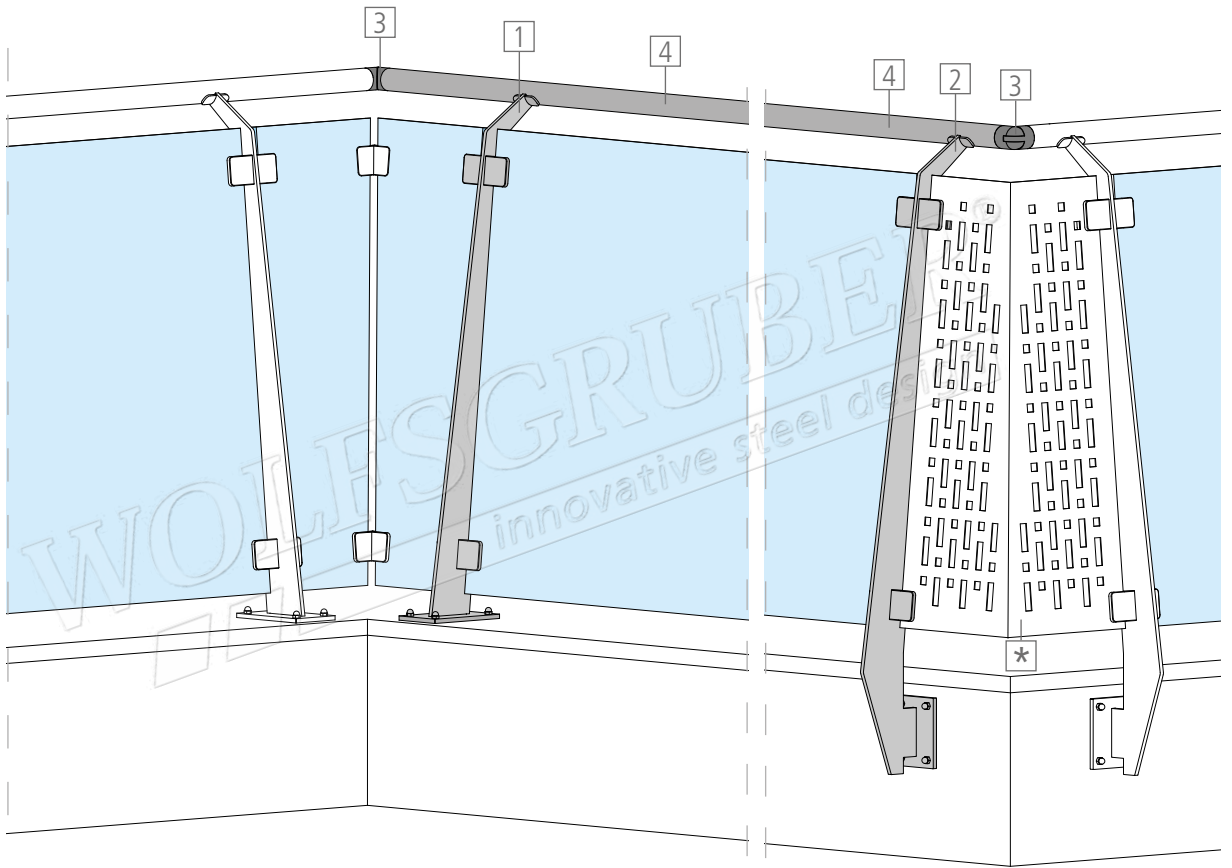

# LASER PLUS

accessori | Zubehör | accessories | accessoires

AISI 304 - V2A - 1.4301

- 1) M61251240
- 2) M61451240
- 3) 62326 (Ø42,4x2,0)



- 4) 62125 (Ø42,4x2,0)



- 5) 20751 (Ø42,4x2,0)



- 6) 20725 (Ø12,0x1,5)



- 7) 63391 (Ø12,0x1,5)



- 8) 61255 (Ø42,4x2,0)



- 9) 64085 (Ø12,3)

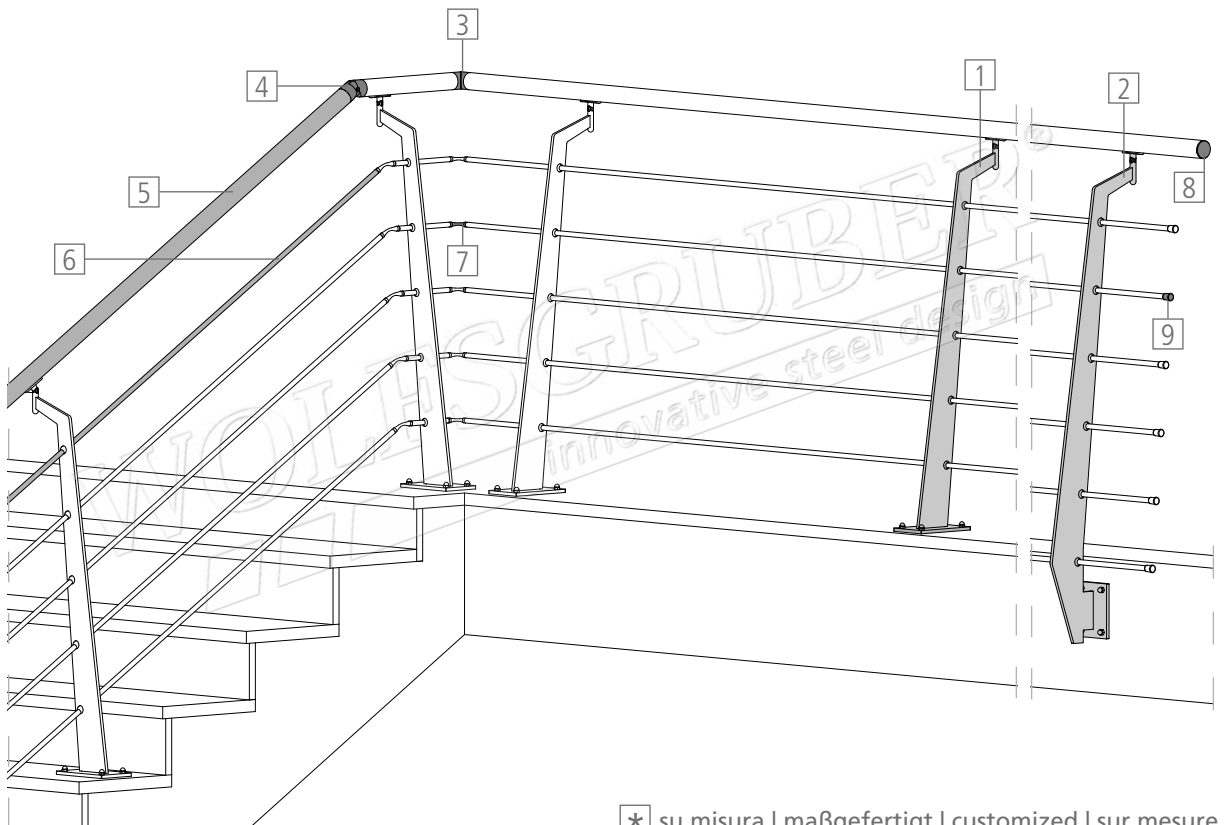

\* su misura | maßgefertigt | customized | sur mesure

# SIMPLY GLASS

accessori | Zubehör | accessories | accessoires

AISI 304 - V2A - 1.4301

1) G64333 40



2) G6011011



3) G6312010



4) G6012010



5) G6142040



6) G6013330 (21,52mm)

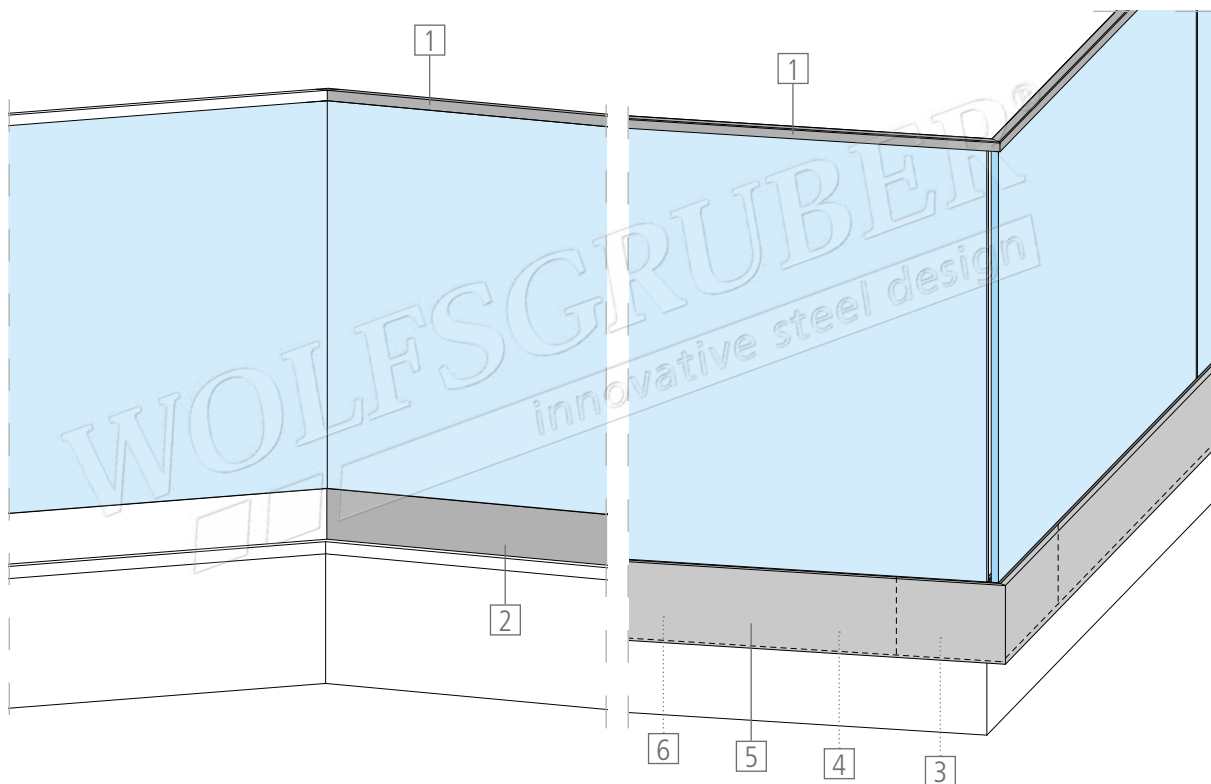

# GLASS SOLUTIONS

accessori | Zubehör | accessories | accessoires

AISI 304 - V2A - 1.4301

1) 67702 (Ø42,4x1,5)



2) 67712 (Ø42,4)



3) 67773 (21,52mm)



4) 67772 (17,52mm)



5) G0951140-40



6) MG101740

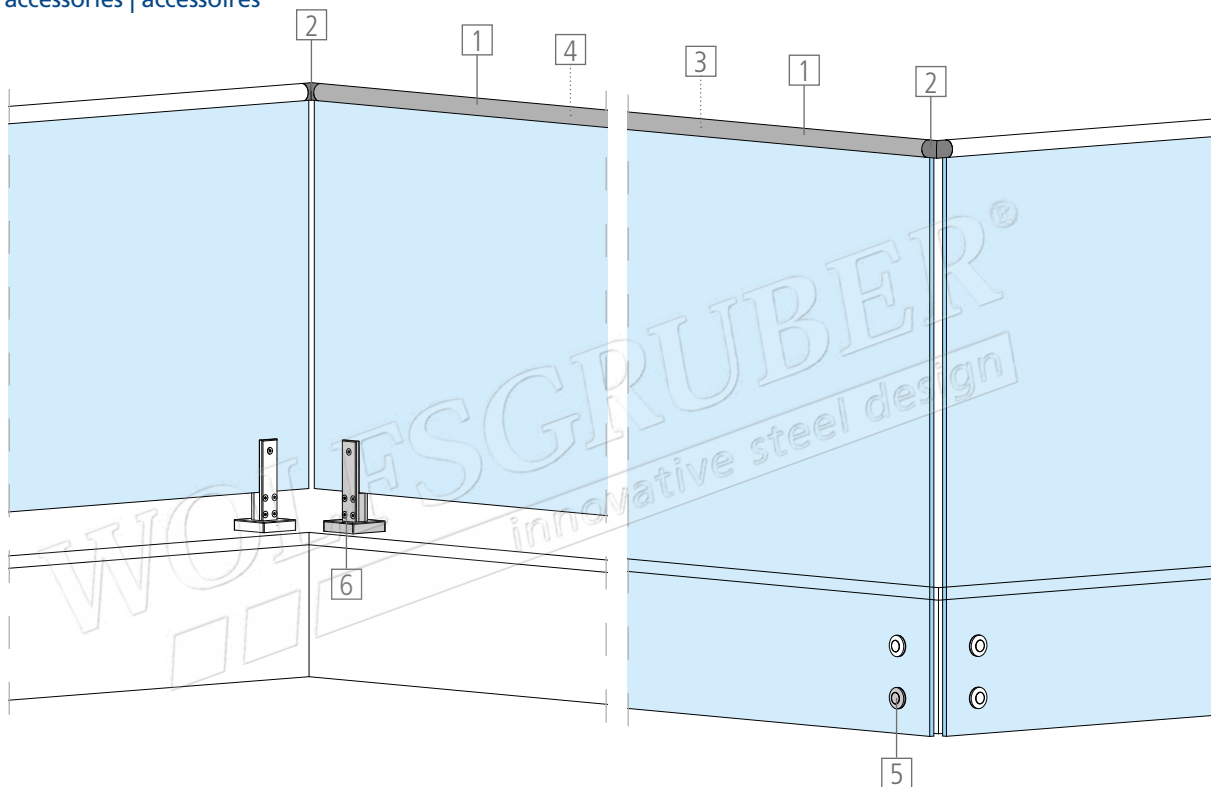

\* su misura | maßgefertigt | customized | sur mesure



# PLATE SOLUTIONS

accessori | Zubehör | accessories | accessoires

AISI 304 - V2A - 1.4301

1) 20751 (Ø42,4x2,0)



2) 62326 (Ø42,4x2,0)



3) 62316 (Ø42,4x2,0)



4) 62404



5) 62518



6) 62420



7) 62422



8) 62426

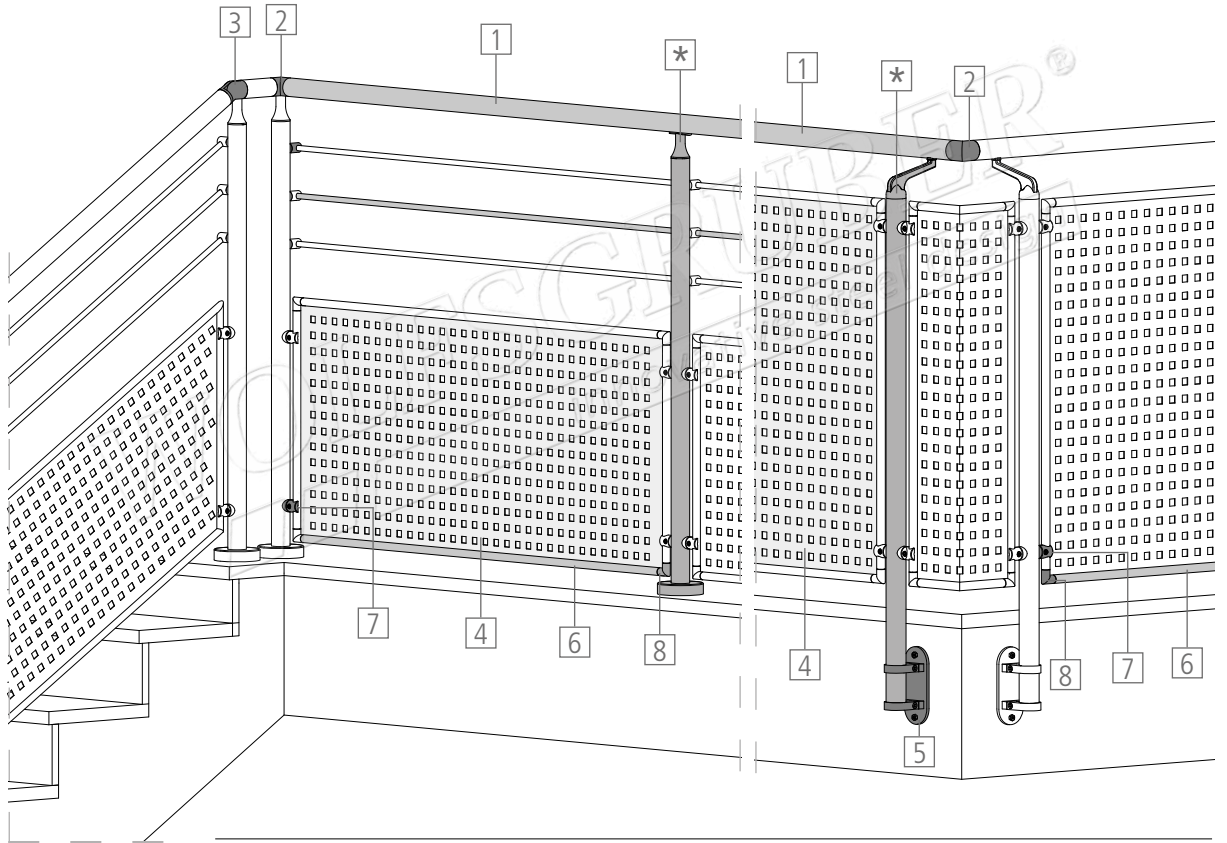

# ROPE SOLUTIONS

accessori | Zubehör | accessories | accessoires

AISI 304 - V2A - 1.4301

1) 20751 (Ø42,4x2,0)



2) 62326 (Ø42,4x2,0)



3) 62316 (Ø42,4x2,0)



4) 87906-142 (Ø6)  
-242 (Ø6)  
-342 (Ø6)



5) RK1350608-30 (Ø6)



6) 62404



7) 62422



8) 62420

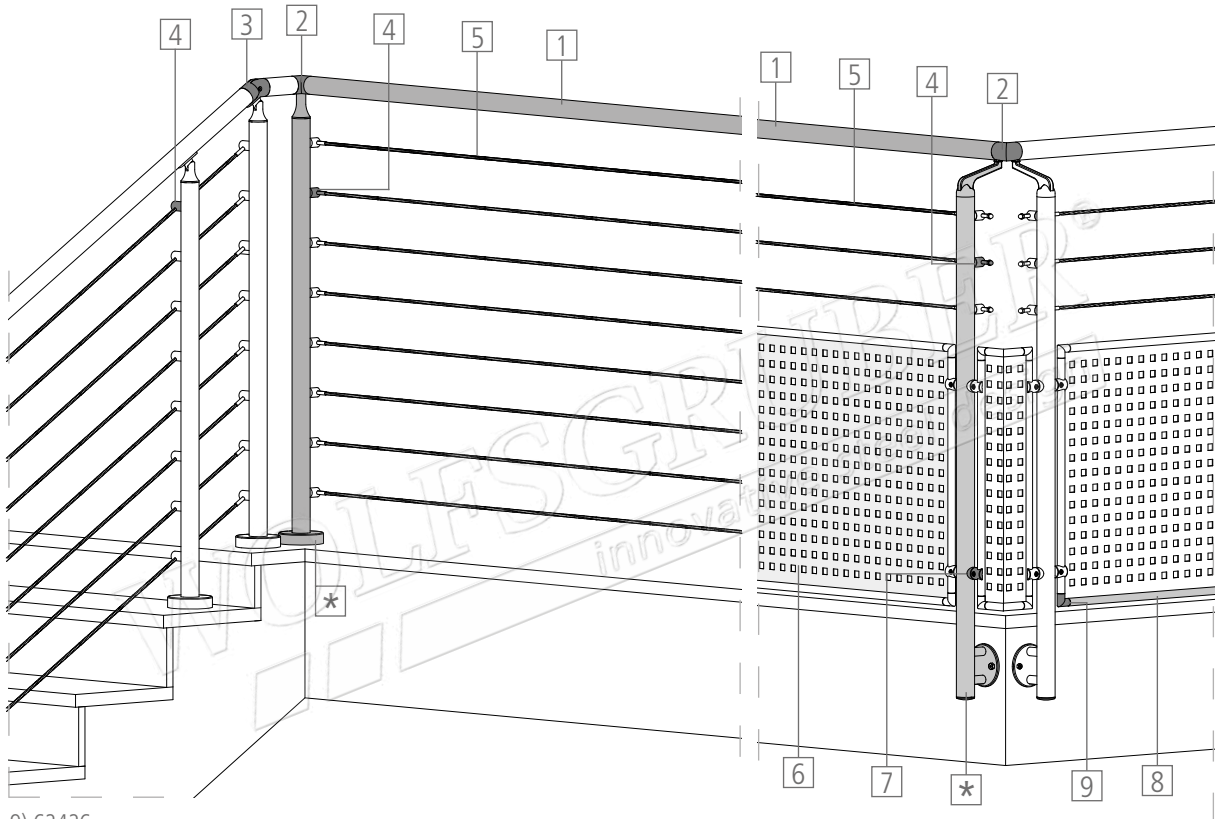

9) 62426

\* su misura | maßgefertigt | customized | sur mesure

# X-TEND ROPE

accessori | Zubehör | accessories | accessoires

AISI 304 - V2A - 1.4301

1) 20751 (Ø42,4x2,0)

2) 62326 (Ø42,4x2,0)

3) 20725 (Ø12,0x1,5)

4) 63416C

5) CX900142

6) CX900242

7) RK4180608-14

8)

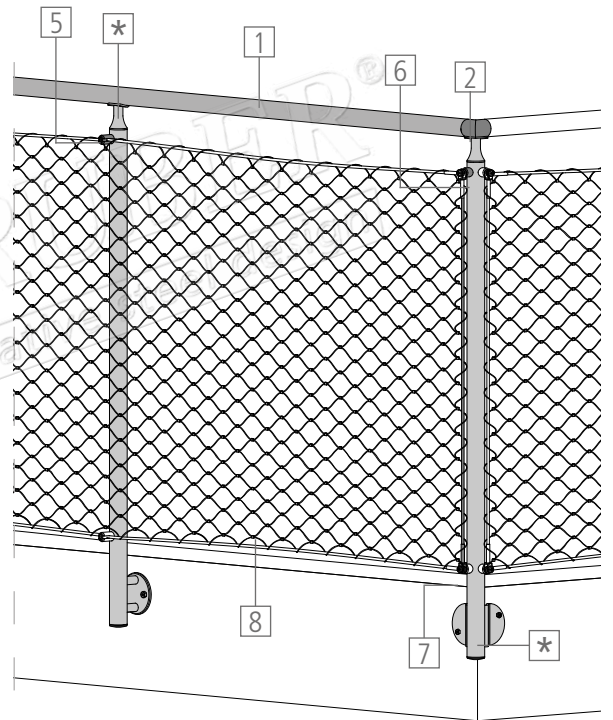
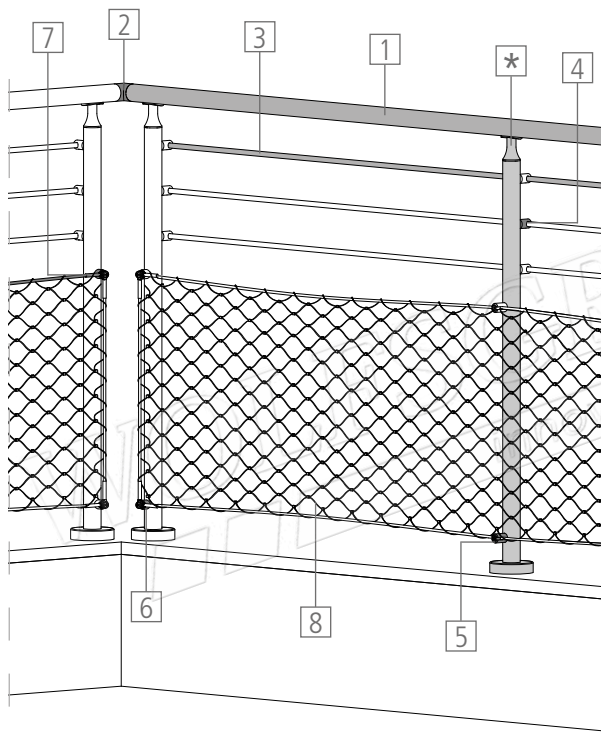

# X-TEND FRAME

accessori | Zubehör | accessories | accessoires

AISI 304 - V2A - 1.4301

1) 20751 (Ø42,4x2,0)

2) 62325 (Ø42,4x2,0)

3) 20725 (Ø12,0x1,5)

4) 63416C

5) 62432

6) 20739

7)

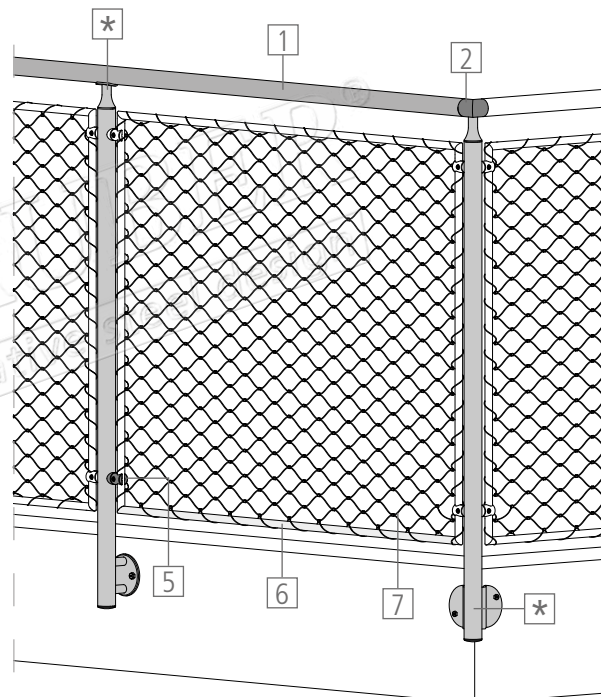
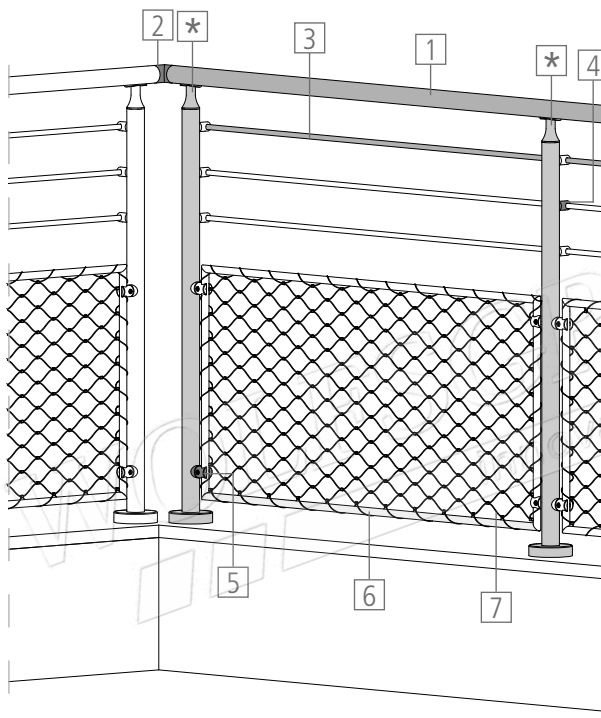

\* su misura | maßgefertigt | customized | sur mesure

## SYMBOLS



fissaggio a pavimento  
Bodenbefestigung  
floor mount  
fixation au sol



diritto  
gerade  
linear  
droit



ambienti poco aggressivi, AISI 304 satinato  
wenig aggressive Umgebung, V2A geschliffen  
little aggressive ambiente, 1.4301 brushed  
milieu peu agressif, 1.4301 brossé



fissaggio laterale  
Wandbefestigung  
wall mount  
fixation latérale



in pendenza  
schräg  
stairways  
incliné



ambienti medio aggressivi, AISI 304 / AISI 316 satinato  
mittel aggressive Umgebung, V2A / V4A geschliffen  
mid-aggressive ambiente, 1.4301 / 1.4401 brushed  
milieu moyennement agressif, 1.4301 / 1.4401 brossé



corrimano in asse  
Handlauf in Achse  
handrail within axis  
main courante dans l'axe



curvato in piano  
eben gerundet  
rounded  
cintré



ambienti molto aggressivi, AISI 316 lucidato  
stark aggressive Umgebung, V4A poliert  
massive aggressive ambiente, 1.4401 polished  
milieu très agressif, 1.4401 poli miroir



corrimano fuori asse  
Handlauf außer Achse  
handrail off-axis  
main courante déportée



calandrato  
gewendelt  
coiled  
hélicoïdal

### it | INTERVALLI DI PULIZIA

La pulizia di prodotti usati in ambienti interni deve essere fatta prima che si crei un eccessivo accumulo di sporco e impronte, in modo tale che lo lavoro di pulizia sia ridotto al minimo.

In caso di utilizzo in ambienti esterni, il materiale é esposto a numerosi agenti aggressivi:

- Atmosfere marine
- Ambienti con forte inquinamento industriale
- Spruzzi di acqua con sale antighiaccio stradale
- Forte inquinamento da traffico

In presenza di almeno uno dei fattori sopracitati, gli intervalli di pulizia dipendono dalla concentrazione degli stessi.

**In caso di montaggio in prossimità del mare consigliamo l'uso di AISI 316 LUCIDATO!**

### de | REINIGUNGSINTERVALLE

Die Reinigung von Objekten im Innenbereich hängt von der jeweiligen Verschmutzung ab und sollte dahingehend ausgeführt werden, dass der Aufwand dieselbe zu entfernen auf ein Minimum reduziert werden kann.

Die Reinigung von Objekten im Außenbereich hängt von einer Vielzahl einwirkender Faktoren ab:

- Salzhaltige Atmosphäre in Meeresnähe
- Gebiete mit industriellen Verschmutzungen
- Streusalz-Wasserspritzer in Straßennähe
- Abgaspartikel im Straßenverkehr

Die angeführten Punkte beinhalten lediglich die wichtigsten Faktoren, die zu einer Verschmutzung des Edelstahls führen können.

Die Reinigung bei Vorhandensein von mindestens einem der oben angeführten Punkte ist von der Konzentration des selben abhängig.

**Bei Montage eines Objektes in Meeresnähe wird die Verwendung von AISI 316 POLIERT empfohlen!**

### en | CLEANING INTERVALS

The cleaning of indoor products, depends from the pollution and should be done often enough as to reduce cleaning effort.

The cleaning of outdoor products depends from a number of factors:

- saline atmosphere close to the sea
- areas with industrial pollution
- splashes of water with road-salt
- road traffic pollution

The above factors can lead to a pollution of stainless steel. Cleaning in the presence of at least one of the above listed factors depends from the concentration of the same.

**We recommend the use of stainless steel AISI 316 POLISHED in marine areas!**

### fr | INTERVALLES DE NETTOYAGE

Le nettoyage des objets en intérieur dépend des conditions de saleté et devrait être fait de manière à ce que l'effort de nettoyage soit réduit au minimum. Le nettoyage d'objets en extérieur dépend de nombreux facteurs:

- Atmosphère saline à proximité de la mer
- Zones à forte saleté industrielle
- Éclaboussures d'eau des routes avec sel anti-gel
- Particules d'échappement du fait de la circulation routière

Tous ces facteurs peuvent conduire à une pollution de l'acier inox. En présence de l'un au moins de ces facteurs, les intervalles de nettoyage seront fonction de leur concentration.

**En cas d'installation à proximité de la mer, nous conseillons l'utilisation d'acier inox AISI 316 POLI!**

Con riserva di modifiche tecniche e salvo errori di stampa. | Technische Verbesserungen, sowie Satz- und Druckfehler vorbehalten. | Technical improvement under reserve. Subject to typographical error. | Avec réserve de modifications techniques et sauf erreurs d'impression.



**WOLFSGRUBER srl / GmbH**  
via campi della Rienza 15 Rienzfildweg  
I-39031 Brunico - Bruneck (BZ)  
T +39 0474 55 22 31  
info@wolfsgruber.it

**[www.wolfsgruber.it](http://www.wolfsgruber.it)**