

HEAVY DUTY 707

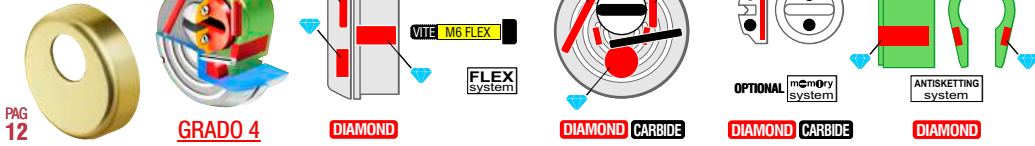

DIAMOND

ROK SFERIK
PAT. PEND.



PAG 12

GRADO 4

DIAMOND

DIAMOND CARBIDE

DIAMOND CARBIDE

DIAMOND

MONOLITO KRIPTON

ROK SFERIK
PAT. PEND.



PAG 22

GRADO 4

CARBIDE

Mn CARBIDE

MONOLITO

ROK SFERIK
PAT. PEND.



PAG 32

GRADO 4

HS CARBIDE

Mn

RwS

ROK SFERIK
PAT. PEND.

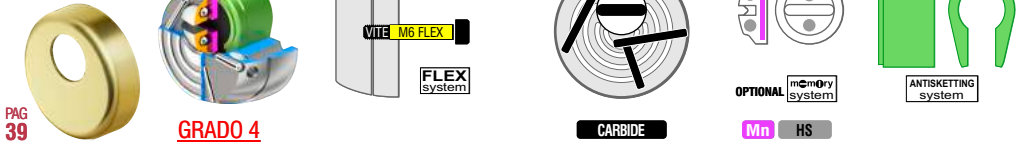

PAG 39

GRADO 4

CARBIDE

Mn HS

STONE

ROK SFERIK
PAT. PEND.

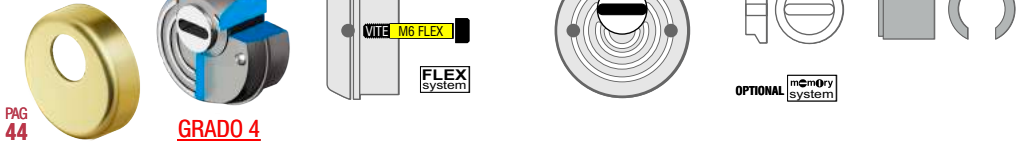

PAG 44

GRADO 4

BDS

ROK SFERIK
PAT. PEND.

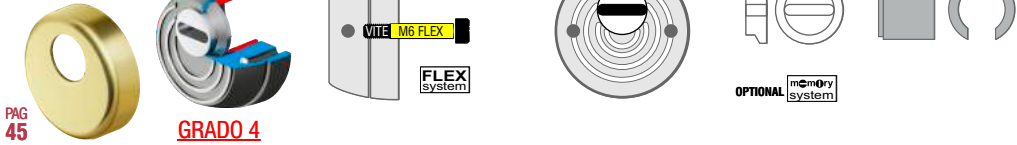

PAG 45

GRADO 4

RB

ROK SFERIK
PAT. PEND.

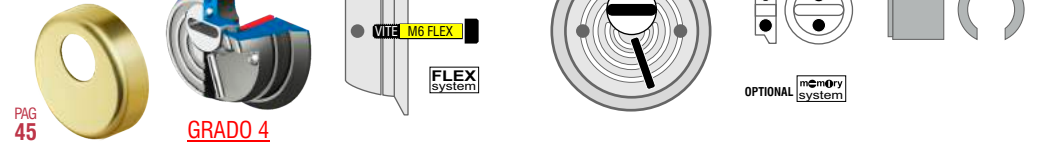

PAG 45

GRADO 4

MAGNETIC LOCK PROTECTIONS

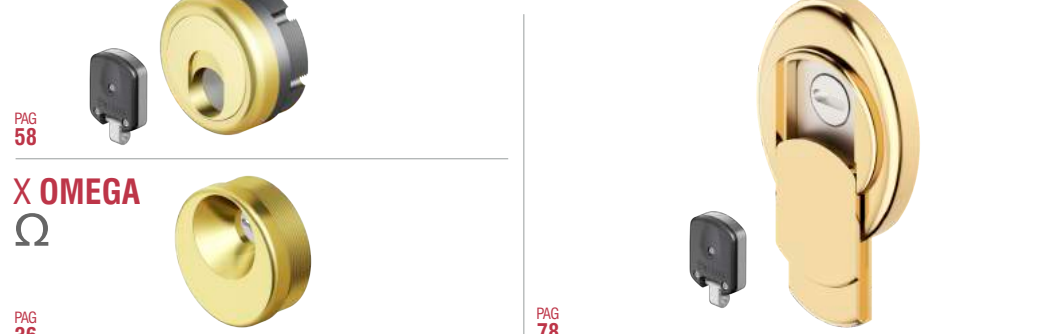

PAG 58

X OMEGA

Ω



PAG 56

PAG 78

ELECTRONIC CYLINDER LOCK PROTECTION



PAG 84

PAG 100

ACCESSORIES



PAG 124

PAG 130



ROK SFERIK

PAT. PEND.



GRADO 4



PAG



VIDEO

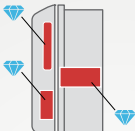

DIAMOND



DIAMOND CARBIDE



OPTIONAL memory system

DIAMOND CARBIDE



ANTISKETTING system

DIAMOND

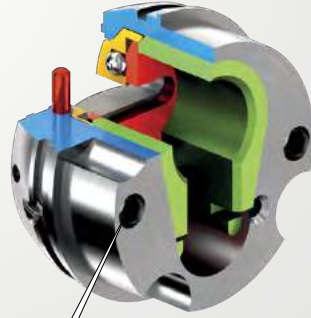

FLEX system

OPTIONAL MEMORY SYSTEM

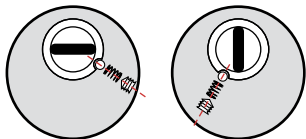

FLEX SYSTEM



5 VOLTE PIU' RESISTENTE DELLE VITI TRADIZIONALI 12.9



PAG



PAG



PAG

SUPER TOP 86x66



TOP 88x68



MONOLITO 88x68



MILANO Ø 65



MONOLITO E Ø 65



QUADRA 65x65



QUADRY 84x64





FILETTATO
Ø50
SFERIK

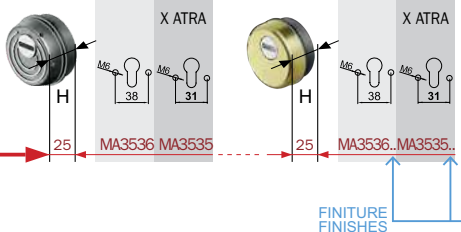

- A1561..**
- 0 Cromo lucido Bright Chrome
 - 1 Cromo satinato Satin Chrome
 - 2 Bronzo Bronze
 - 3 PVD Ottone PVD Brass
 - 4 Ottone satinato Satin Brass
 - 5 Bronzo satinato Satin Bronze
 - 6 Inox satinato Stainless steel

SUPER TOP
56x66

TOP
88x68

MONOLITO
88x68

MILANO
Ø 65

MONOLITO E
Ø 65

QUADRA
65x65

QUADRY
84x64

7 min

11 min

5 min

9 min

5 min

11 min

5 min

11 min

5 min

11 min

5 min

11 min

BKD291	25	..	BKD391	25	..	BKD291 8 25..
BKD290	25	..	BKD390	25
BKD271	25	..	BKD371	25
BKD270	25	..	BKD370	25
BKD251	25	..	BKD351	25
BKD250	25	..	BKD350	25
BKD261	25	..	BKD361	25
BKD260	25	..	BKD360	25
BKD28A	25	..	BKD38A	25
BKD251Q	25	..	BKD351Q	25
BKD250Q	25	..	BKD350Q	25
BKD251W	25	..	BKD351W	25
BKD250W	25	..	BKD350W	25

ESEMPIO DI CODICE PER VITI M8

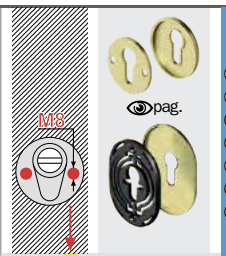
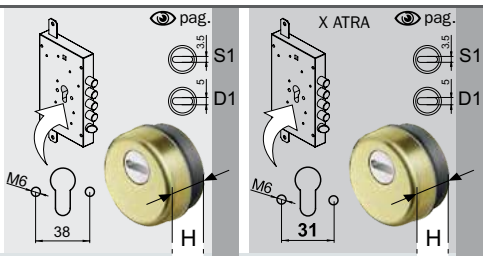

- FINITURE FINISHES**
- C Cromo lucido Bright Chrome
 - T Cromo satinato Satin Chrome
 - B Bronzo Bronze
 - 2 PVD Ottone PVD Brass
 - 4 Ottone satinato Satin Brass
 - 5 Bronzo satinato Satin Bronze
 - 6 Inox satinato Stainless steel

- C Cromo lucido Bright Chrome
- T Cromo satinato Satin Chrome
- B Bronzo Bronze
- 2 PVD Ottone PVD Brass
- 5 Bronzo satinato Satin Bronze
- 6 Inox satinato Stainless steel



PAT. PEND.

Ø50

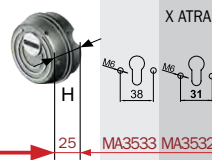

X ATRA

25

MA3533 MA3532

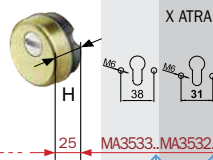

X ATRA

25

MA3533..MA3532..



A1561..

- C Cromo lucido
Bright Chrome
- T Cromo satinato
Satin Chrome
- B Bronzo
- 2 PVD Otone
PVD Brass
- TT Otone satinato
Satin Brass
- BS Bronzo satinato
Satin Bronze
- IT Inox satinato
Stainless steel

FINITURE FINISHES

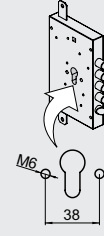

pag.

S1
D1

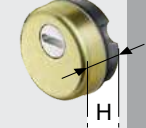

BKT291D 25 ..

BKT290D 25 ..

BKT271D 25 ..

BKT270D 25 ..

BKT201D 25 ..

BKT200D 25 ..

BKT211D 25 ..

BKT210D 25 ..

BKT28AD 25 ..

BKT251QD 25 ..

BKT250QD 25 ..

BKT251WD 25 ..

BKT250WD 25 ..

X ATRA

pag.

S1
D1

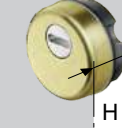
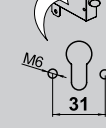

BKT391D 25 ..

BKT390D 25 ..

BKT371D 25 ..

BKT370D 25 ..

BKT301D 25 ..

BKT300D 25 ..

BKT311D 25 ..

BKT310D 25 ..

BKT38AD 25 ..

BKT351QD 25 ..

BKT350QD 25 ..

BKT351WD 25 ..

BKT350WD 25 ..



pag.

FINITURE FINISHES

- C Cromo lucido
Bright Chrome
- T Cromo satinato
Satin Chrome
- B Bronzo
- 2 PVD Otone
PVD Brass
- TT Otone satinato
Satin Brass
- BS Bronzo satinato
Satin Bronze
- IT Inox satinato
Stainless steel

- C Cromo lucido
Bright Chrome
- T Cromo satinato
Satin Chrome
- 2 PVD Otone
PVD Brass
- BS Bronzo satinato
Satin Bronze
- IT Inox satinato
Stainless steel

- C Cromo lucido
Bright Chrome
- T Cromo satinato
Satin Chrome
- B Bronzo
- 2 PVD Otone
PVD Brass
- BS Bronzo satinato
Satin Bronze
- IT Inox satinato
Stainless steel

SUPER TOP
56x66

TOP
88x68

MONOLITO
88x68

MILANO
Ø 65

MONOLITO E
Ø 65

QUADRA
65x65

QUADRY
84x64

KT2896TK h7
KT2897TK h11

7 min

11 min

KT2002TK h5
KT2001TK h9

5 min

9 min

A2815 h5
A2816 h11

5 min

11 min

A1612TK h5
A1936TK h11

5 min

11 min

A2199TK

5 min

11 min

A3171TK h5
A3060TK h11

KT3481TK h5
KT3482TK h11

5 min

11 min

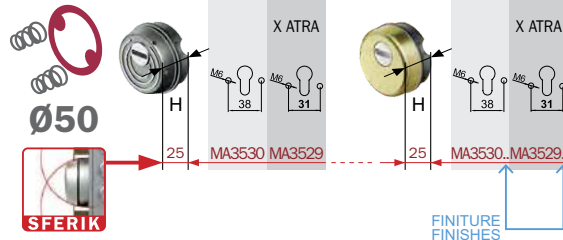

- A1561..**
- C Cromo lucido Bright Chrome
 - T Cromo satinato Satin Chrome
 - B Bronzo Bronze
 - 2 PVD Ottonne PVD Brass
 - TT Ottonne satinato Satin Brass
 - BS Bronzo satinato Satin Bronze
 - IT Inox satinato Stainless steel

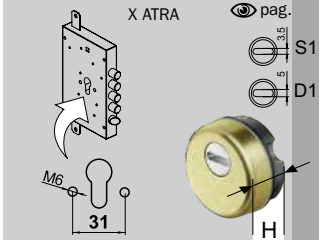
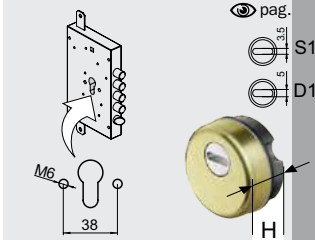

- FINITURE FINISHES**
- C Cromo lucido Bright Chrome
 - T Cromo satinato Satin Chrome
 - B Bronzo Bronze
 - 2 PVD Ottonne PVD Brass
 - TT Ottonne satinato Satin Brass
 - BS Bronzo satinato Satin Bronze
 - IT Inox satinato Stainless steel

SUPER TOP 56x66			KT2896TK h7 KT2897TK h11
TOP 88x68			KT2002TK h5 KT2001TK h9
MONOLITO 88x68			A2815 h5 A2816 h11
MILANO Ø 65			A1612TK h5 A1936TK h11
MONOLITO E Ø 65			A2199TK
QUADRA 65x65			A3171TK h5 A3060TK h11
QUADRY 84x64			KT3481TK h5 KT3482TK h11

	7 min		
	11 min		
	5 min		
	9 min		
	5 min		
	11 min		
	5 min		
	11 min		
	5 min		
	11 min		
	5 min		
	11 min		

BKF291D	25	..		BKF391D	25
BKF290D	25	..		BKF390D	25
BKF271D	25	..		BKF371D	25
BKF270D	25	..		BKF370D	25
BKF201D	25	..		BKF301D	25
BKF200D	25	..		BKF300D	25
BKF211D	25	..		BKF311D	25
BKF210D	25	..		BKF310D	25
BKF28AD	25	..		BKF38AD	25
BKF251QD	25	..		BKF351QD	25
BKF250QD	25	..		BKF350QD	25
BKF251WD	25	..		BKF351WD	25
BKF250WD	25	..		BKF350WD	25

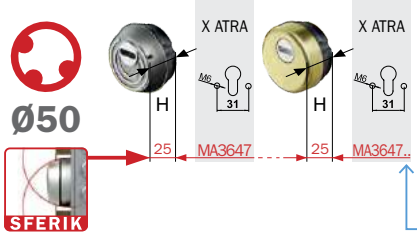
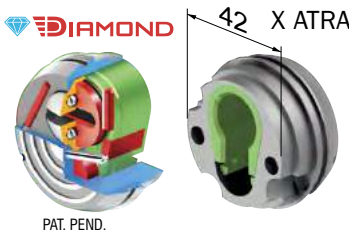

- A1561..**
- 1 Cromo lucido Bright Chrome
 - 1 Cromo satinato Satin Chrome
 - 2 Bronzo Bronze
 - 2 PVD Ottone PVD Brass
 - 1 Ottone satinato Satin Brass
 - 1 Bronzo satinato Satin Bronze
 - 1 Inox satinato Stainless steel

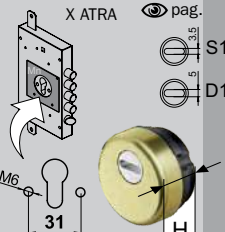
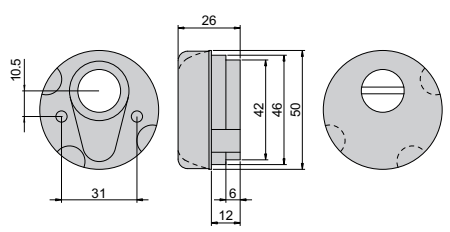

- FINITURE FINISHES**
- C Cromo lucido Bright Chrome
 - T Cromo satinato Satin Chrome
 - B Bronzo Bronze
 - 2 PVD Ottone PVD Brass
 - 11 Ottone satinato Satin Brass
 - BS Bronzo satinato Satin Bronze
 - IT Inox satinato Stainless steel

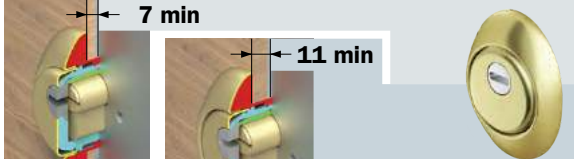

BK321ST 25

BK320ST 25

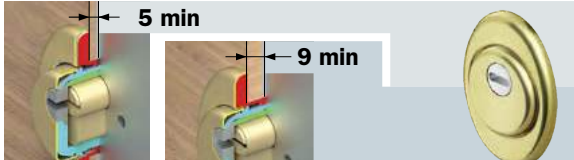
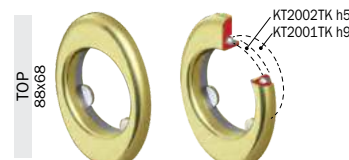

BK321T 25

BK320T 25

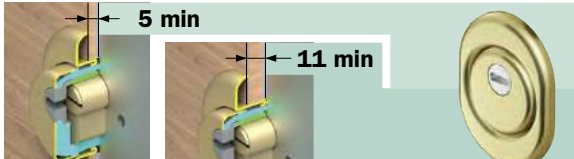
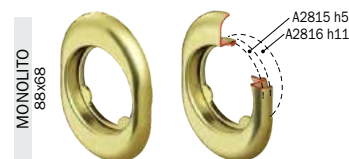

BK321 25

BK320 25



BK321M 25

BK320M 25

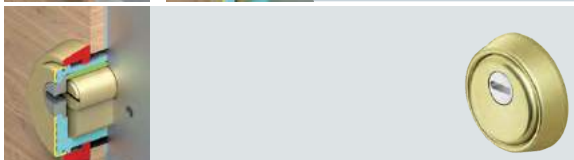
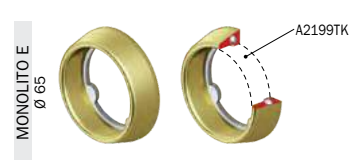

BK321E 25

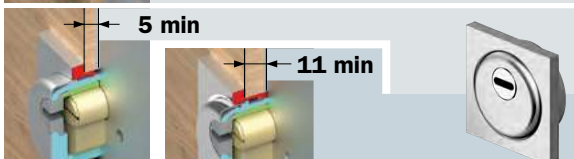
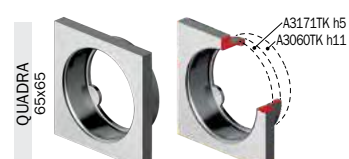

BK321Q 25

BK320Q 25

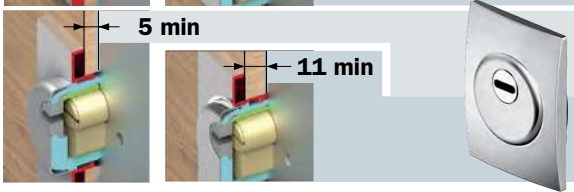
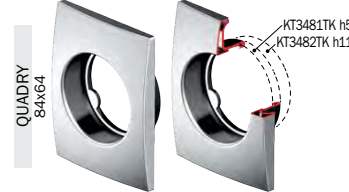

BK321W 25

BK320W 25



- FINITURE FINISHES**
- C Cromo lucido Bright Chrome
 - T Cromo satinato Satin Chrome
 - B Bronzo Bronze
 - 2 PVD Ottone PVD Brass
 - BS Bronzo satinato Satin Bronze
 - IT Inox satinato Stainless steel



DIAMOND



PAT. PEND.

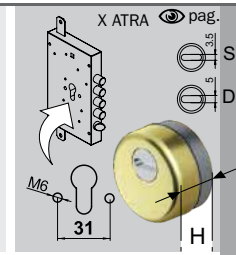
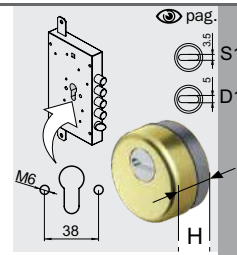
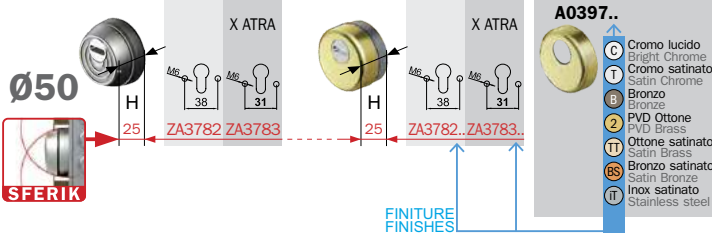

- FINITURE FINISHES
- C Cromo lucido
 - T Bright Chrome
 - S Cromo satinato
 - B Satin Chrome
 - B Bronzo
 - 2 PVD Ottone
 - TT PVD Brass
 - SS Ottone satinato
 - TT Satin Brass
 - SS Bronzo satinato
 - TT Satin Bronze
 - SS Inox satinato
 - TT Stainless Steel

	RKD16 25 .. P	RKD68 25 .. P	RKD16 8 25.. ESEMPIO CODICE
	RKD16W 25 .. P	RKD68W 25 .. P	ESEMPIO DI CODICE PER VITI M8 EXAMPLE OF CODE FOR FIXING M8		..
	RKD16K 25 .. P	RKD68K 25 .. P			..



DIAMOND



PAT. PEND.

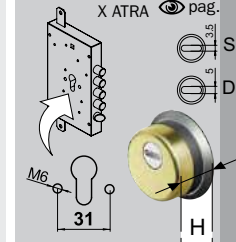
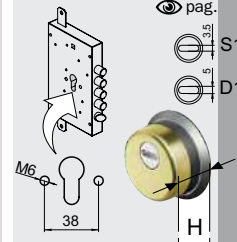
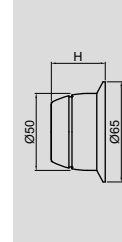
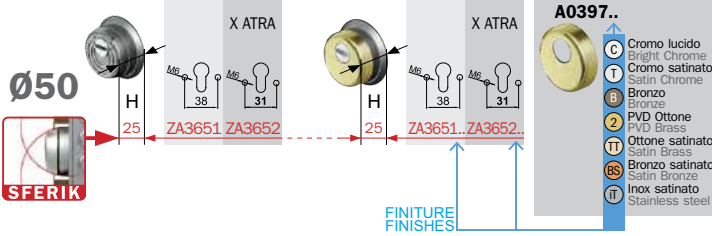

- FINITURE FINISHES
- C Cromo lucido
 - T Bright Chrome
 - S Cromo satinato
 - B Satin Chrome
 - B Bronzo
 - 2 PVD Ottone
 - TT PVD Brass
 - SS Ottone satinato
 - TT Satin Brass
 - SS Bronzo satinato
 - TT Satin Bronze
 - SS Inox satinato
 - TT Stainless Steel

	RKD42 25 .. P	RKD48 25 .. P	RKD42 8 25.. ESEMPIO CODICE
	RKD42W 25 .. P	RKD48W 25 .. P	ESEMPIO DI CODICE PER VITI M8 EXAMPLE OF CODE FOR FIXING M8		..
	RKD42K 25 .. P	RKD48K 25 .. P			..

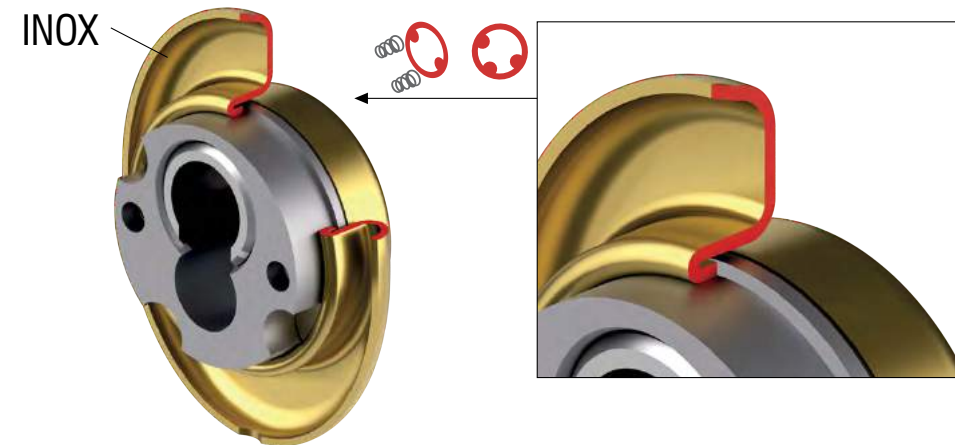
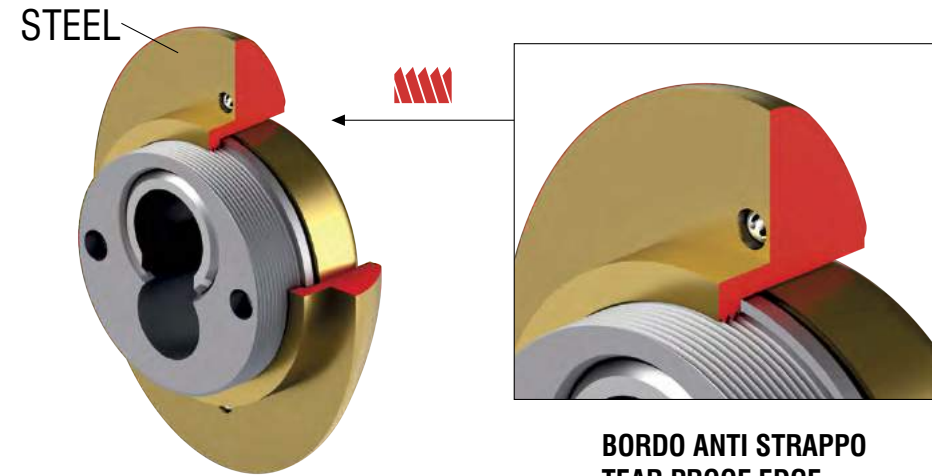
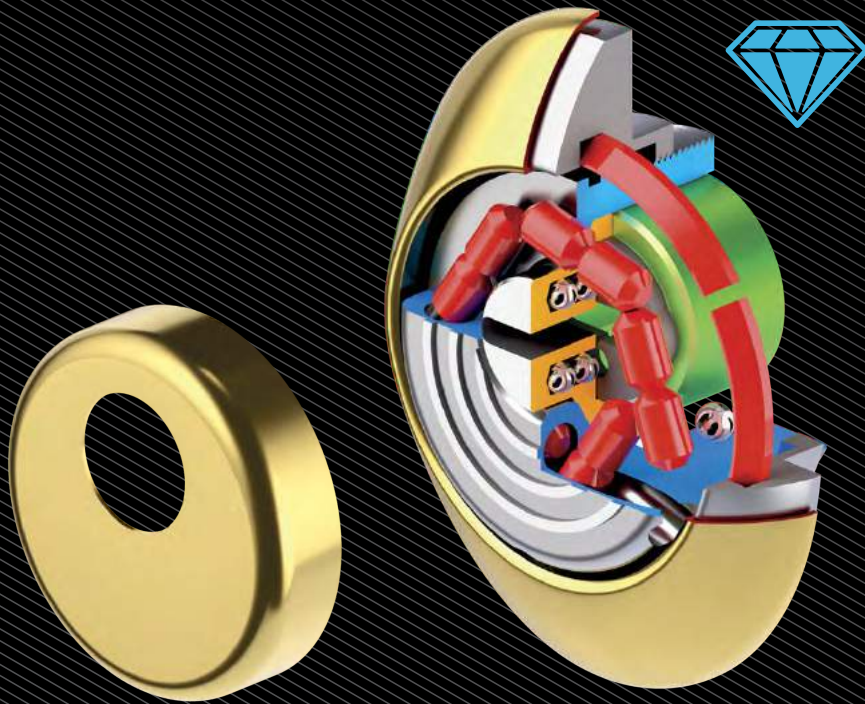

CLS5

NEW REFERENCE TESTED

CLASS 5

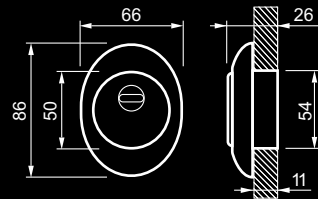

- FINITURE:
FINISHING:
- C** Cromo lucido
Bright Chrome
 - T** Cromo satinato
Satin Chrome
 - B** Bronzo
Bronze
 - 2** PVD Ottone
PVD Brass



SUPER TOP

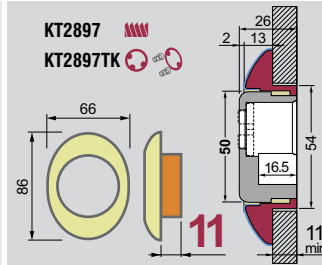
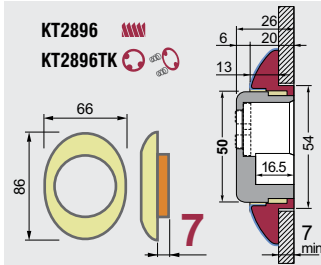

TOP

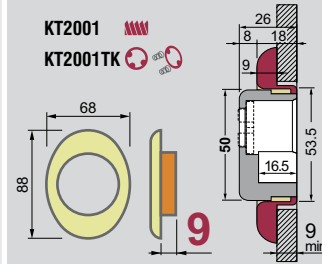
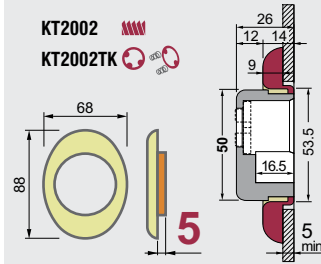

MONOLITO

OPTIONAL
A2073
SPESORE 5mm
SPACER 5mm
PAG

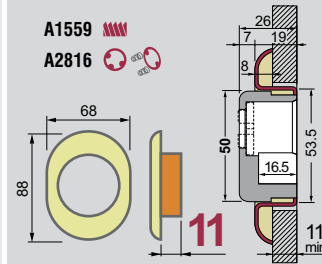
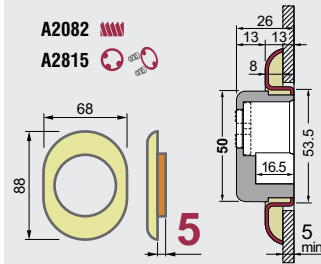

STONE

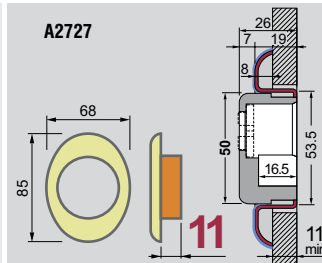
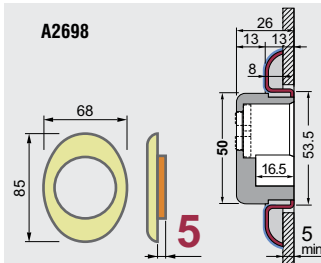

MILANO

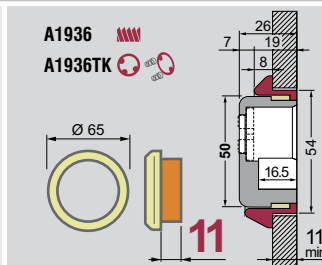
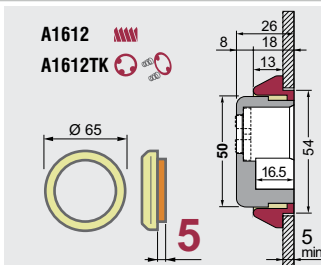

MONOLITO E

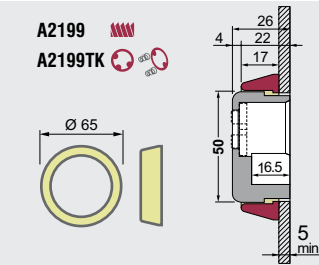

QUADRA

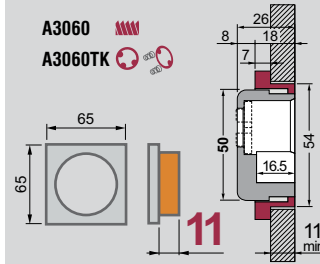
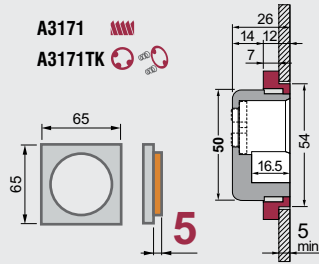

QUADRY

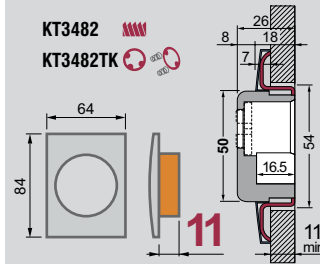
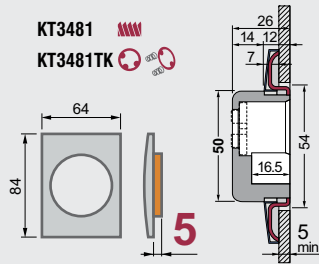

QUADRY P

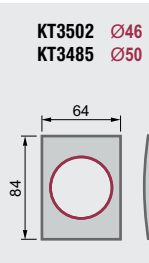

KUBO

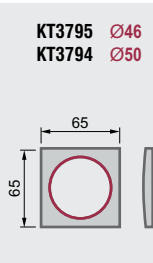

STANDARD

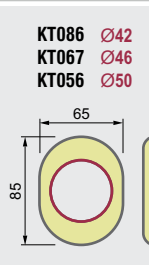

MONOLITO KRIPTON

ROK SFERIK

PAT. PEND.



GRADO 4



PAG

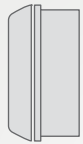

CARBIDE

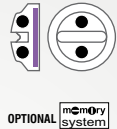

OPTIONAL memory system

Mn CARBIDE



ANTISKETTING system

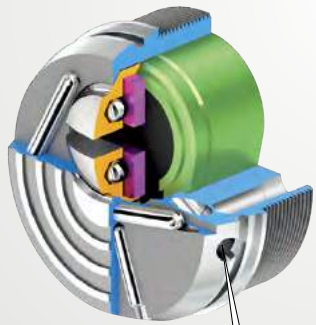

memory system
OPTIONAL

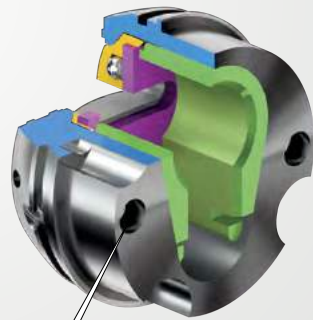

FLEX system

OPTIONAL
MEMORY SYSTEM

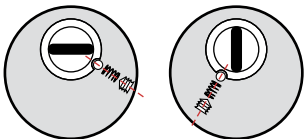

FLEX SYSTEM



5 VOLTE PIU' RESISTENTE DELLE VITI TRADIZIONALI 12.9

MONOLITO KRIPTON



PAG



PAG



PAG

SUPER TOP
86x66



TOP
88x68



MONOLITO
88x68



MILANO
Ø 65



MONOLITO E
Ø 65



QUADRA
65x65



QUADRY
84x64



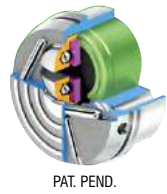

PAT. PEND.



H	MA3633	MA3634
20	MA3633	MA3634
25	MA3627	MA3626
35	MA3626	MA3625
45	MA3628	MA3627

H	MA3633..	MA3634..
20	MA3633..	MA3634..
25	MA3627..	MA3626..
35	MA3626..	MA3625..
45	MA3628..	MA3627..

A2209.. H 20
A1561.. H 25/35/45

C	Cromo lucido	Bright Chrome
T	Cromo satinato	Satin Chrome
B	Bronzo	Bronze
2	PVD Ottone	PVD Brass
TT	Ottone satinato	Satin Brass
BS	Bronzo satinato	Satin Bronze
IT	Inox satinato	Stainless steel

SUPER TOP 56x66	KT2896 h7 KT2897 h11	
TOP 88x68	KT2002 h5 KT2001 h9	
MONOLITO 88x68	A2082 h5 A1559 h11	
MILANO Ø 65	A1612 h5 A1936 h11	
MONOLITO E Ø 65	A2199	
QUADRA 65x65	A3171 h5 A3060 h11	
QUADRY 84x64	KT3481 h5 KT3482 h11	

7 min	11 min	
5 min	9 min	
5 min	11 min	
5 min	11 min	
5 min	11 min	
5 min	11 min	
5 min	11 min	
5 min	11 min	

BD291N 20	BD391N 20	BD291N 25	BD391N 25	BD291N 35	BD391N 35	BD291N 45	BD391N 45	BD290N 20	BD390N 20	BD290N 25	BD390N 25	BD290N 35	BD390N 35	BD290N 45	BD390N 45	BD271N 20	BD371N 20	BD271N 25	BD371N 25	BD271N 35	BD371N 35	BD271N 45	BD371N 45	BD270N 20	BD370N 20	BD270N 25	BD370N 25	BD270N 35	BD370N 35	BD270N 45	BD370N 45	BD251N 20	BD351N 20	BD251N 25	BD351N 25	BD251N 35	BD351N 35	BD251N 45	BD351N 45	BD250N 20	BD350N 20	BD250N 25	BD350N 25	BD250N 35	BD350N 35	BD250N 45	BD350N 45	BD261N 20	BD361N 20	BD261N 25	BD361N 25	BD261N 35	BD361N 35	BD261N 45	BD361N 45	BD260N 20	BD360N 20	BD260N 25	BD360N 25	BD260N 35	BD360N 35	BD260N 45	BD360N 45	BD28AN 20	BD38AN 20	BD28AN 25	BD38AN 25	BD28AN 35	BD38AN 35	BD28AN 45	BD38AN 45	BD251QN 20	BD351QN 20	BD251QN 25	BD351QN 25	BD251QN 35	BD351QN 35	BD251QN 45	BD351QN 45	BD250QN 20	BD350QN 20	BD250QN 25	BD350QN 25	BD250QN 35	BD350QN 35	BD250QN 45	BD350QN 45	BD251WN 20	BD351WN 20	BD251WN 25	BD351WN 25	BD251WN 35	BD351WN 35	BD251WN 45	BD351WN 45	BD250WN 20	BD350WN 20	BD250WN 25	BD350WN 25	BD250WN 35	BD350WN 35	BD250WN 45	BD350WN 45
-----------	-----------	-----------	-----------	-----------	-----------	-----------	-----------	-----------	-----------	-----------	-----------	-----------	-----------	-----------	-----------	-----------	-----------	-----------	-----------	-----------	-----------	-----------	-----------	-----------	-----------	-----------	-----------	-----------	-----------	-----------	-----------	-----------	-----------	-----------	-----------	-----------	-----------	-----------	-----------	-----------	-----------	-----------	-----------	-----------	-----------	-----------	-----------	-----------	-----------	-----------	-----------	-----------	-----------	-----------	-----------	-----------	-----------	-----------	-----------	-----------	-----------	-----------	-----------	-----------	-----------	-----------	-----------	-----------	-----------	-----------	-----------	------------	------------	------------	------------	------------	------------	------------	------------	------------	------------	------------	------------	------------	------------	------------	------------	------------	------------	------------	------------	------------	------------	------------	------------	------------	------------	------------	------------	------------	------------	------------	------------

ESEMPIO DI CODICE PER VITI M8

ESEMPIO CODICE

ESEMPIO CODICE

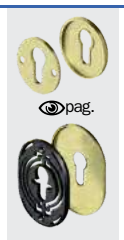

FINITURE FINISHES

C	Cromo lucido	Bright Chrome
T	Cromo satinato	Satin Chrome
B	Bronzo	Bronze
2	PVD Ottone	PVD Brass
TT	Ottone satinato	Satin Brass
BS	Bronzo satinato	Satin Bronze
IT	Inox satinato	Stainless steel

Ø50

PAT. PEND. **SFERIK**

	X ATRA	X CR	X ATRA	X CR
H	MA3636	MA3635	MA2366	
20				
25	MA3524	MA3523	MA2051	
35	MA3630	MA3629	MA2055	
45	MA3632	MA3631	MONOLITO VERSIONE 2015	

A2209.. H 20
A1561.. H 25/35/45

- Cromo lucido Bright Chrome
- Cromo satinato Satin Chrome
- Bronzo Bronze
- PVD Ottone PVD Brass
- Ottone satinato Satin Brass
- Bronzo satinato Satin Bronze
- Inox satinato Stainless steel

Model	Top	Monolito	Milano	Monolito E	Quadra	Quadry
SUPER TOP	56x66					
TOP	88x68					
MONOLITO	88x68					
MILANO	Ø 65					
MONOLITO E	Ø 65					
QUADRA	65x65					
QUADRY	84x64					

Model	Top	Monolito	Milano	Monolito E	Quadra	Quadry
SUPER TOP	7 min / 11 min					
TOP	5 min / 9 min					
MONOLITO	5 min / 11 min					
MILANO	5 min / 11 min					
MONOLITO E						
QUADRA	5 min / 11 min					
QUADRY	5 min / 11 min					

Model	Top	Monolito	Milano	Monolito E	Quadra	Quadry
BDT291N	20	BDT391N	20			
BDT291N	25	BDT391N	25			
BDT291N	35	BDT391N	35			
BDT291N	45	BDT391N	45			
BDT290N	20	BDT390N	20			
BDT290N	25	BDT390N	25			
BDT290N	35	BDT390N	35			
BDT290N	45	BDT390N	45			
BDT271N	20	BDT371N	20			
BDT271N	25	BDT371N	25			
BDT271N	35	BDT371N	35			
BDT271N	45	BDT371N	45			
BDT270N	20	BDT370N	20			
BDT270N	25	BDT370N	25			
BDT270N	35	BDT370N	35			
BDT270N	45	BDT370N	45			
BD201N	20	BD301N	20	BD401 20		
BD201N	25	BD301N	25	BD401 25		
BD201N	35	BD301N	35	BD401 35		
BD201N	45	BD301N	45			
BD200N	20	BD300N	20	BD400 20		
BD200N	25	BD300N	25	BD400 25		
BD200N	35	BD300N	35	BD400 35		
BD200N	45	BD300N	45			
BDT211N	20	BDT311N	20			
BDT211N	25	BDT311N	25			
BDT211N	35	BDT311N	35			
BDT211N	45	BDT311N	45			
BDT210N	20	BDT310N	20			
BDT210N	25	BDT310N	25			
BDT210N	35	BDT310N	35			
BDT210N	45	BDT310N	45			
BDT28AN	20	BDT38AN	20			
BDT28AN	25	BDT38AN	25			
BDT28AN	35	BDT38AN	35			
BDT28AN	45	BDT38AN	45			
BDT251QN	20	BDT351QN	20			
BDT251QN	25	BDT351QN	25			
BDT251QN	35	BDT351QN	35			
BDT251QN	45	BDT351QN	45			
BDT250QN	20	BDT350QN	20			
BDT250QN	25	BDT350QN	25			
BDT250QN	35	BDT350QN	35			
BDT250QN	45	BDT350QN	45			
BDT251WN	20	BDT351WN	20			
BDT251WN	25	BDT351WN	25			
BDT251WN	35	BDT351WN	35			
BDT251WN	45	BDT351WN	45			
BDT250WN	20	BDT350WN	20			
BDT250WN	25	BDT350WN	25			
BDT250WN	35	BDT350WN	35			
BDT250WN	45	BDT350WN	45			

FINITURE FINISHES

- Cromo lucido Bright Chrome
- Cromo satinato Satin Chrome
- Bronzo Bronze
- PVD Ottone PVD Brass
- Bronzo satinato Satin Bronze
- Satin Bronze
- Inox satinato Stainless steel

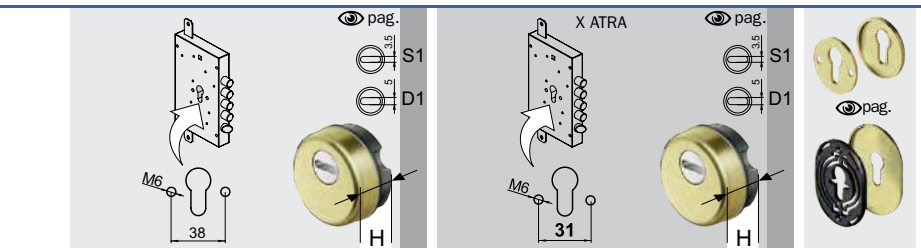
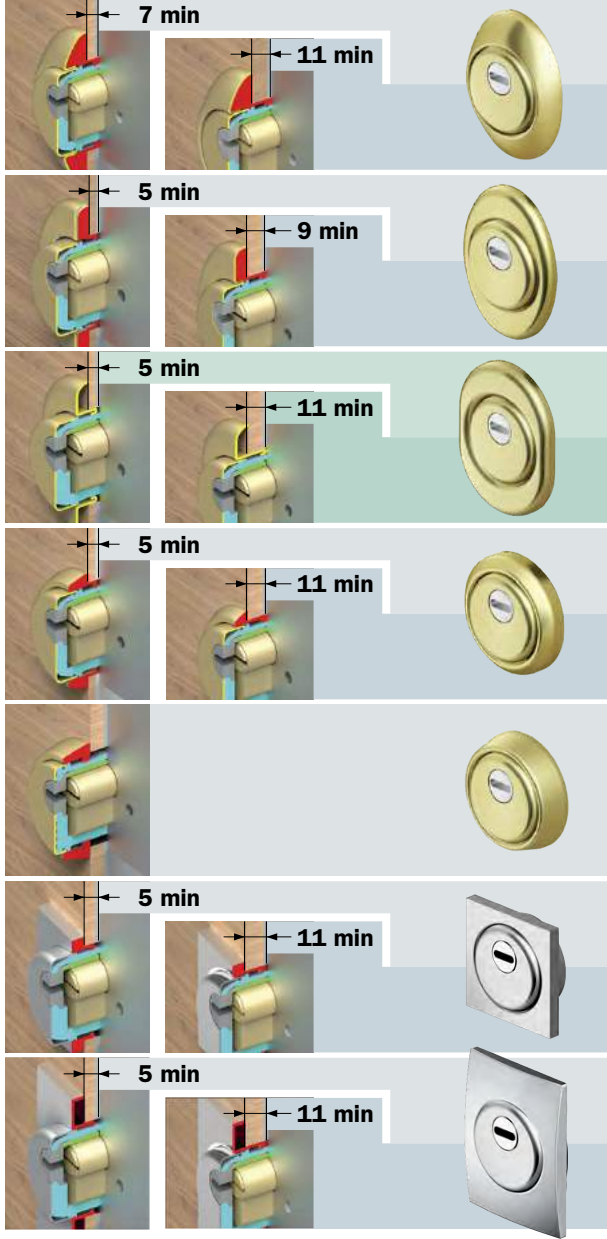
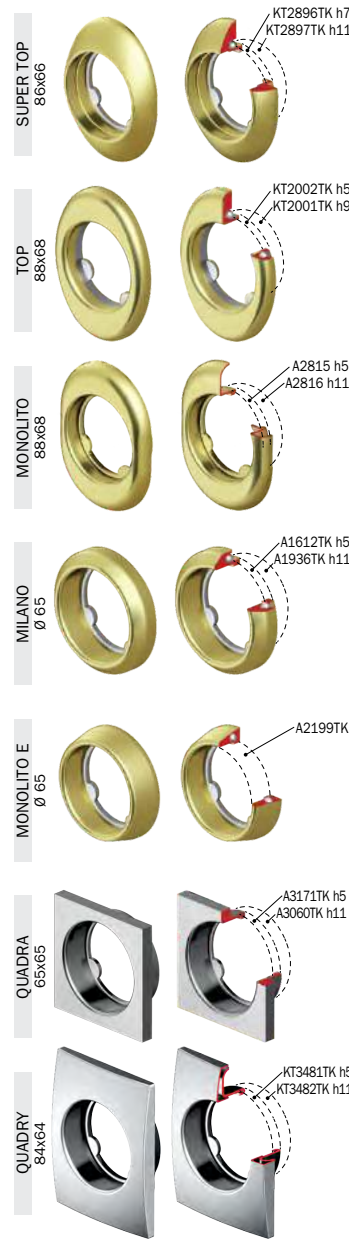
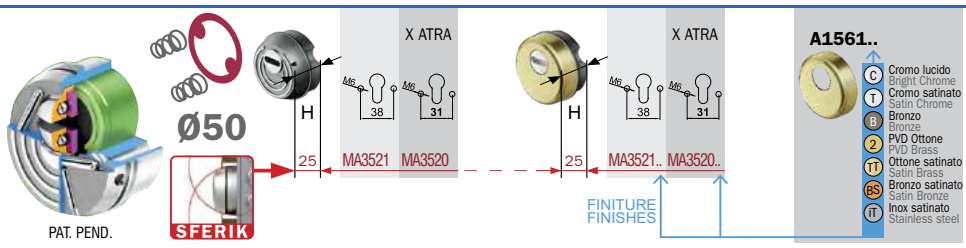

BFT291	25
BFT290	25
BFT271	25
BFT270	25
BF201	25
BF200	25
BFT211	25
BFT210	25
BFT28A	25
BFT251Q	25
BFT250Q	25
BFT251W	25
BFT250W	25

FINITURE FINISHES

Cromo lucido
Bright Chrome
Cromo satinato
Satin Chrome
Bronzo
Bronze
PVD Otone
PVD Brass
Ottone satinato
Satin Brass
Bronzo satinato
Satin Bronze
Inox satinato
Stainless steel

pag.

Cromo lucido
Bright Chrome
Cromo satinato
Satin Chrome
Bronzo
Bronze
PVD Otone
PVD Brass
Bronzo satinato
Satin Bronze
Inox satinato
Stainless steel

pag.

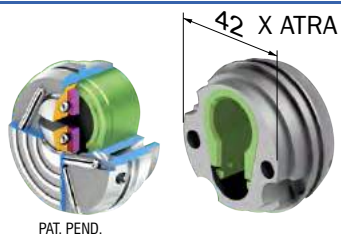

PAT. PEND.

42 X ATRA



Ø50

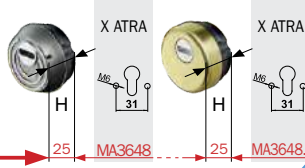

- A1561..**
- C Cromo lucido Bright Chrome
 - T Cromo satinato Satin Chrome
 - B Bronzo Bronze
 - 2 PVD Otone PVD Brass
 - TT Otone satinato Satin Brass
 - BS Bronzo satinato Satin Bronze
 - IT Inox satinato Stainless steel

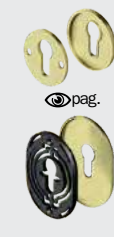
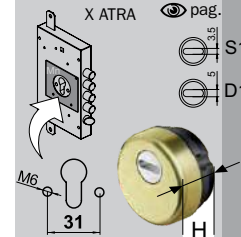
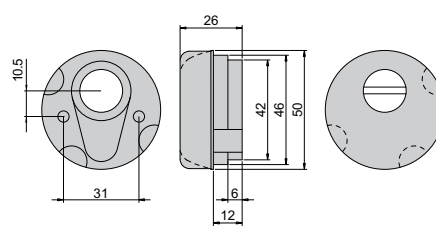

- FINITURE FINISHES**
- C Cromo lucido Bright Chrome
 - T Cromo satinato Satin Chrome
 - B Bronzo Bronze
 - 2 PVD Otone PVD Brass
 - TT Otone satinato Satin Brass
 - BS Bronzo satinato Satin Bronze
 - IT Inox satinato Stainless steel



KT2896TK h7
KT2897TK h11

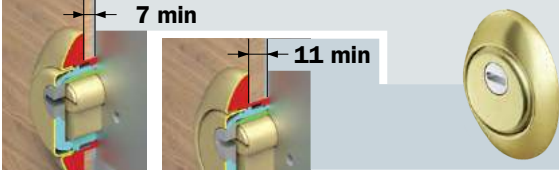

BD321ST 25

BD320ST 25

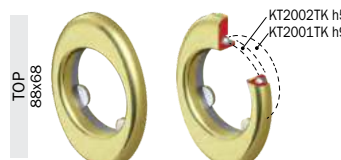

KT2002TK h5
KT2001TK h9

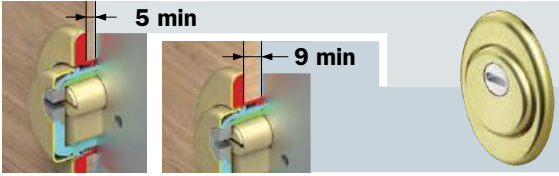

BD321T 25

BD320T 25

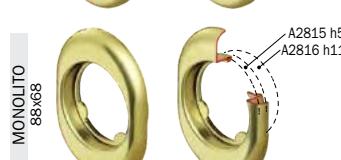

A2815 h5
A2816 h11

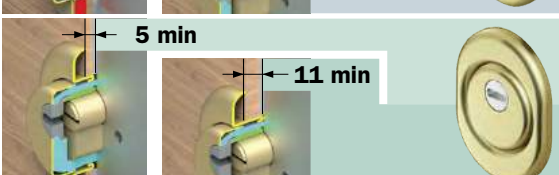

BD321N 25

BD320N 25

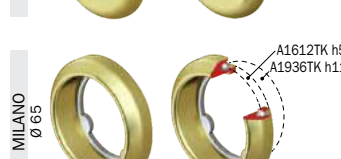

A1612TK h5
A1936TK h11



BD321M 25

BD320M 25



A2199TK



BD321E 25

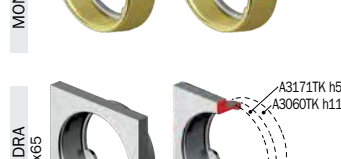

A3171TK h5
A3060TK h11

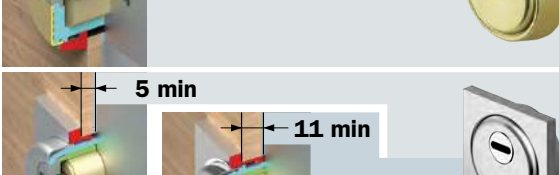

BD321Q 25

BD320Q 25



KT3481TK h5
KT3482TK h11

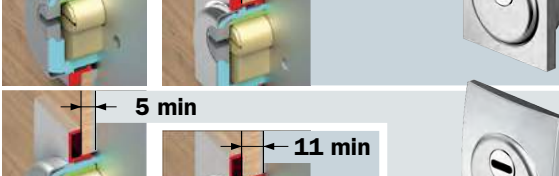

BD321W 25

BD320W 25

SUPER TOP

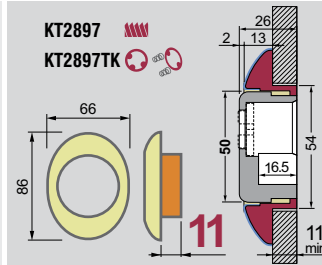
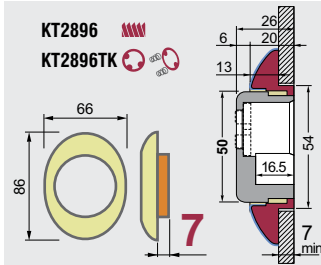

TOP

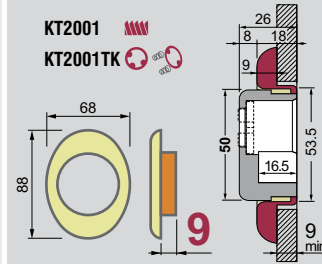
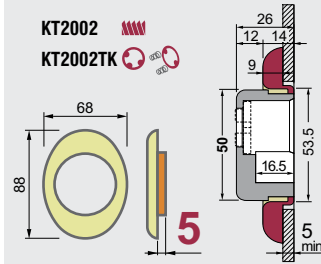

MONOLITO

OPTIONAL
A2073
SPESORE 5mm
SPACER 5mm
PAG

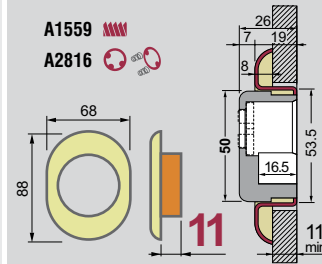
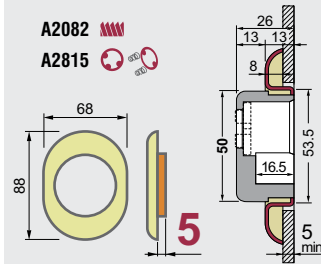

STONE

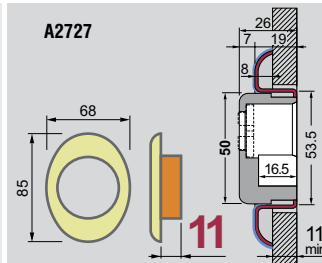
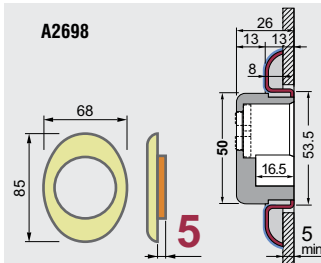

MILANO

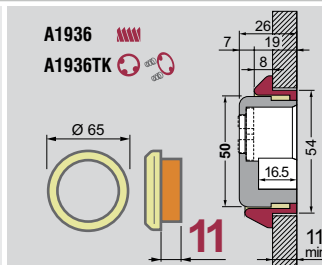
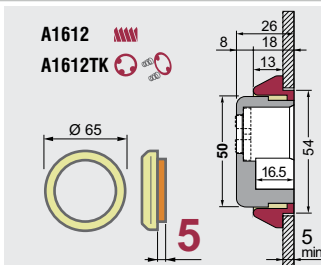

MONOLITO E

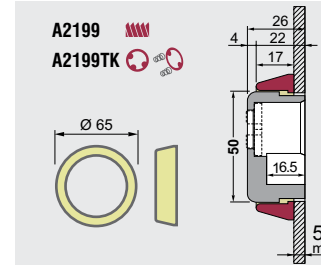

QUADRA

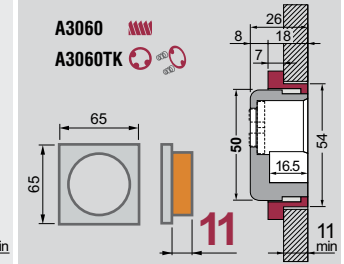
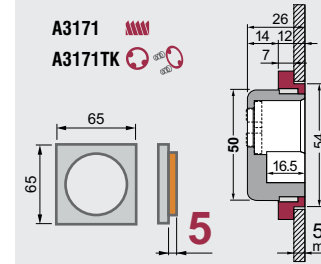

QUADRY

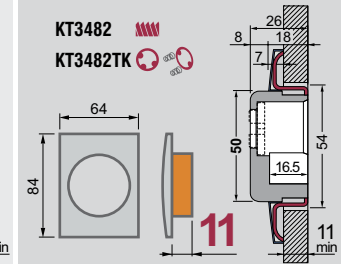
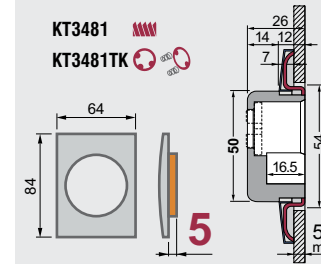

QUADRY P

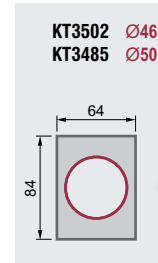

KUBO

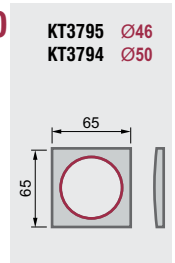

STANDARD

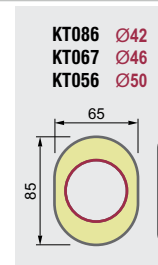

MONOLITO ROK SFERIK

PAT. PEND.



GRADO 4

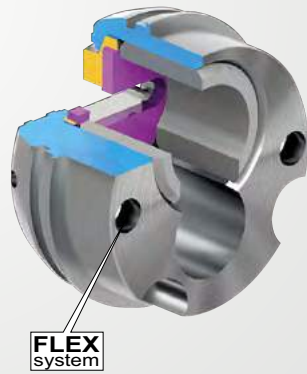
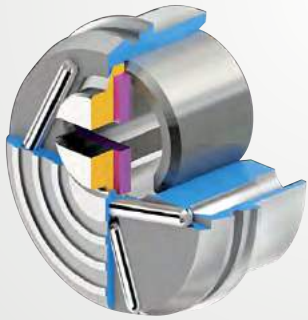
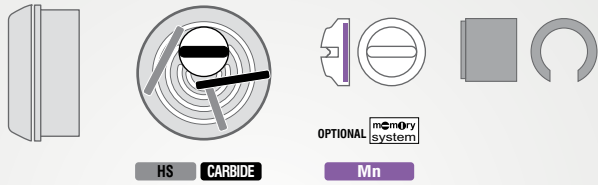

OPTIONAL
MEMORY SYSTEM

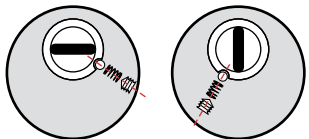

FLEX SYSTEM



MONOLITO



MONOLITO
88x68



QUADRY
84x64



FILETTATO

Ø50

PAT. PEND.

SFERIK

X ATRA

H	20	MA2371	MA2372
H	25	MA2665	MA2731
H	35	MA1927	MA1928
H	45	MA2702	

X ATRA

H	20	MA2371..	MA2372..
H	25	MA2665..	MA2731..
H	35	MA1927..	MA1928..
H	45	MA2702..	

A2209.. H 20
A1561.. H 25/35/45

FINITURE FINISHES

- C Cromo lucido Bright Chrome
- T Cromo satinato Satin Chrome
- B Bronzo Bronze
- Z PVD Ottone PVD Brass
- TT Ottone satinato Satin Brass
- BS Bronzo satinato Satin Bronze
- IT Inox satinato Stainless steel

pag. S1 D1

X ATRA pag. S1 D1

pag. pag.

BD251 20 ..

BD251 25 ..

BD251 35 ..

BD251 45 ..

BD250 20 ..

BD250 25 ..

BD250 35 ..

BD250 45 ..

BD251W 20 ..

BD251W 25 ..

BD251W 35 ..

BD251W 45 ..

BD250W 20 ..

BD250W 25 ..

BD250W 35 ..

BD250W 45 ..

BD351 20 ..

BD351 25 ..

BD351 35 ..

BD350 20 ..

BD350 25 ..

BD350 35 ..

BD351W 20 ..

BD351W 25 ..

BD351W 35 ..

BD350W 20 ..

BD350W 25 ..

BD350W 35 ..

BD251 20..

ESEMPIO DI CODICE PER VITI M8
EXAMPLE OF CODE FOR FIXING M8

pag. pag.

FINITURE FINISHES

- C Cromo lucido Bright Chrome
- T Cromo satinato Satin Chrome
- B Bronzo Bronze
- Z PVD Ottone PVD Brass
- TT Ottone satinato Satin Brass
- BS Bronzo satinato Satin Bronze
- IT Inox satinato Stainless steel

Ø50

PAT. PEND.

SFERIK

X ATRA

H	20	MA2365	MA2367
H	25	MA2871	MA2052
H	35	MA2053	MA2054
H	45	MA2685	

X ATRA

H	20	MA2365..	MA2367..
H	25	MA2871..	MA2052..
H	35	MA2053..	MA2054..
H	45	MA2685..	

A2209.. H 20
A1561.. H 25/35/45

FINITURE FINISHES

- C Cromo lucido Bright Chrome
- T Cromo satinato Satin Chrome
- B Bronzo Bronze
- Z PVD Ottone PVD Brass
- TT Ottone satinato Satin Brass
- BS Bronzo satinato Satin Bronze
- IT Inox satinato Stainless steel

pag. S1 D1

X ATRA pag. S1 D1

pag. pag.

BD201 20 ..

BD201 25 ..

BD201 35 ..

BD201 45 ..

BD200 20 ..

BD200 25 ..

BD200 35 ..

BD200 45 ..

BDT251W 20 ..

BDT251W 25 ..

BDT251W 35 ..

BDT251W 45 ..

BDT250W 20 ..

BDT250W 25 ..

BDT250W 35 ..

BDT250W 45 ..

BD301 20 ..

BD301 25 ..

BD301 35 ..

BD300 20 ..

BD300 25 ..

BD300 35 ..

BDT351W 20 ..

BDT351W 25 ..

BDT351W 35 ..

BDT350W 20 ..

BDT350W 25 ..

BDT350W 35 ..

BDT350W 45 ..

pag. pag.

FINITURE FINISHES

- C Cromo lucido Bright Chrome
- T Cromo satinato Satin Chrome
- B Bronzo Bronze
- Z PVD Ottone PVD Brass
- TT Ottone satinato Satin Brass
- BS Bronzo satinato Satin Bronze
- IT Inox satinato Stainless steel

Ø50

PAT. PEND.

SFERIK

X ATRA

H	25	MA3817	MA3818
---	----	--------	--------

X ATRA

H	25	MA3817..	MA3818..
---	----	----------	----------

A2209.. H 20
A1561.. H 25/35/45

FINITURE FINISHES

- C Cromo lucido Bright Chrome
- T Cromo satinato Satin Chrome
- B Bronzo Bronze
- Z PVD Ottone PVD Brass
- TT Ottone satinato Satin Brass
- BS Bronzo satinato Satin Bronze
- IT Inox satinato Stainless steel

pag. S1 D1

X ATRA pag. S1 D1

pag. pag.

BDF201 25 ..

BDF200 25 ..

BDF251W 25 ..

BDF250W 25 ..

BDF301 25 ..

BDF300 25 ..

BDF351W 25 ..

BDF350W 25 ..

pag. pag.

FINITURE FINISHES

- C Cromo lucido Bright Chrome
- T Cromo satinato Satin Chrome
- B Bronzo Bronze
- Z PVD Ottone PVD Brass
- TT Ottone satinato Satin Brass
- BS Bronzo satinato Satin Bronze
- IT Inox satinato Stainless steel

SUPER TOP

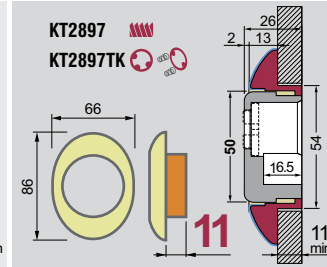
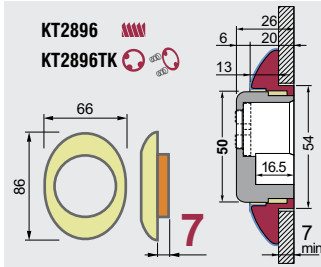

TOP

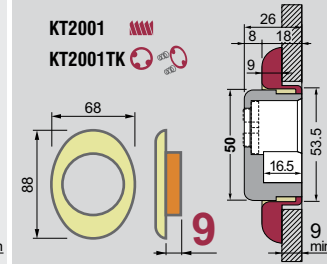
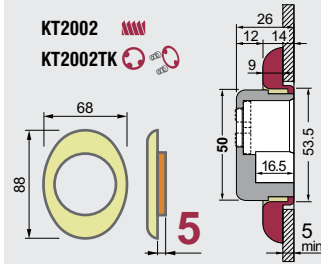

MONOLITO

OPTIONAL
A2073
SPESORE 5mm
SPACER 5mm
PAG

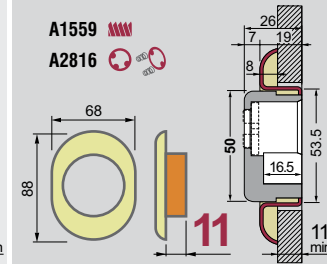
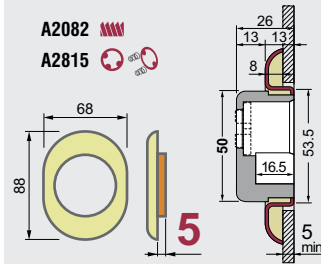

STONE

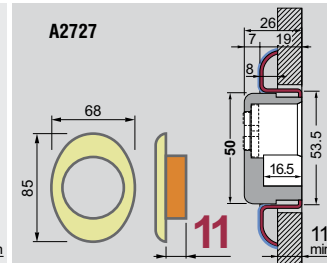
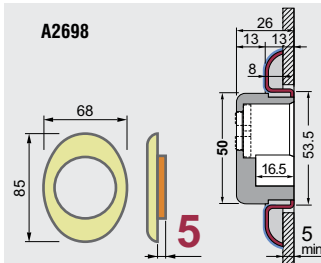

MILANO

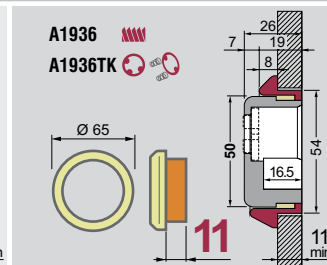
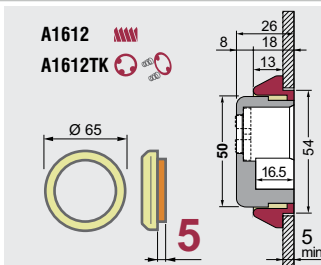

MONOLITO E

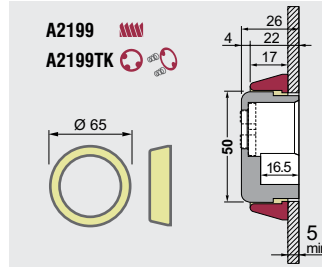

QUADRA

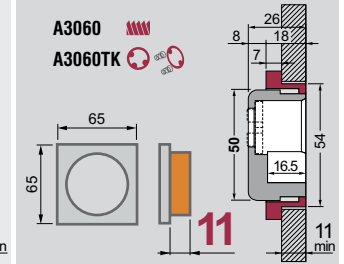
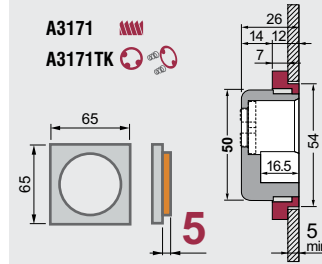

QUADRY

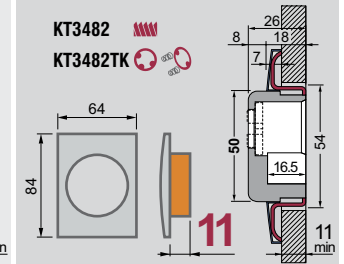
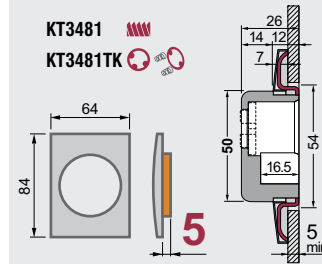

QUADRY P

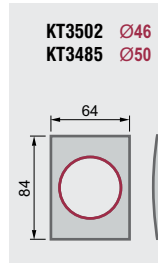

KUBO

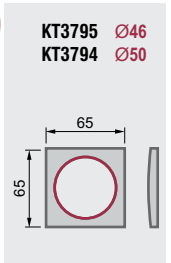

STANDARD

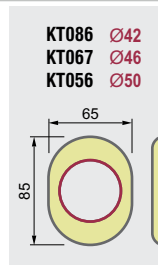

FILETTATO
Ø50

X OMEGA

FINITURE FINISHES

- C Cromo lucido Bright Chrome
- T Cromo satinato Satin Chrome
- B Bronzo Bronze
- Z PVD Ottone PVD Brass
- II Inox satinato Stainless steel

MA3086..

- C Cromo lucido Bright Chrome
- T Cromo satinato Satin Chrome
- B Bronzo Bronze
- Z PVD Ottone PVD Brass
- II Inox satinato Stainless steel

SUPER TOP 56x66

KT2896 h7
KT2897 h11

7 min

BD10800TB ..

BD10800TA ..

11 min

TOP 88x68

KT2002 h5
KT2001 h9

5 min

BD10800TB ..

BD10800TA ..

9 min

MONOLITO 88x68

A2082 h5
A1559 h11

5 min

BD10800TB ..

BD10800TA ..

11 min

BD10800B ..

BD10800A ..

MILANO Ø 65

A1612 h5
A1936 h11

5 min

BD10800MB ..

BD10800MA ..

11 min

MONOLITO E Ø 65

A2199

BD10800E ..

QUADRA 65x65

A3171 h5
A3060 h11

5 min

BD10800QB ..

BD10800QA ..

11 min

QUADRY 84x64

KT3481 h5
KT3482 h11

5 min

BD10800WB ..

BD10800WA ..

11 min

Ø50

X OMEGA

FINITURE FINISHES

- C Cromo lucido Bright Chrome
- T Cromo satinato Satin Chrome
- B Bronzo Bronze
- Z PVD Ottone PVD Brass
- II Inox satinato Stainless steel

MA3645..

A3375 2mm

PER TUTTE LE VERSIONI

INOX

BORDO ANTISTRAPPO

MONOLITO 88x68

A2815 h5
A2816 h11

5 min

BDF10800B ..

NNN

BDF10800A ..

11 min

QUADRA 65x65

A3171TK h5
A3060TK h11

5 min

BDF10800QB ..

NNN

BDF10800QA ..

11 min

QUADRY 84x64

KT3481TK h5
KT3482TK h11

5 min

BDF10800WB ..

NNN

BDF10800WA ..

11 min

RKD

ROK SFERIK

DIAMOND

PAT. PEND.



PAG



GRADO 4

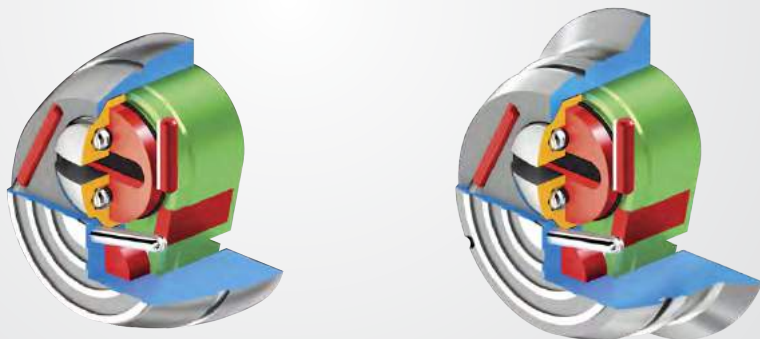
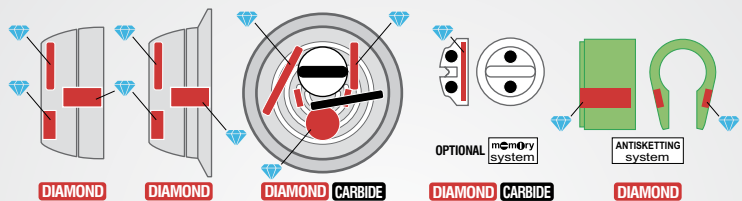

OPTIONAL
MEMORY SYSTEM

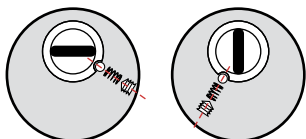

FLEX SYSTEM



RWS

ROK SFERIK

PAT. PEND.



PAG



GRADO 4

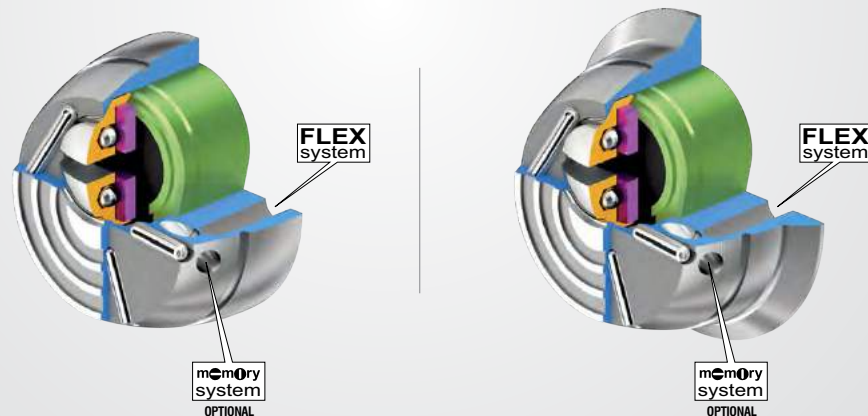
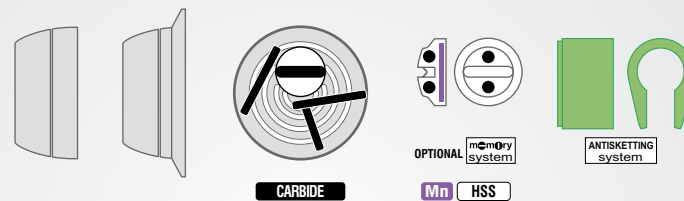

OPTIONAL
MEMORY SYSTEM

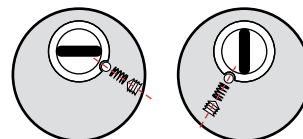

FLEX SYSTEM



RWS ROK



PAT. PEND.

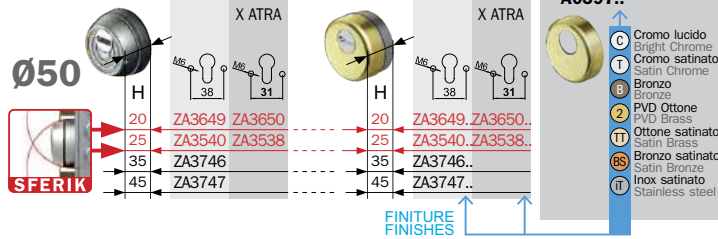

RWS16 20 .. P
RWS16 25 .. P
RWS16 35 .. P
RWS16 45 .. P

RWS16W 20 .. P
RWS16W 25 .. P
RWS16W 35 .. P
RWS16W 45 .. P

RWS16K 20 .. P
RWS16K 25 .. P
RWS16K 35 .. P
RWS16K 45 .. P

RWS68 20 .. P
RWS68 25 .. P

RWS68W 20 .. P
RWS68W 25 .. P

RWS68K 20 .. P
RWS68K 25 .. P

RWS16 8 25..

ESEMPIO CODICE

..
 ..
 ..

ESEMPIO DI CODICE PER VITI M8
 EXAMPLE OF CODE FOR VING M8



pag.

- FINITURE FINISHES**
- C Cromo lucido / Bright Chrome
 - T Cromo satinato / Satin Chrome
 - B Bronzo / Bronze
 - Z PVD Ottone / PVD Brass
 - TT Ottone satinato / Satin Brass
 - SS Bronzo satinato / Satin Bronze
 - IT Inox satinato / Stainless Steel

RWS ROK

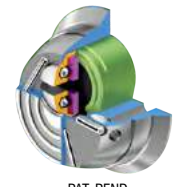

PAT. PEND.

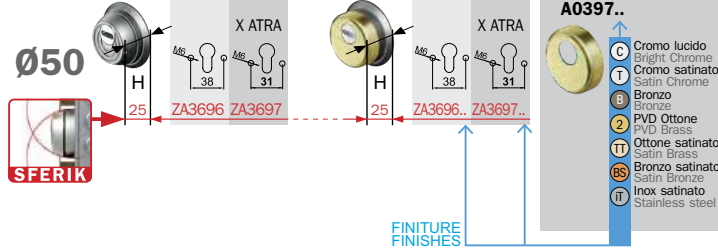

RWS42 25 .. P

RWS42W 25 .. P

RWS42K 25 .. P

RWS48 25 .. P

RWS48W 25 .. P

RWS48K 25 .. P

RWS42 8 25..

ESEMPIO CODICE

..

ESEMPIO DI CODICE PER VITI M8
 EXAMPLE OF CODE FOR VING M8



pag.

- FINITURE FINISHES**
- C Cromo lucido / Bright Chrome
 - T Cromo satinato / Satin Chrome
 - B Bronzo / Bronze
 - Z PVD Ottone / PVD Brass
 - TT Ottone satinato / Satin Brass
 - SS Bronzo satinato / Satin Bronze
 - IT Inox satinato / Stainless Steel

STONE ROK SFERIK

PAT. PEND.

memory system OPTIONAL
FLEX system



85x68



GRADO 4

PAG

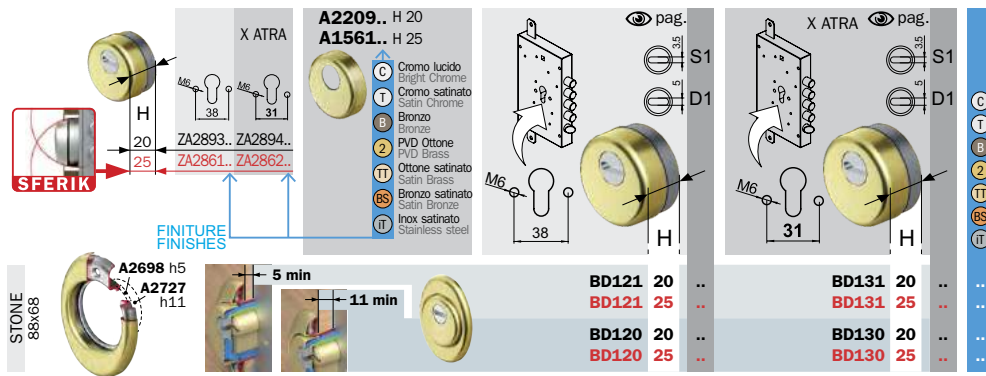
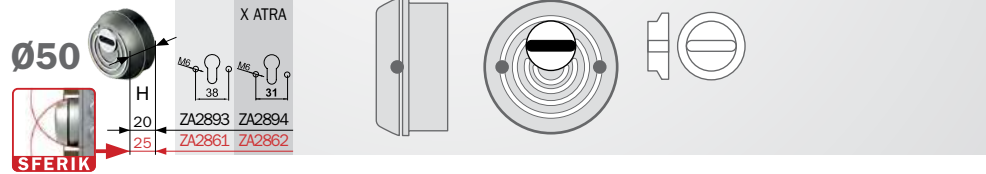
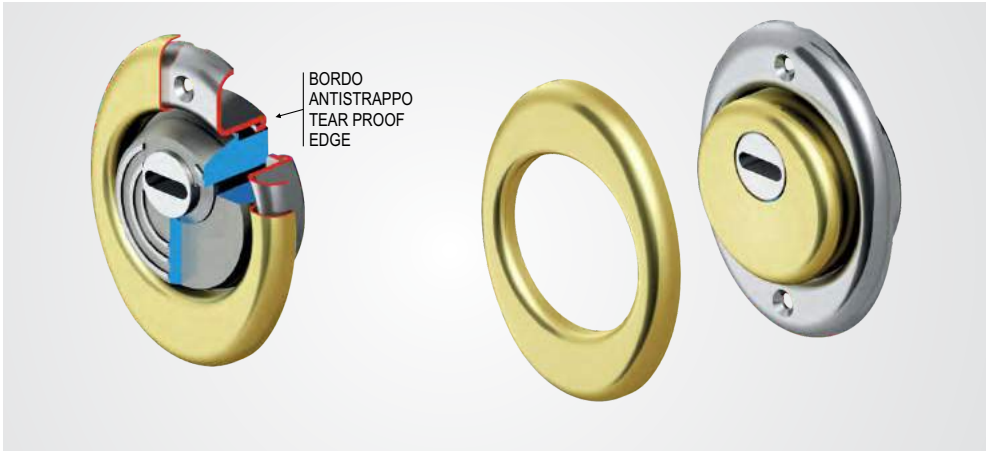

OPTIONAL
MEMORY SYSTEM

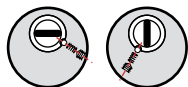

FLEX SYSTEM



5 VOLTE PIU' RESISTENTE DELLE VITI TRADIZIONALI 12.9

BDS ROK SFERIK

PAT. PEND.

memory system OPTIONAL
FLEX system

GRADO 4



PAG



RB ROK SFERIK

PAT. PEND.

memory system OPTIONAL
FLEX system

GRADO 4



PAG



OPTIONAL
MEMORY SYSTEM

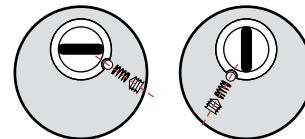

FLEX SYSTEM



5 VOLTE PIU' RESISTENTE DELLE VITI TRADIZIONALI 12.9

RB ROK



PAT. PEND.

Ø50



	X ATRA	X ATRA
25	ZA2384 ZA2458	ZA2384.. ZA2458..
35	ZA2632 ZA2127	ZA2632.. ZA2127..
45	ZA2126	ZA2126..
55	ZA2946	ZA2946..
65	ZA2947	ZA2947..
70	ZA2948 ZA2990	ZA2948.. ZA2990..

A0397..

C	Cromo lucido
T	Bright Chrome
S	Cromo satinato
S	Satin Chrome
B	Bronzo
2	PVD Ottono
2	PVD Brass
TT	Ottone satinato
TT	Satin Brass
BS	Bronzo satinato
BS	Satin Bronze
IT	Inox satinato
IT	Stainless steel

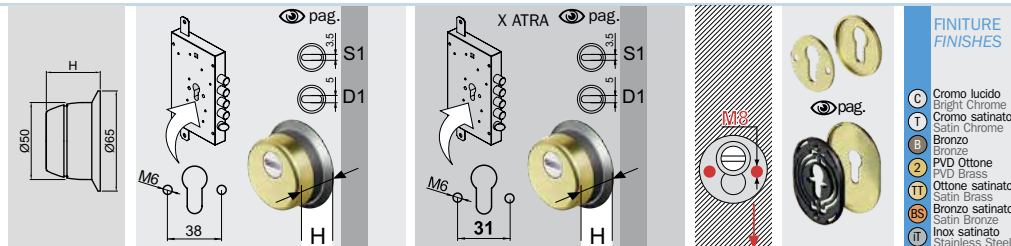

- FINITURE FINISHES**
- C Cromo lucido
 - T Bright Chrome
 - S Cromo satinato
 - S Satin Chrome
 - B Bronzo
 - 2 PVD Ottono
 - 2 PVD Brass
 - TT Ottone satinato
 - TT Satin Brass
 - BS Bronzo satinato
 - BS Satin Bronze
 - IT Inox satinato
 - IT Stainless Steel



	RBS42	25	..	P	RBS48	25	..	P	RBS42 8 25..	..
	RB42	35	..	P	RB48	35	..	P	ESEMPIO CODICE	..
	RB42	45	..	P					PER VITI M8	..
	RB42	55	..	P					EXAMPLE OF CODE FOR FINING M8	..
	RB42	65	..	P	RB48	70	..	P		..
	RB42	70	..	P						..
	RBS42W	25	..	P	RBS48W	25	..	P		..
	RB42W	35	..	P	RB48W	35	..	P		..
	RB42W	45	..	P						..
	RB42W	55	..	P						..
	RB42W	65	..	P	RB48W	70	..	P		..
	RB42W	70	..	P						..
	RBS42K	25	..	P	RBS48K	25	..	P		..
	RB42K	35	..	P	RB48K	35	..	P		..
	RB42K	45	..	P						..
	RB42K	55	..	P						..
	RB42K	65	..	P						..
	RB42K	70	..	P	RB48K	70	..	P		..

RBXPAS



Ø46

38	ZA1986	ZA1986..
48	ZA1987	ZA1987..
58	ZA1988	ZA1988..

A1663..

C	Cromo lucido
T	Bright Chrome
S	Cromo satinato
S	Satin Chrome
B	Bronzo
2	PVD Ottono
2	PVD Brass
TT	Ottone satinato
TT	Satin Brass
BS	Bronzo satinato
BS	Satin Bronze
IT	Inox satinato
IT	Stainless steel

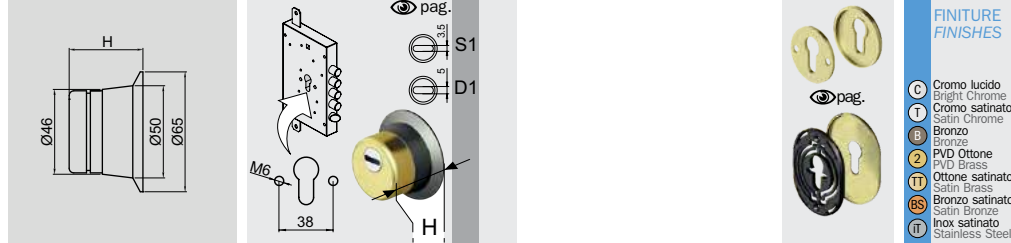

- FINITURE FINISHES**
- C Cromo lucido
 - T Bright Chrome
 - S Cromo satinato
 - S Satin Chrome
 - B Bronzo
 - 2 PVD Ottono
 - 2 PVD Brass
 - TT Ottone satinato
 - TT Satin Brass
 - BS Bronzo satinato
 - BS Satin Bronze
 - IT Inox satinato
 - IT Stainless Steel



	PAS	38	..	P						..
	PAS	48	..	P						..
	PAS	58	..	P						..
	PASW	38	..	P						..
	PASW	48	..	P						..
	PASW	58	..	P						..
	PASK	38	..	P						..
	PASK	48	..	P						..
	PASK	58	..	P						..



PAT. PEND.

Ø50

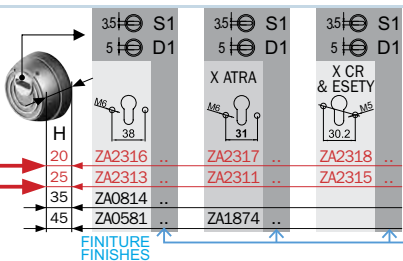

- A0397..
- C Cromo lucido Bright Chrome
 - T Cromo satinato Satin Chrome
 - B Bronzo Bronze
 - Z PVD Ottone PVD Brass
 - TT Ottone satinato Satin Brass
 - BS Bronzo satinato Satin Bronze
 - IT Inox satinato Stainless steel

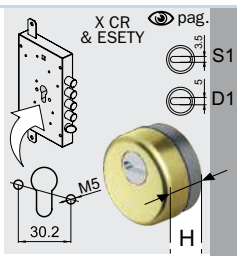
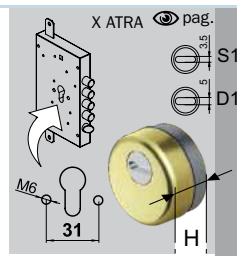
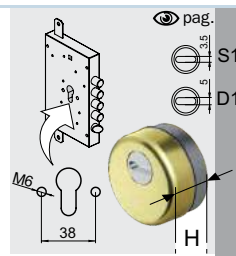

	BDS16 20 .. P BDS16 25 .. P BD16 35 .. P BD16 45 .. P		BDS68 20 .. P BDS68 25 .. P BD68 45 .. P	BDS16 8 20.. ESEMPIO CODICE	BDS61 20 .. P BDS61 25 .. P	pag. KT029
	BDS16 20 .. PP BDS16 25 .. PP BD16 35 .. PP BD16 45 .. PP		BDS68 20 .. PP BDS68 25 .. PP BD68 45 .. PP	EXAMPLE OF CODE FOR FIXING M8	BDS61 20 .. PP BDS61 25 .. PP	
	BDS16 20 .. BDS16 25 .. BD16 35 .. BD16 45 ..		BDS68 20 .. BDS68 25 .. BD68 45 ..		BDS61 20 .. BDS61 25 ..	
	BDS16 20 .. M BDS16 25 .. M BD16 35 .. M BD16 45 .. M		BDS68 20 .. M BDS68 25 .. M BD68 45 .. M		BDS61 20 .. M BDS61 25 .. M	
	BDS16 20 .. W BDS16 25 .. W BD16 35 .. W BD16 45 .. W		BDS68 20 .. W BDS68 25 .. W BD68 45 .. W	ESEMPIO DI CODICE PER VITI M8	BDS61 20 .. W BDS61 25 .. W	pag.
	BDS16 20 .. WP BDS16 25 .. WP BD16 35 .. WP BD16 45 .. WP		BDS68 20 .. WP BDS68 25 .. WP BD68 45 .. WP		BDS61 20 .. WP BDS61 25 .. WP	
	BDS16 20 .. K BDS16 25 .. K BD16 35 .. K BD16 45 .. K		BDS68 20 .. K BDS68 25 .. K BD68 45 .. K		BDS61 20 .. K BDS61 25 .. K	pag.

X FIAM



Ø46

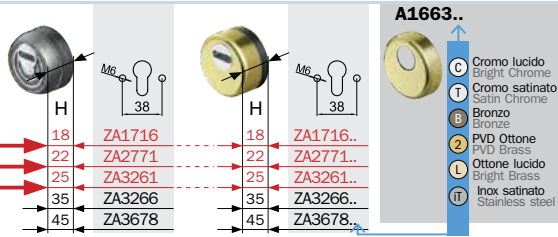

	Ø46			
	Ø46			
	Ø46			

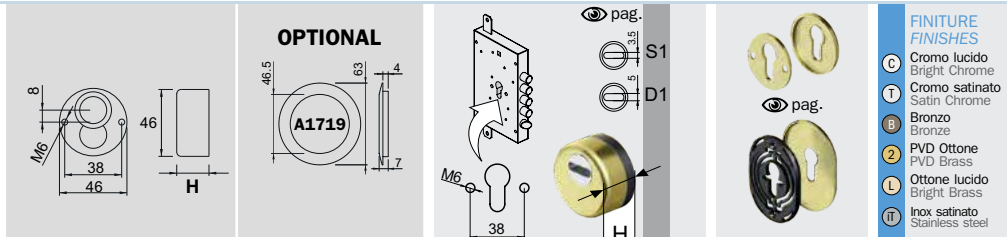

BDS57	18	..	P	..
BDS57	22	..	P	..
BDS57	25	..	P	..
BD57	35	..	P	..
BD57	45	..	P	..

BDS57W	18
BDS57W	22
BDS57W	25
BD57W	35
BD57W	45

BDS57K	18
BDS57K	22
BDS57K	25
BD57K	35
BD57K	45

- FINITURE FINISHES**
- C Cromo lucido Bright Chrome
 - T Cromo satinato Satin Chrome
 - B Bronzo Bronze
 - 2 PVD Ottone PVD Brass
 - L Ottone lucido Bright Brass
 - IT Inox satinato Stainless steel



Ø50

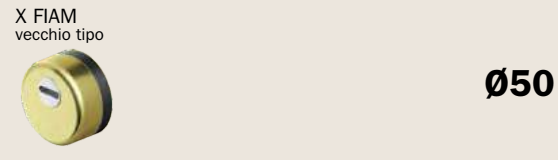

BD55	25
------	----	----	----	----

X FIAM



Ø46

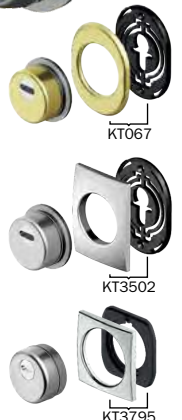
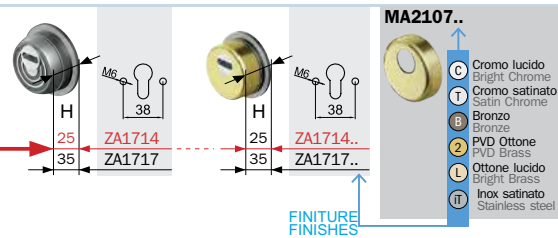

	Ø46			
	Ø46			
	Ø46			

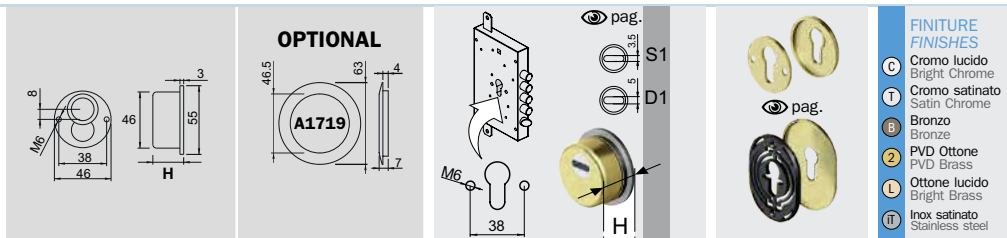

BDS80	25	..	P	..
BD81	35	..	P	..

BDS80W	25
BD81W	35

BDS80K	25
BD81K	35

- FINITURE FINISHES**
- C Cromo lucido Bright Chrome
 - T Cromo satinato Satin Chrome
 - B Bronzo Bronze
 - 2 PVD Ottone PVD Brass
 - L Ottone lucido Bright Brass
 - IT Inox satinato Stainless steel



Ø42

SFERIK

X ATRA X CR & ESETY X ESETY

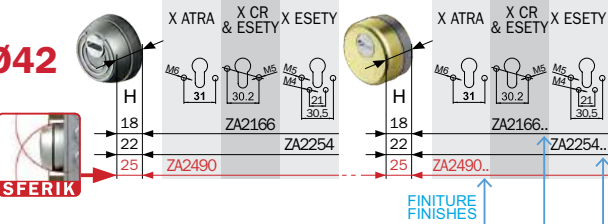

ZA2166 ZA2254 ZA2490 ZA2254..

A0397..

- C Cromo lucido / Bright Chrome
- T Cromo satinato / Satin Chrome
- B Bronzo / Bronze
- 2 PVD Ottonne / PVD Brass
- TT Ottonne satinato / Satin Brass
- BS Bronzo satinato / Satin Bronze
- IT Inox satinato / Stainless steel

X ATRA pag. S1 D1

X CR & ESETY pag. S1 D1

X ESETY pag. S1 D1

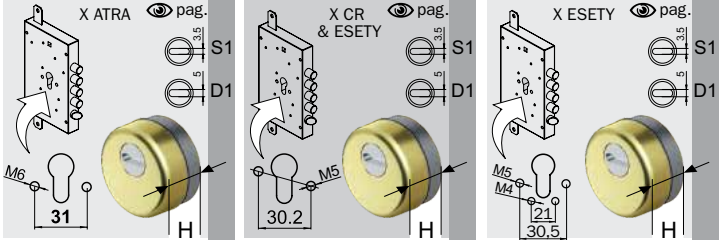

FINITURE FINISHES

- C Cromo lucido / Bright Chrome
- T Cromo satinato / Satin Chrome
- B Bronzo / Bronze
- 2 PVD Ottonne / PVD Brass
- TT Ottonne satinato / Satin Brass
- BS Bronzo satinato / Satin Bronze
- IT Inox satinato / Stainless Steel



KT086



Ø42

BDS74 25 ..

BD35 18 ..

BD87 22 ..

Kit **KT500** (X BDS35..P)



BDS35..P

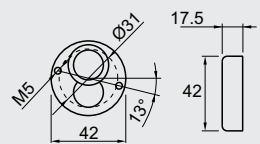

Ø31 17.5 42 M5 13°

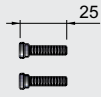

A0412-5025 TOT. 2 PZ



A1063 1mm A1056 2mm

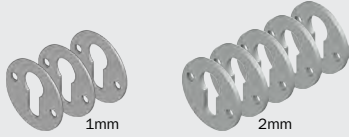

A1063 1mm A1056 2mm TOT. 3 PZ

VITI/SCREW OPTIONAL



L=16 A0412 L=25 A0412-5025 L=70 A0412-5070 L=100 A0412-50100

X CR



Ø42

X CR

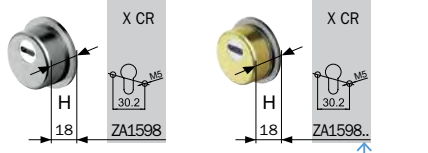

ZA1598

A0397..

- 1 Cromo satinato / Satin Chrome
- 2 PVD Ottonne / PVD Brass

X CR pag. S1 D1

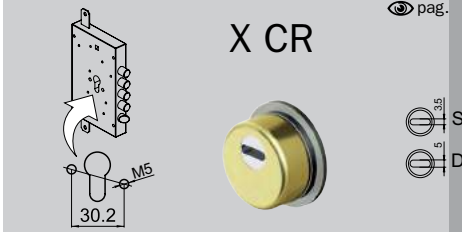

FINITURE FINISHES

- C Cromo lucido / Bright Chrome
- T Cromo satinato / Satin Chrome
- B Bronzo / Bronze
- 2 PVD Ottonne / PVD Brass
- TT Ottonne satinato / Satin Brass
- BS Bronzo satinato / Satin Bronze
- IT Inox satinato / Stainless Steel



KT086



Ø42

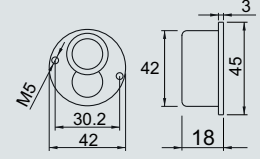

M5 42 18 45 3

BD96 ..

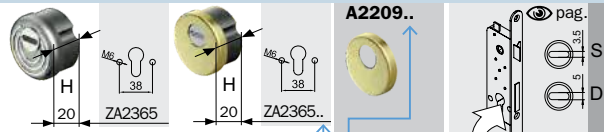

FINITURE FINISHES

- C** Cromo lucido
Bright Chrome
- T** Cromo satinato
Satin Chrome
- B** Bronzo
Bronze
- Z** PVD Ottono
PVD Brass
- IT** Inox satinato
Stainless steel

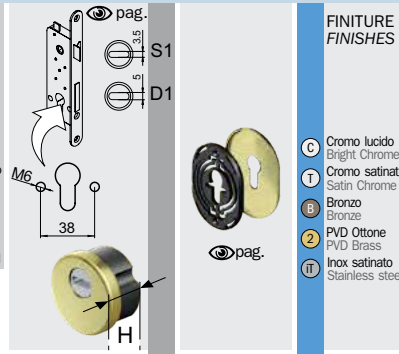

FINITURE FINISHES

- C** Cromo lucido
Bright Chrome
- T** Cromo satinato
Satin Chrome
- B** Bronzo
Bronze
- Z** PVD Ottono
PVD Brass
- IT** Inox satinato
Stainless steel

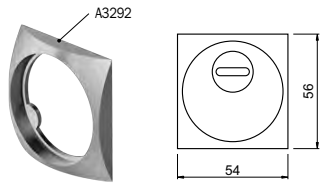

BD28Q 20



KT002

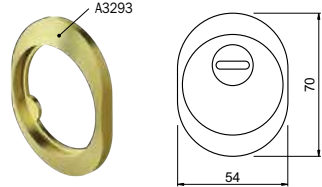

BD28C 20



KT029

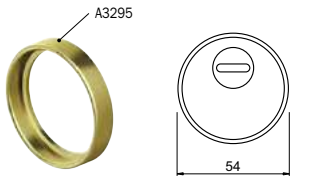

BD28F 20

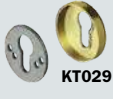

KT029

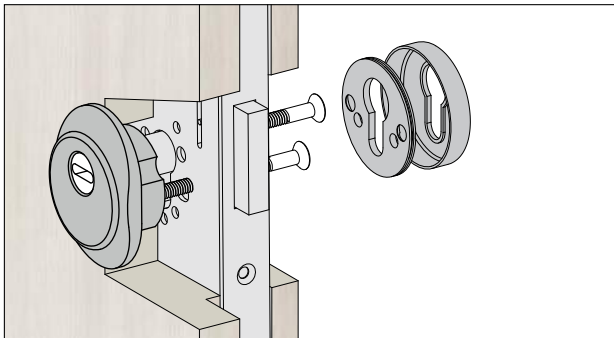

- C** Cromo lucido
Bright Chrome
- Z** PVD Ottono
PVD Brass
- IT** Inox satinato
Stainless steel
- T** Cromo satinato
Satin Chrome
- TT** Ottono satinato
Satin Brass
- N** Nero
Black
- B** Bronzo
Bronze
- BS** Bronzo satinato
Satin Bronze

X VIGHI



VD15

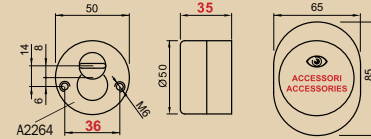

Ø50

X VIGHI

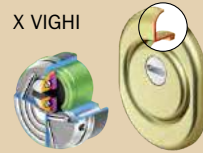

VD20A

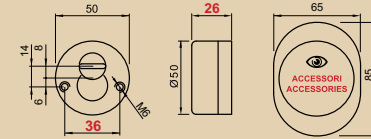

Ø50

X VIGHI



VD14

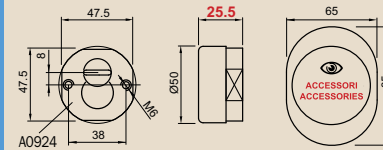

Ø50

X POTENT



BD8932

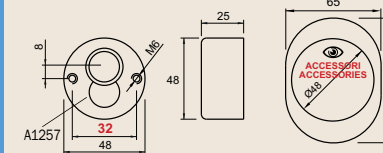

Ø48

X POTENT



BD89

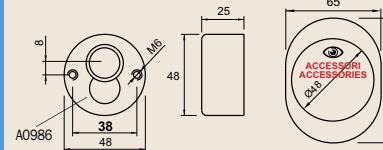

Ø48

X ESETY
Multilock

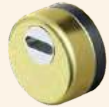

ZA2040

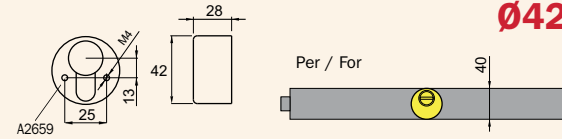

Ø42

X ESETY
Multilock



BD92

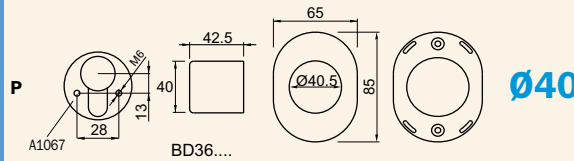

Ø40

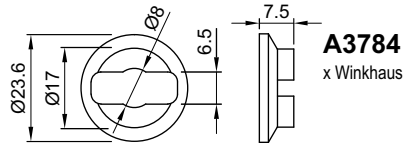
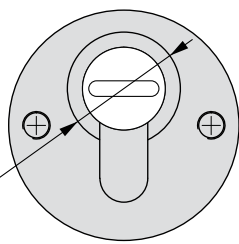

A3784
x Winkhaus

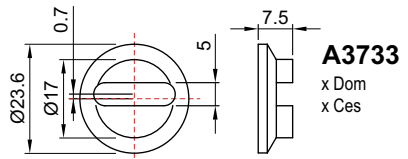

A3733
x Dom
x Ces

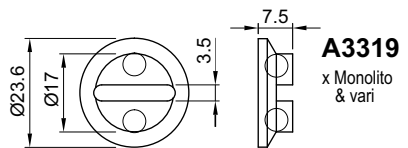

A3319
x Monolito
& vari

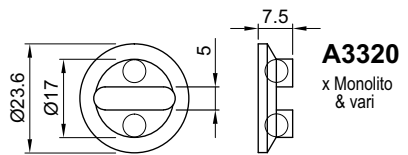

A3320
x Monolito
& vari

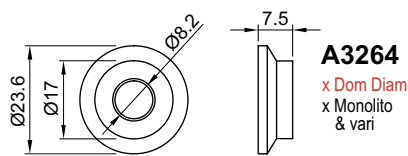

A3264
x Dom Diamant
x Monolito
& vari

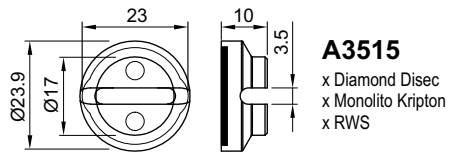

A3515
x Diamond Disec
x Monolito Krypton
x RWS

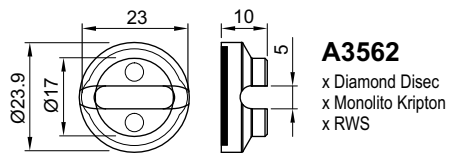

A3562
x Diamond Disec
x Monolito Krypton
x RWS

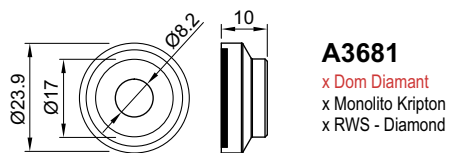

A3681
x Dom Diamant
x Monolito Krypton
x RWS - Diamond

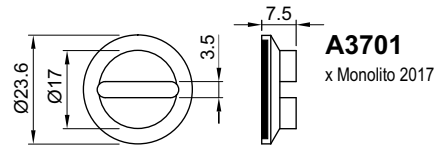

A3701
x Monolito 2017

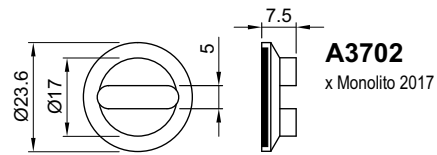

A3702
x Monolito 2017

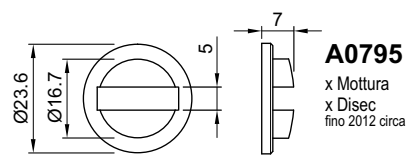

A0795
x Mottura
x Disec
fino 2012 circa

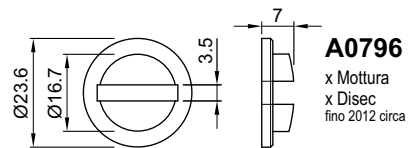

A0796
x Mottura
x Disec
fino 2012 circa

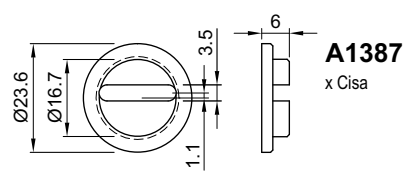

A1387
x Cisa

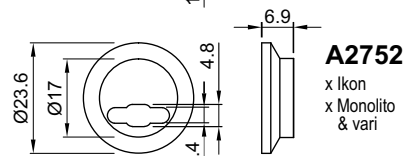

A2752
x Ikon
x Monolito
& vari

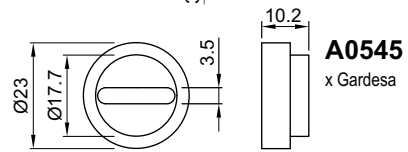

A0545
x Gardesa

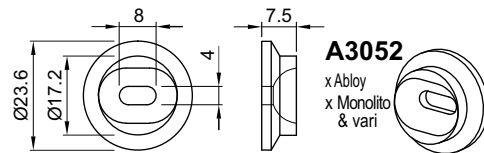

A3052
x Abloy
x Monolito
& vari

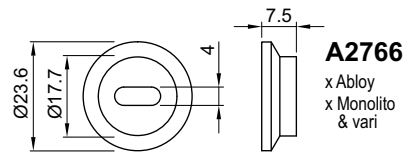

A2766
x Abloy
x Monolito
& vari

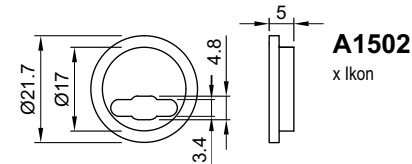
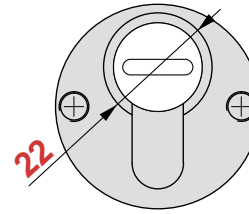

A1502
x Ikon

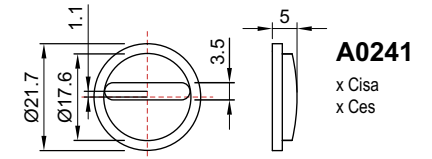

A0241
x Cisa
x Ces

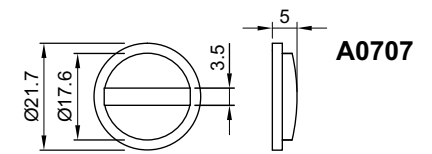

A0707

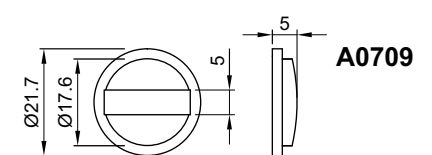

A0709

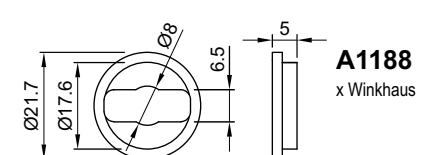

A1188
x Winkhaus

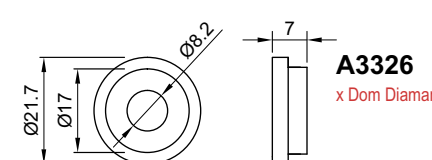

A3326
x Dom Diamant

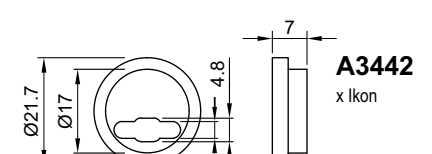

A3442
x Ikon

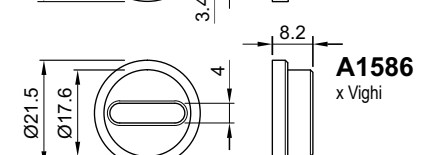

A1586
x Vighi

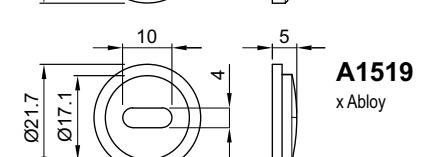

A1519
x Abloy

MAG4G

PAT. PEND.



KMOP47

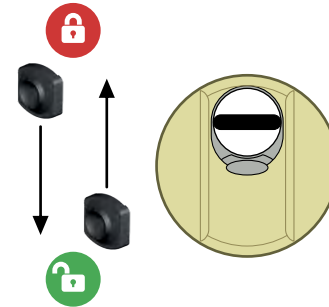
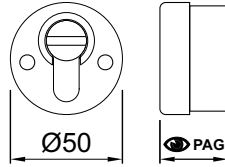
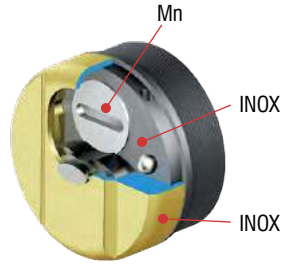

MAG3G

PAT. PEND.



KMOP3G

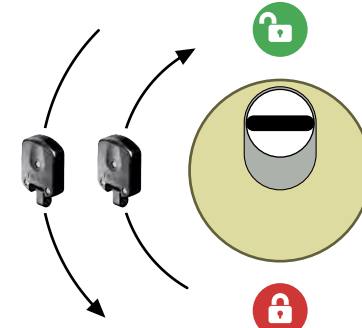
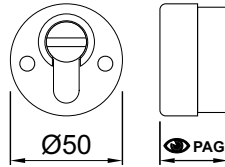
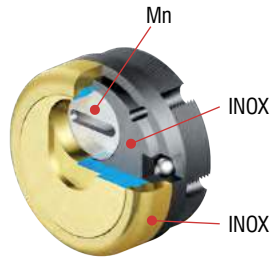

MRM23

PAT. PEND.



KMOP46

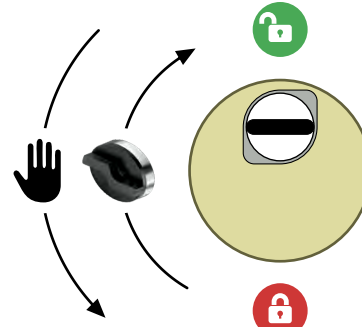
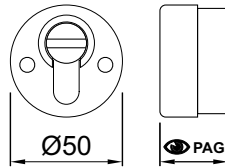
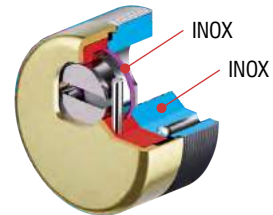
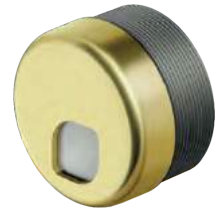

MAG ROUND

PAT. PEND.



KMOP42

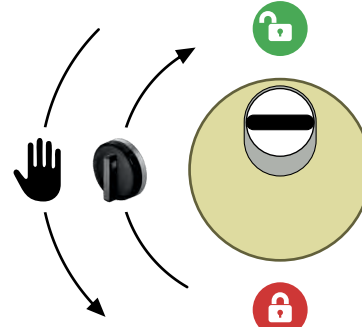
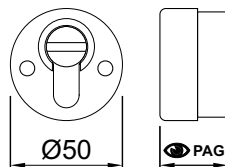
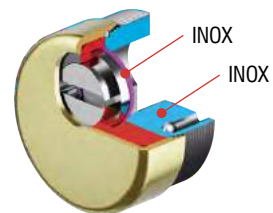

SUPER TOP
86x66



TOP
88x68



MONOLITO
88x68



MILANO
Ø 65



MONOLITO E
Ø 65



QUADRA
65x65



QUADRY
84x64



FILETTATO
Ø50

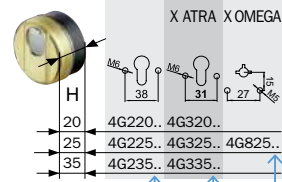

FINITURE FINISHES
C Cromo lucido Bright Chrome
T Cromo satinato Satin Chrome
2 PVD Ottone PVD Brass
IT Inox satinato Stainless steel

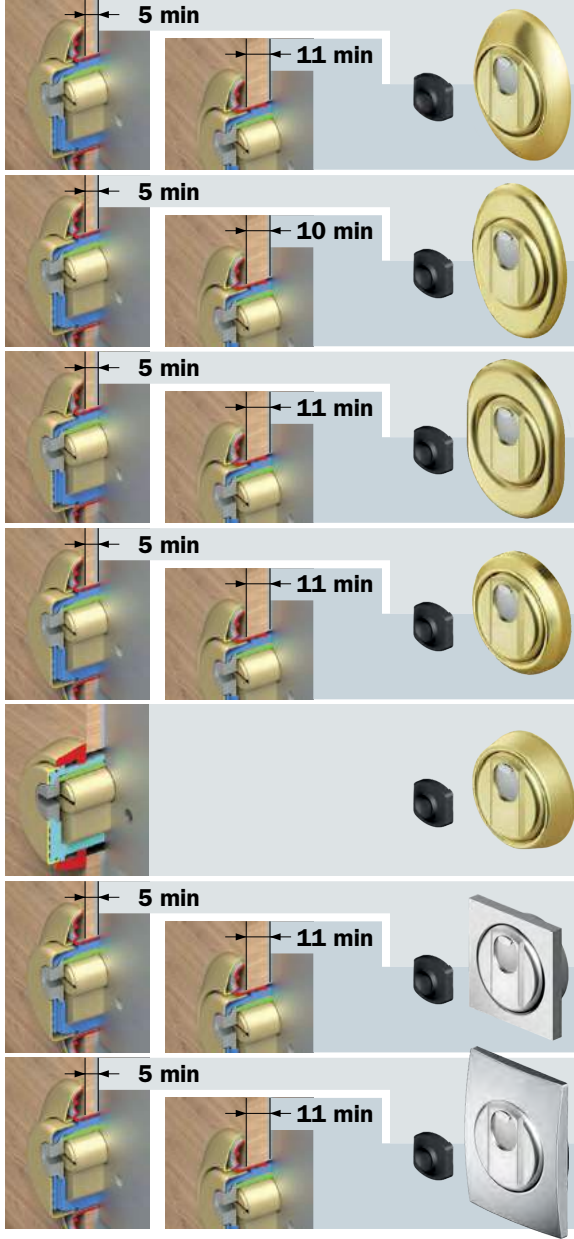
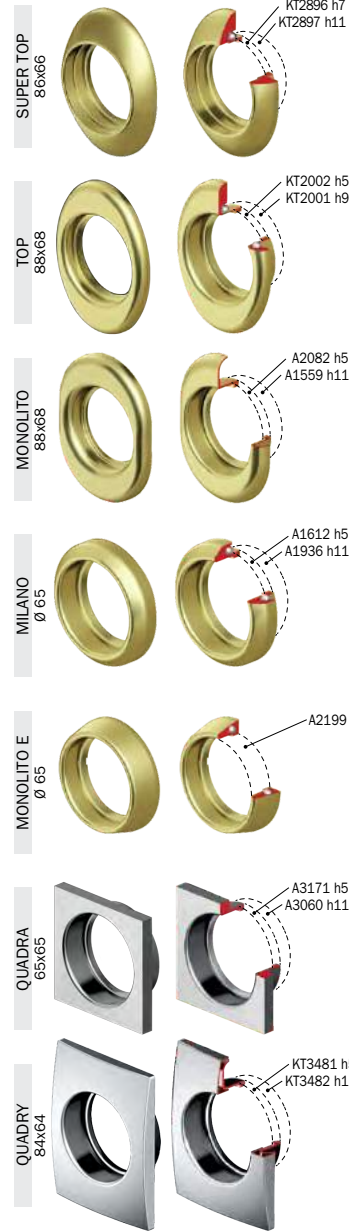
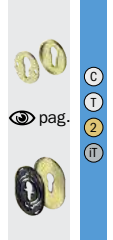
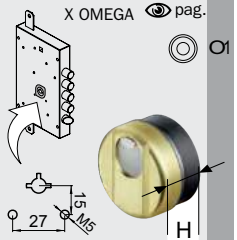
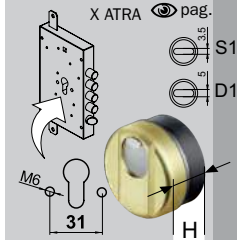
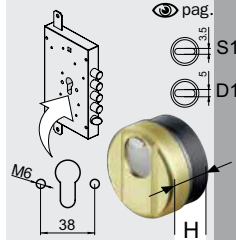

4G2STB 20	..	4G3STB 20	..	4G2STB 8 20..	..	4G8STB 25	O1
4G2STB 25	..	4G3STB 25	4G8ST 25	O1
4G2STB 35	..	4G3STB 35
4G2ST 20	..	4G3ST 20
4G2ST 25	..	4G3ST 25
4G2ST 35	..	4G3ST 35
4G2TB 20	..	4G3TB 20
4G2TB 25	..	4G3TB 25
4G2TB 35	..	4G3TB 35
4G2T 20	..	4G3T 20
4G2T 25	..	4G3T 25
4G2T 35	..	4G3T 35
4G2MB 20	..	4G3MB 20
4G2MB 25	..	4G3MB 25
4G2MB 35	..	4G3MB 35
4G2M 20	..	4G3M 20
4G2M 25	..	4G3M 25
4G2M 35	..	4G3M 35
4G2MMB 20	..	4G3MMB 20
4G2MMB 25	..	4G3MMB 25
4G2MMB 35	..	4G3MMB 35
4G2MM 20	..	4G3MM 20
4G2MM 25	..	4G3MM 25
4G2MM 35	..	4G3MM 35
4G2EB 20	..	4G3EB 20
4G2EB 25	..	4G3EB 25
4G2EB 35	..	4G3EB 35
4G2QB 20	..	4G3QB 20
4G2QB 25	..	4G3QB 25
4G2QB 35	..	4G3QB 35
4G2Q 20	..	4G3Q 20
4G2Q 25	..	4G3Q 25
4G2Q 35	..	4G3Q 35
4G2WB 20	..	4G3WB 20
4G2WB 25	..	4G3WB 25
4G2WB 35	..	4G3WB 35
4G2W 20	..	4G3W 20
4G2W 25	..	4G3W 25
4G2W 35	..	4G3W 35

EXAMPLE OF CODE FOR FIXING M8

ESEMPIO DI CODICE PER VITI M8

FILETTATO
Ø50

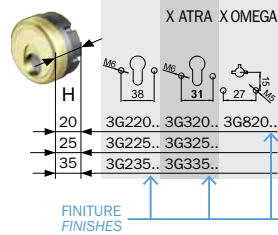

- FINITURE FINISHES
- C Cromo lucido Bright Chrome
 - S Cromo satinato Satin Chrome
 - 2 PVD Ottone PVD Brass
 - IT Inox satinato Stainless steel

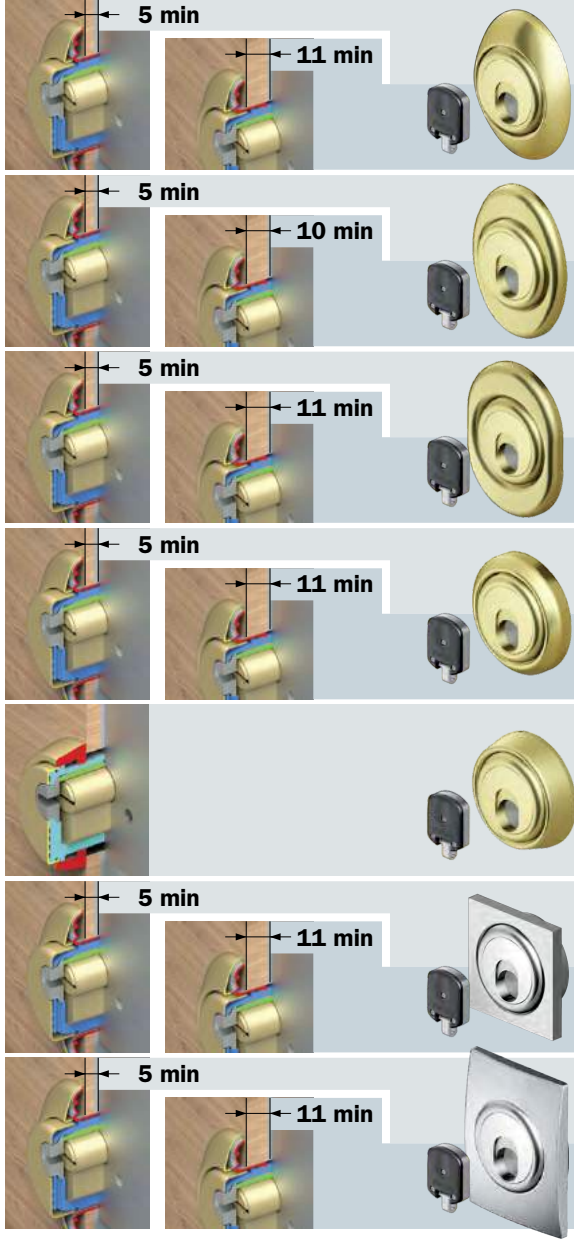
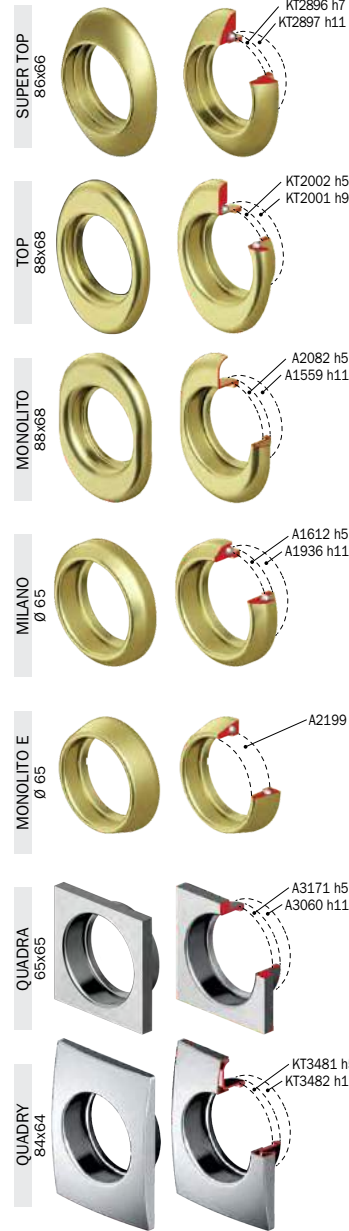

3G2STB 20	..	3G3STB 20	..	3G2STB 8 20..	3G8STB 20	O1	..
3G2STB 25	..	3G3STB 25
3G2STB 35	..	3G3STB 35
3G2ST 20	..	3G3ST 20	..		3G8ST 20	O1	..
3G2ST 25	..	3G3ST 25
3G2ST 35	..	3G3ST 35
3G2TB 20	..	3G3TB 20	..		3G8TB 20	O1	..
3G2TB 25	..	3G3TB 25
3G2TB 35	..	3G3TB 35
3G2T 20	..	3G3T 20	..		3G8T 20	O1	..
3G2T 25	..	3G3T 25
3G2T 35	..	3G3T 35
3G2MB 20	..	3G3MB 20	..		3G8MB 20	O1	..
3G2MB 25	..	3G3MB 25
3G2MB 35	..	3G3MB 35
3G2M 20	..	3G3M 20	..		3G8M 20	O1	..
3G2M 25	..	3G3M 25
3G2M 35	..	3G3M 35
3G2MMB 20	..	3G3MMB 20	..		3G8MMB 20	O1	..
3G2MMB 25	..	3G3MMB 25
3G2MMB 35	..	3G3MMB 35
3G2MM 20	..	3G3MM 20	..		3G8MM 20	O1	..
3G2MM 25	..	3G3MM 25
3G2MM 35	..	3G3MM 35
3G2EB 20	..	3G3EB 20	..		3G8EB 20	O1	..
3G2EB 25	..	3G3EB 25
3G2EB 35	..	3G3EB 35
3G2QB 20	..	3G3QB 20	..		3G8QB 20	O1	..
3G2QB 25	..	3G3QB 25
3G2QB 35	..	3G3QB 35
3G2Q 20	..	3G3Q 20	..		3G8Q 20	O1	..
3G2Q 25	..	3G3Q 25
3G2Q 35	..	3G3Q 35
3G2WB 20	..	3G3WB 20	..		3G8WB 20	O1	..
3G2WB 25	..	3G3WB 25
3G2WB 35	..	3G3WB 35
3G2W 20	..	3G3W 20	..		3G8W 20	O1	..
3G2W 25	..	3G3W 25
3G2W 35	..	3G3W 35

ESEMPIO DI CODICE PER VITI M8

ESEMPIO CODICE



SUPER TOP
56x66

TOP
88x68

MONOLITO
88x68

MILANO
Ø 65

MONOLITO E
Ø 65

QUADRA
65x65

QUADRY
84x64

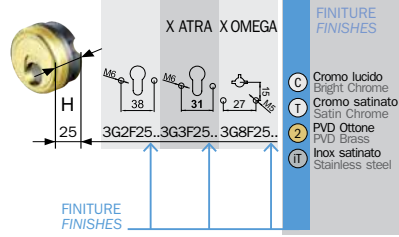

- FINITURE FINISHES**
- C Cromo lucido / Bright Chrome
 - T Cromo satinato / Satin Chrome
 - 2 PVD Ottone / PVD Brass
 - IT Inox satinato / Stainless steel

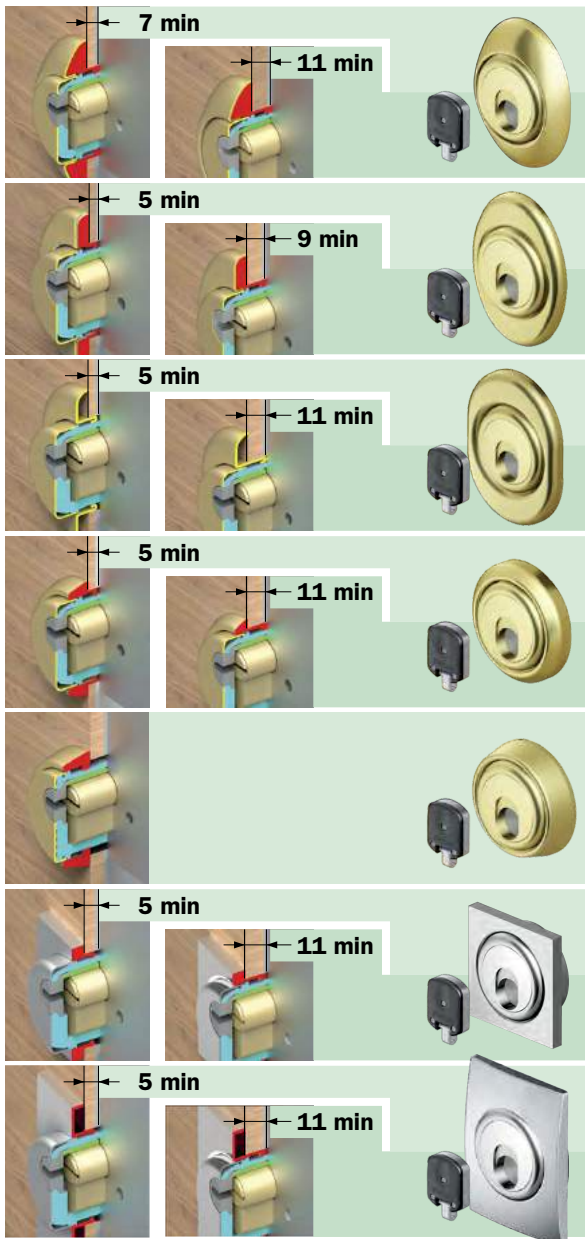
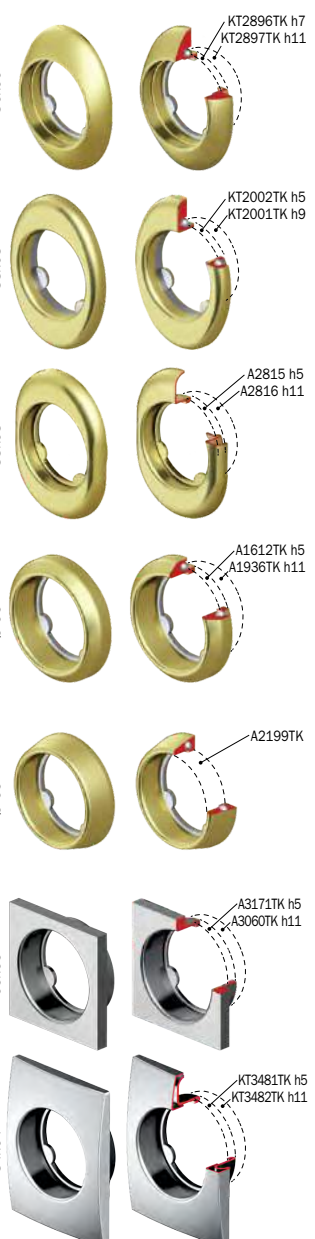
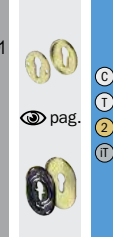
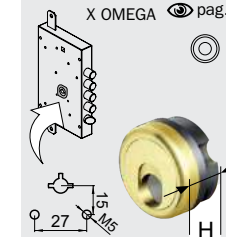
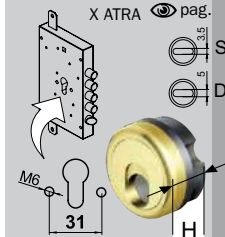
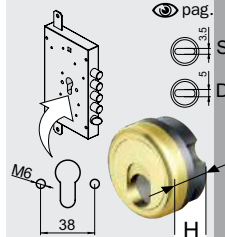

3G2STBF	25	..	3G3STBF	25	..	3G8STBF	25	O1
3G2STF	25	..	3G3STF	25	..	3G8STF	25	O1
3G2TBF	25	..	3G3TBF	25	..	3G8TBF	25	O1
3G2TF	25	..	3G3TF	25	..	3G8TF	25	O1
3G2MBF	25	..	3G3MBF	25	..	3G8MBF	25	O1
3G2MF	25	..	3G3MF	25	..	3G8MF	25	O1
3G2MMBF	25	..	3G3MMBF	25	..	3G8MMBF	25	O1
3G2MMF	25	..	3G3MMF	25	..	3G8MMF	25	O1
3G2EBF	25	..	3G3EBF	25	..	3G8EBF	25	O1
3G2QBF	25	..	3G3QBF	25	..	3G8QBF	25	O1
3G2QF	25	..	3G3QF	25	..	3G8QF	25	O1
3G2WBF	25	..	3G3WBF	25	..	3G8WBF	25	O1
3G2WF	25	..	3G3WF	25	..	3G8WF	25	O1

MAG 4G

4G

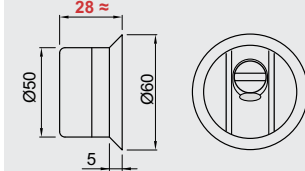
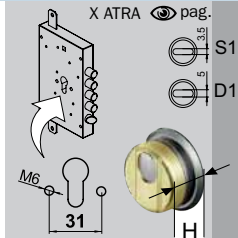
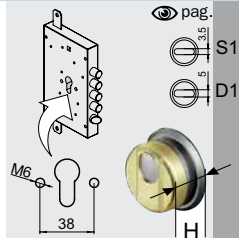
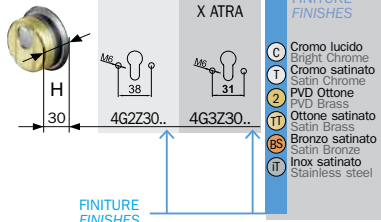

- FINITURE FINISHES
- C Cromo lucido / Bright Chrome
 - T Cromo satinato / Satin Chrome
 - 2 PVD Ottonne / PVD Brass
 - TT Ottonne satinato / Satin Brass
 - BS Bronzo satinato / Satin Bronze
 - IT Inox satinato / Stainless steel



4G2Z 30 .. P

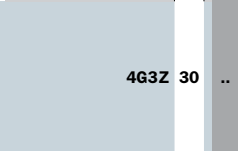

4G3Z 30 .. P



4G2ZW 30 .. P

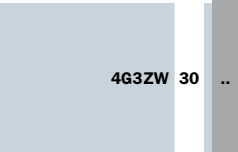

4G3ZW 30 .. P

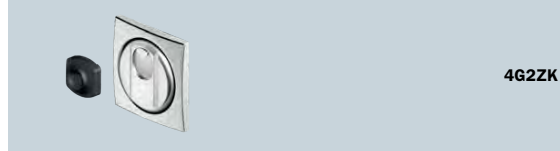

4G2ZK 30 .. P



4G3ZK 30 .. P

4G2Z 8 20..
ESEMPIO CODICE

ESEMPIO DI CODICE PER VITI M8
EXAMPLE OF CODE FOR FIXING M8

- pag.
- C Cromo lucido / Bright Chrome
 - T Cromo satinato / Satin Chrome
 - 2 PVD Ottonne / PVD Brass
 - IT Inox satinato / Stainless steel

MAG 3G

3G

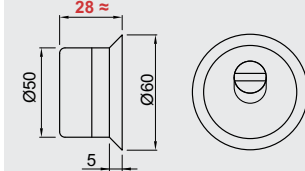
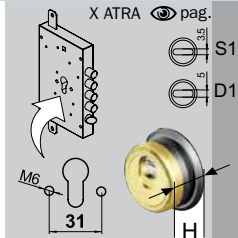
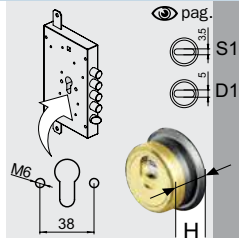
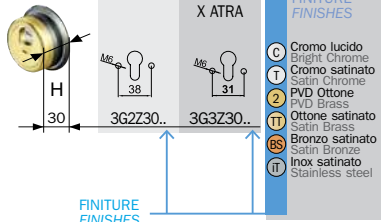

- FINITURE FINISHES
- C Cromo lucido / Bright Chrome
 - T Cromo satinato / Satin Chrome
 - 2 PVD Ottonne / PVD Brass
 - TT Ottonne satinato / Satin Brass
 - BS Bronzo satinato / Satin Bronze
 - IT Inox satinato / Stainless steel

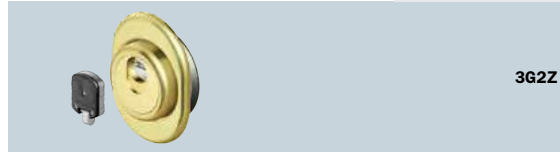

3G2Z 30 .. P

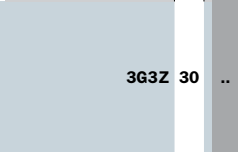

3G3Z 30 .. P



3G2ZW 30 .. P

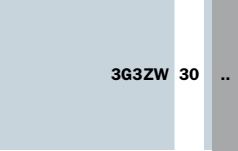

3G3ZW 30 .. P



4G2ZK 30 .. P

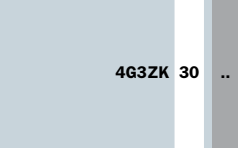

4G3ZK 30 .. P

3G2Z 8 20
ESEMPIO CODICE

ESEMPIO DI CODICE PER VITI M8
EXAMPLE OF CODE FOR FIXING M8

- pag.
- C Cromo lucido / Bright Chrome
 - T Cromo satinato / Satin Chrome
 - 2 PVD Ottonne / PVD Brass
 - IT Inox satinato / Stainless steel

FILETTATO
Ø50

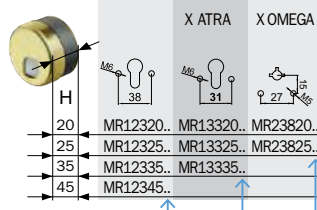

- X ATRA X OMEGA
- FINITURE FINISHES
- C Cromo lucido / Bright Chrome
 - T Cromo satinato / Satin Chrome
 - B Bronzo / Bronze
 - Z PVD Ottone / PVD Brass
 - TI Ottone satinato / Satin Brass
 - BS Bronzo satinato / Satin Bronze
 - IT Inox satinato / Stainless steel

SUPER TOP
56x66

TOP
88x68

MONOLITO
88x68

MILANO
Ø 65

MONOLITO E
Ø 65

QUADRA
65x65

QUADRY
84x64



7 min	11 min		MRSTB23 20	MRSTB33 20	MRSTB23 8 20..	MRSTB103 20
			MRSTB23 25	MRSTB33 25		MRSTB103 25
			MRSTB23 35	MRSTB33 35		
			MRSTB23 45	MRSTB33 35		
			MRSTA23 20	MRSTA33 20		MRSTA103 20
			MRSTA23 25	MRSTA33 25		MRSTA103 25
			MRSTA23 35	MRSTA33 35		
			MRSTA23 45	MRSTA33 35		
5 min	9 min		MRTB23 20	MRTB33 20		MRTB103 20
			MRTB23 25	MRTB33 25		MRTB103 25
			MRTB23 35	MRTB33 35		
			MRTB23 45	MRTB33 35		
			MRTA23 20	MRTA33 20		MRTA103 20
			MRTA23 25	MRTA33 25		MRTA103 25
			MRTA23 35	MRTA33 35		
			MRTA23 45	MRTA33 35		
5 min	11 min		MRM23B 20	MRM33B 20		MRM103B 20
			MRM23B 25	MRM33B 25		MRM103B 25
			MRM23B 35	MRM33B 35		
			MRM23B 45	MRM33B 35		
			MRM23 20	MRM33 20		MRM103A 20
			MRM23 25	MRM33 25		MRM103A 25
			MRM23 35	MRM33 35		
			MRM23 45	MRM33 35		
5 min	11 min		MRM23MB 20	MRM33MB 20		MRM103MB 20
			MRM23MB 25	MRM33MB 25		MRM103MB 25
			MRM23MB 35	MRM33MB 35		
			MRM23MB 45	MRM33MB 35		
			MRM23MA 20	MRM33MA 20		MRM103MA 20
			MRM23MA 25	MRM33MA 25		MRM103MA 25
			MRM23MA 35	MRM33MA 35		
			MRM23MA 45	MRM33MA 35		
			MRME23 20	MRME33 20		MRE103 20
			MRME23 25	MRME33 25		MRE103 25
			MRME23 35	MRME33 35		
			MRME23 45	MRME33 35		
5 min	11 min		MRQA23 20	MRQA33 20		MRQA103 20
			MRQA23 25	MRQA33 25		MRQA103 25
			MRQA23 35	MRQA33 35		
			MRQA23 45	MRQA33 35		
			MRQB23 20	MRQB33 20		MRQB103 20
			MRQB23 25	MRQB33 25		MRQB103 25
			MRQB23 35	MRQB33 35		
			MRQB23 45	MRQB33 35		
5 min	11 min		MRWA23 20	MRWA33 20		MRWA103 20
			MRWA23 25	MRWA33 25		MRWA103 25
			MRWA23 35	MRWA33 35		
			MRWA23 45	MRWA33 35		
			MRWB23 20	MRWB33 20		MRWB103 20
			MRWB23 25	MRWB33 25		MRWB103 25
			MRWB23 35	MRWB33 35		
			MRWB23 45	MRWB33 35		

ESEMPIO DI CODICE FOR FIXING M8

ESEMPIO DI CODICE PER VITI M8

pag. 1 2 3 4 5 6 7 8 9 10 11 12 13 14 15 16 17 18 19 20 21 22 23 24 25 26 27 28 29 30 31 32 33 34 35 36 37 38 39 40 41 42 43 44 45 46 47 48 49 50 51 52 53 54 55 56 57 58 59 60 61 62 63 64 65 66 67 68 69 70 71 72 73 74 75 76 77 78 79 80 81 82 83 84 85 86 87 88 89 90 91 92 93 94 95 96 97 98 99 100

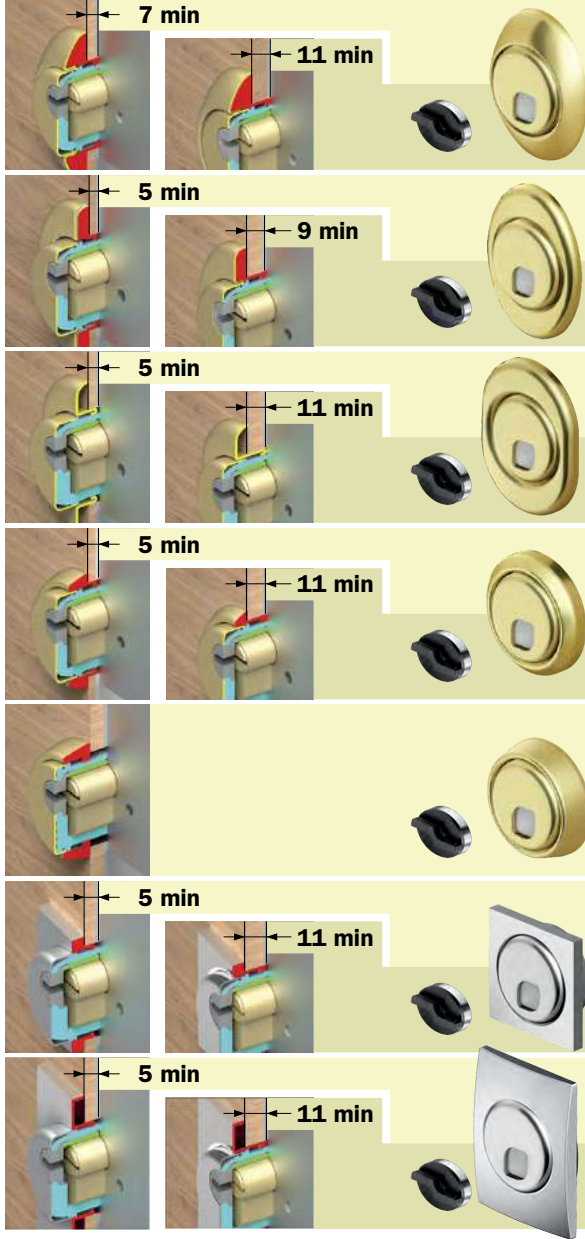
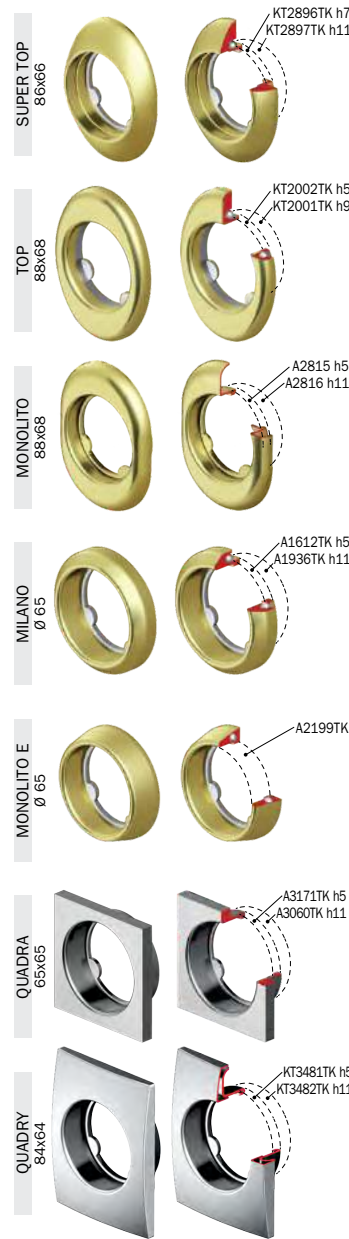
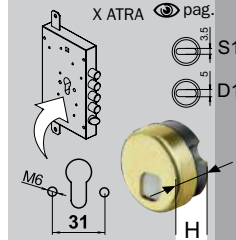
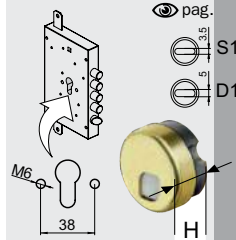
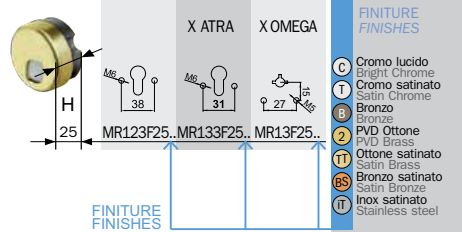

Series	Model	Height (H)	Width (S)	Depth (D)	Finish	Accessories
SUPER TOP	MRSTBF23	25	S1	D1	C, T, B, Z, TT, BS, IT	KT2896TK h7, KT2897TK h11
	MRSTAF23	25	S1	D1	C, T, B, Z, TT, BS, IT	KT2896TK h7, KT2897TK h11
TOP	MRTBF23	25	S1	D1	C, T, B, Z, TT, BS, IT	KT2002TK h5, KT2001TK h9
	MRTAF23	25	S1	D1	C, T, B, Z, TT, BS, IT	KT2002TK h5, KT2001TK h9
MONOLITO	MRM23BF	25	S1	D1	C, T, B, Z, TT, BS, IT	A2815 h5, A2816 h11
	MRM23F	25	S1	D1	C, T, B, Z, TT, BS, IT	A2815 h5, A2816 h11
MILANO	MRM23MBF	25	S1	D1	C, T, B, Z, TT, BS, IT	A1612TK h5, A1936TK h11
	MRM23MAF	25	S1	D1	C, T, B, Z, TT, BS, IT	A1612TK h5, A1936TK h11
MONOLITO E	MRME23F	25	S1	D1	C, T, B, Z, TT, BS, IT	A2199TK
	MRME23F	25	S1	D1	C, T, B, Z, TT, BS, IT	A2199TK
QUADRA	MRQAF23	25	S1	D1	C, T, B, Z, TT, BS, IT	A3171TK h5, A3060TK h11
	MRQBF23	25	S1	D1	C, T, B, Z, TT, BS, IT	A3171TK h5, A3060TK h11
QUADRY	MRWAF23	25	S1	D1	C, T, B, Z, TT, BS, IT	KT3481TK h5, KT3482TK h11
	MRWBF23	25	S1	D1	C, T, B, Z, TT, BS, IT	KT3481TK h5, KT3482TK h11



MAG ROUND

MR123

FILETTATO Ø50

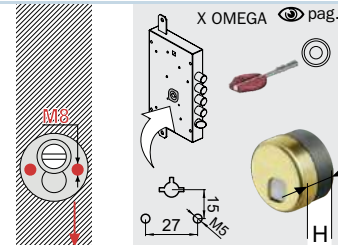
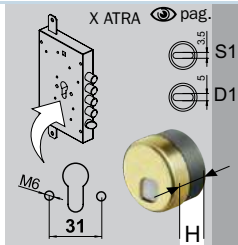
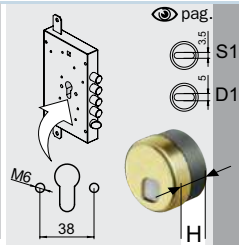
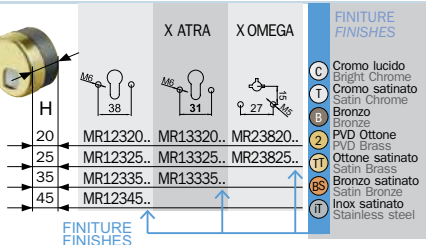

MR123 20	..	P
MR123 25	..	P
MR123 35	..	P
MR123 45	..	P
MRW123 20	..	P
MRW123 25	..	P
MRW123 35	..	P
MRW123 45	..	P
MRK123 20	..	P
MRK123 25	..	P
MRK123 35	..	P
MRK123 45	..	P

MR133 20	..	P
MR133 25	..	P
MR133 35	..	P
MRW133 20	..	P
MRW133 25	..	P
MRW133 35	..	P
MRK133 20	..	P
MRK133 25	..	P
MRK133 35	..	P

MR123 8 20..
 ESEMPIO DI CODICE PER VITI M8
 EXAMPLE OF CODE FOR FIXING M8

MR103 20	O1	P
MR103 25	O1	P
MRW103 20	O1	P
MRW103 25	O1	P
MRK103 20	O1	P
MRK103 25	O1	P

FINITURE FINISHES

- C Cromo lucido Bright Chrome
- T Cromo satinato Satin Chrome
- B Bronzo Bronze
- 2 PVD Ottonne PVD Brass
- TT Ottonne satinato Satin Brass
- BS Bronzo satinato Satin Bronze
- IT Inox satinato Stainless steel

FINITURE FINISHES

- C Cromo lucido Bright Chrome
- T Cromo satinato Satin Chrome
- B Bronzo Bronze
- 2 PVD Ottonne PVD Brass
- IT Inox satinato Stainless steel

MRZ - 23 - MAG ROUND

Ø50

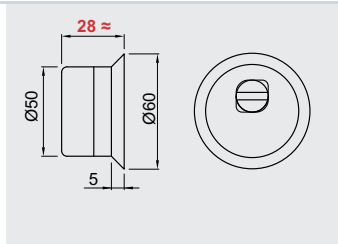
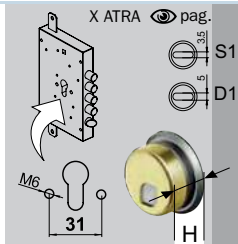
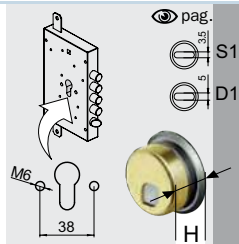
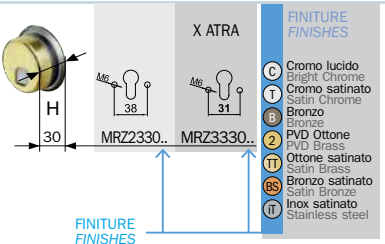

MRZ23 30	..	P
MRZW23 30	..	P
MRZK23 30	..	P

MRZ33 30	..	P
MRZW33 30	..	P
MRZK33 30	..	P

MRZ23 8 20
 ESEMPIO DI CODICE PER VITI M8
 EXAMPLE OF CODE FOR FIXING M8

MRZ23 30	O1	P
MRZW23 30	O1	P
MRZK23 30	O1	P

FINITURE FINISHES

- C Cromo lucido Bright Chrome
- T Cromo satinato Satin Chrome
- B Bronzo Bronze
- 2 PVD Ottonne PVD Brass
- TT Ottonne satinato Satin Brass
- BS Bronzo satinato Satin Bronze
- IT Inox satinato Stainless steel

FINITURE FINISHES

- C Cromo lucido Bright Chrome
- T Cromo satinato Satin Chrome
- B Bronzo Bronze
- 2 PVD Ottonne PVD Brass
- IT Inox satinato Stainless steel

FILETTATO
Ø50

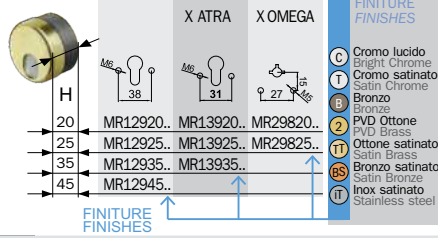

SUPER TOP
56x66

TOP
88x68

MONOLITO
88x68

MILANO
Ø 65

MONOLITO E
Ø 65

QUADRA
65x65

QUADRY
84x64

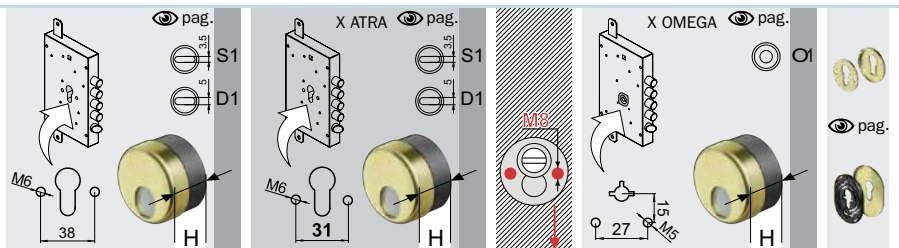
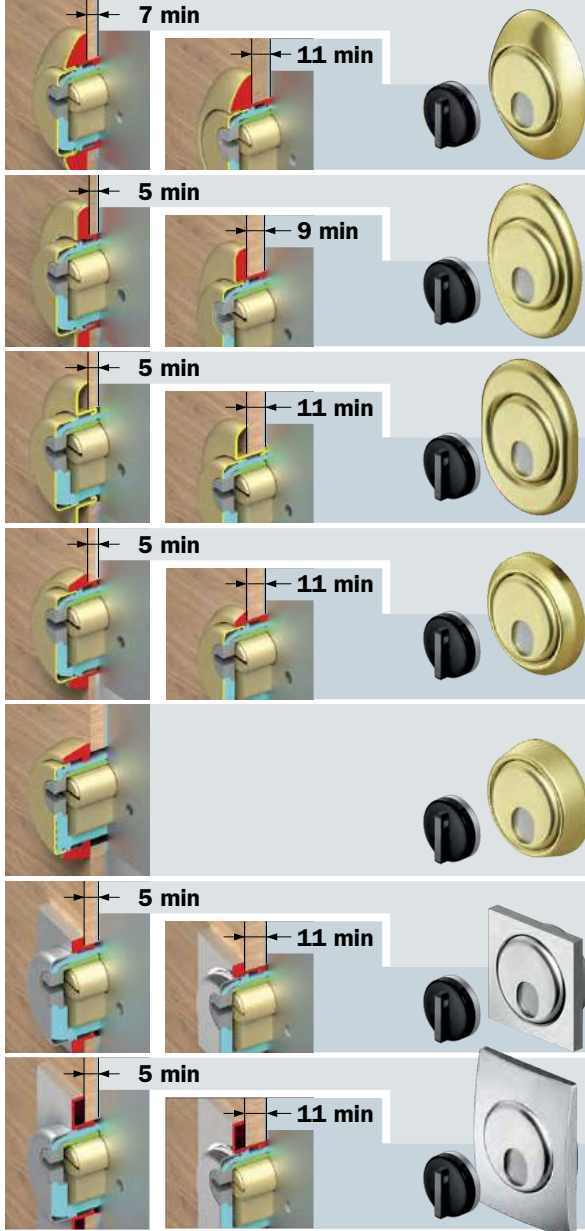

MRSTB29 20	MRSTB29 25	MRSTB29 35	MRSTB29 45	MRSTA29 20	MRSTA29 25	MRSTA29 35	MRSTA29 45	MRTB29 20	MRTB29 25	MRTB29 35	MRTB29 45	MRTA29 20	MRTA29 25	MRTA29 35	MRTA29 45	MRM29B 20	MRM29B 25	MRM29B 35	MRM29B 45	MRM29 20	MRM29 25	MRM29 35	MRM29 45	MRM29MB 20	MRM29MB 25	MRM29MB 35	MRM29MB 45	MRM29MA 20	MRM29MA 25	MRM29MA 35	MRM29MA 45	MRM29E 20	MRM29E 25	MRM29E 35	MRM29E 45	MRQA29 20	MRQA29 25	MRQA29 35	MRQA29 45	MRQB29 20	MRQB29 25	MRQB29 35	MRQB29 45	MRWA29 20	MRWA29 25	MRWA29 35	MRWA29 45	MRWB29 20	MRWB29 25	MRWB29 35	MRWB29 45
MRSTB39 20	MRSTB39 25	MRSTB39 35	MRSTB39 45	MRSTA39 20	MRSTA39 25	MRSTA39 35	MRSTA39 45	MRTB39 20	MRTB39 25	MRTB39 35	MRTB39 45	MRTA39 20	MRTA39 25	MRTA39 35	MRTA39 45	MRM39B 20	MRM39B 25	MRM39B 35	MRM39B 45	MRM39 20	MRM39 25	MRM39 35	MRM39 45	MRM39MA 20	MRM39MA 25	MRM39MA 35	MRM39MA 45	MRM39E 20	MRM39E 25	MRM39E 35	MRM39E 45	MRQA39 20	MRQA39 25	MRQA39 35	MRQA39 45	MRQB39 20	MRQB39 25	MRQB39 35	MRQB39 45	MRWA39 20	MRWA39 25	MRWA39 35	MRWA39 45	MRWB39 20	MRWB39 25	MRWB39 35	MRWB39 45				
MRSTB108 20	MRSTB108 25	MRSTB108 35	MRSTB108 45	MRSTA108 20	MRSTA108 25	MRSTA108 35	MRSTA108 45	MRTB108 20	MRTB108 25	MRTB108 35	MRTB108 45	MRTA108 20	MRTA108 25	MRTA108 35	MRTA108 45	MRM108B 20	MRM108B 25	MRM108B 35	MRM108B 45	MRM108A 20	MRM108A 25	MRM108A 35	MRM108A 45	MRM108MB 20	MRM108MB 25	MRM108MB 35	MRM108MB 45	MRM108MA 20	MRM108MA 25	MRM108MA 35	MRM108MA 45	MRM108E 20	MRM108E 25	MRM108E 35	MRM108E 45	MRQA108 20	MRQA108 25	MRQA108 35	MRQA108 45	MRQB108 20	MRQB108 25	MRQB108 35	MRQB108 45	MRWA108 20	MRWA108 25	MRWA108 35	MRWA108 45	MRWB108 20	MRWB108 25	MRWB108 35	MRWB108 45

ESEMPIO DI CODICE PER VITI M8



MR - 129 - MAG ROUND

FILETTATO

Ø50

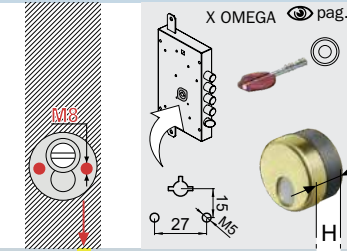
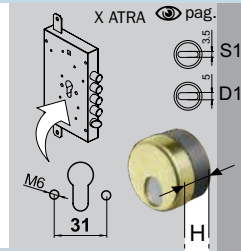
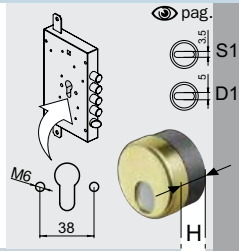
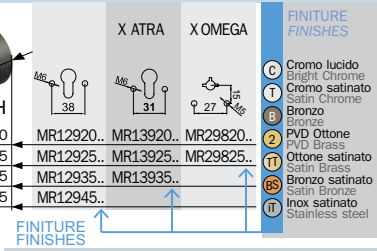

	MRW129 20 .. P
	MRW129 25 .. P
	MRW129 35 .. P
	MRW129 45 .. P
	MRK129 20 .. P
	MRK129 25 .. P
	MRK129 35 .. P
	MRK129 45 .. P

	MRW139 20 .. P
	MRW139 25 .. P
	MRW139 35 .. P
	MRK139 20 .. P
	MRK139 25 .. P
	MRK139 35 .. P

MR129 8 20..
 ESEMPIO DI CODICE PER VITI M8
 EXAMPLE OF CODE FOR FIXING M8

	MRK108 20 O1 P
	MRK108 25 O1 P

MRZ - 29 - MAG ROUND

Ø50

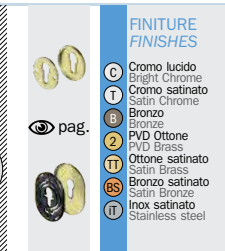
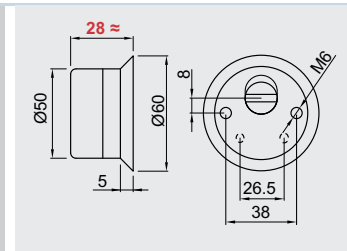
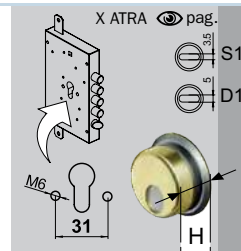
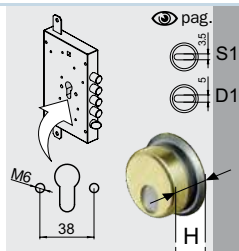
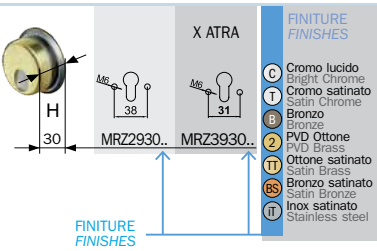

	MRW29 30 .. P
	MRW39 30 .. P
	MRZK29 30 .. P
	MRZK39 30 .. P

	MRW29 30 .. P
	MRW39 30 .. P
	MRZK29 30 .. P
	MRZK39 30 .. P

MRZ29 8 20
 ESEMPIO DI CODICE PER VITI M8
 EXAMPLE OF CODE FOR FIXING M8

	MRK29 30 O1 P
	MRK39 30 O1 P

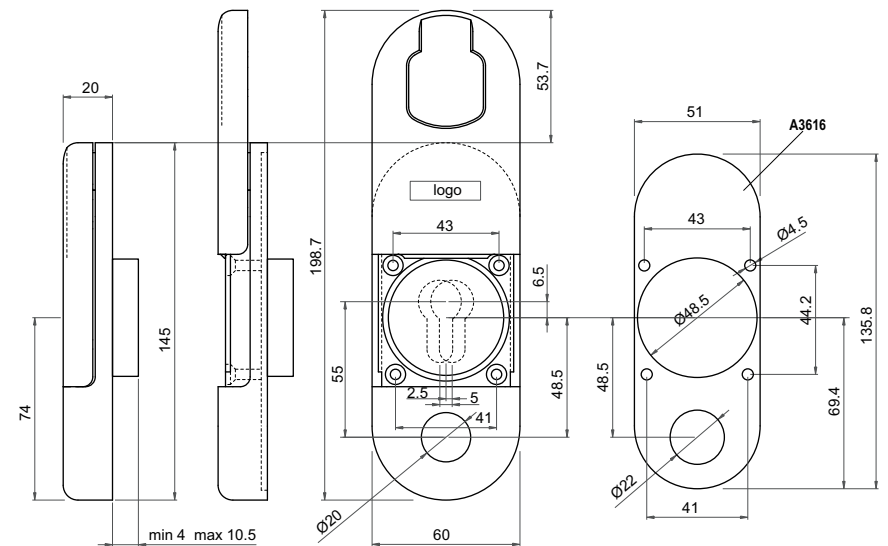
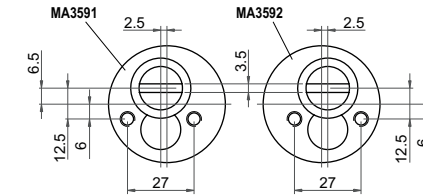
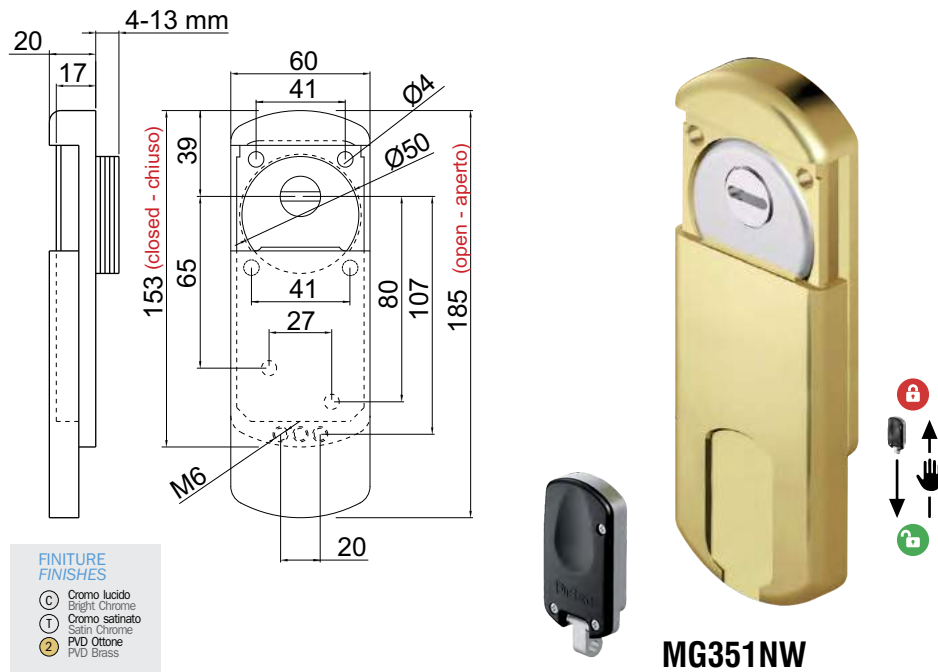
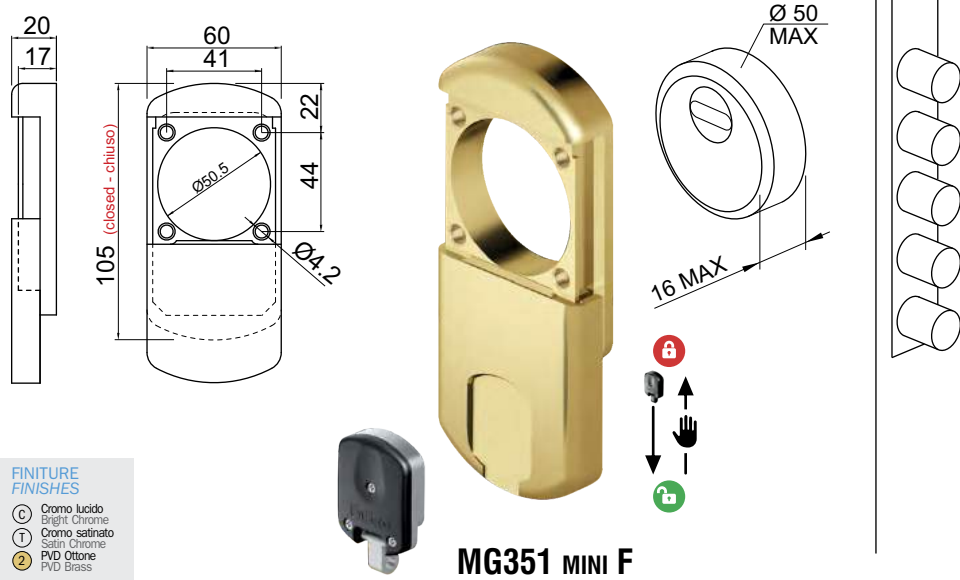

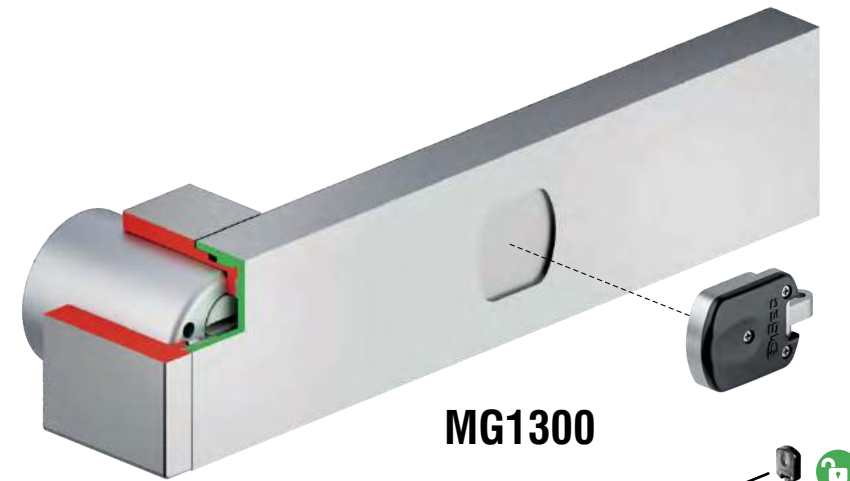
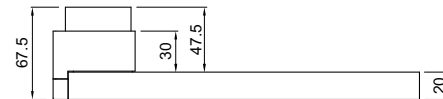
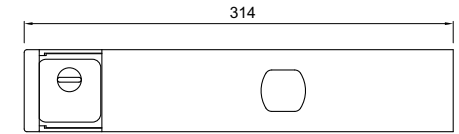
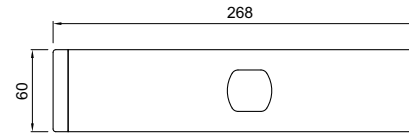

KEY BOX SERVICE KIT



KTXP70 KIT 20 pz **KM0P70**
x MG 351 NEW
x 3W



KTXP42 KIT 20 pz **KM0P42**
x MAG ROUND



KTXP40 KIT 20 pz **KM0P40**
x MAG ROUND 128



KTXP47 KIT 20 pz **KM0P47**
x MAG 4G



KM0019 KIT 20 pz **KM0006**
x 2W



KTXP55 KIT 20 pz **KM0P55**
x MG355



KM0023 KIT 20 pz **KM0027**



KTXP46 KIT 20 pz **KM0P46**
x MAG ROUND



KTXP85 KIT 20 pz **KM0P85**
x 4W



KTXP90 KIT 20 pz **KM0P90**
x 5W



KTXP3G KIT 20 pz **KM0P3G**
x 3W

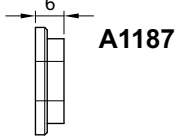
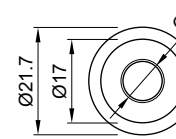
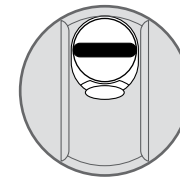
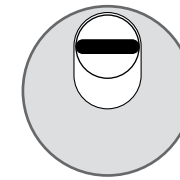
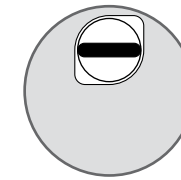
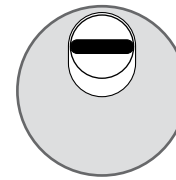

A1187

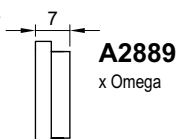
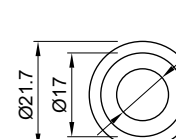

A2889
x Omega

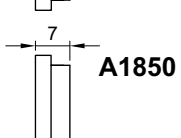
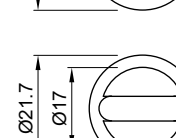

A1850

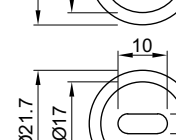

A1519
x Assa-Abloy

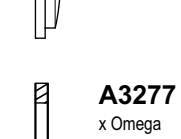
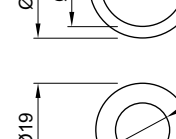

A3277
x Omega

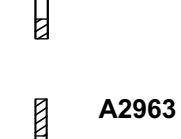
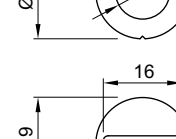

A2963

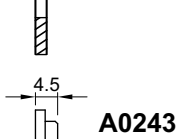
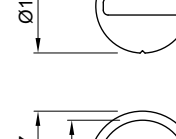

A0243

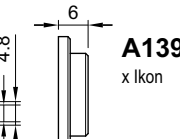
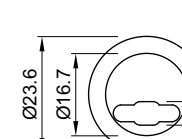

A1397
x Ikon

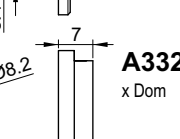
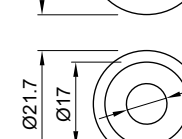

A3326
x Dom

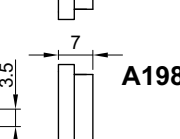
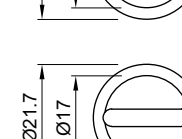

A1989

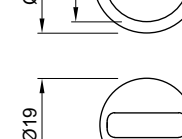

A3017

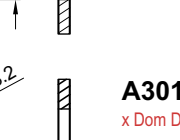
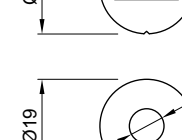

A3018
x Dom Diamant

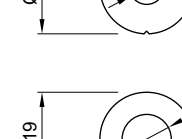

A3277
x Omega

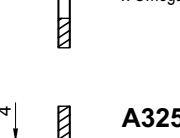
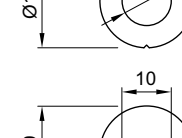

A3250
x Assa-Abloy

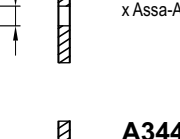
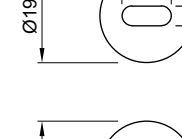

A3441
x Ikon

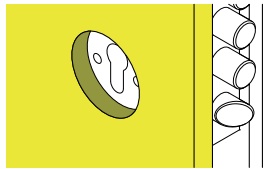
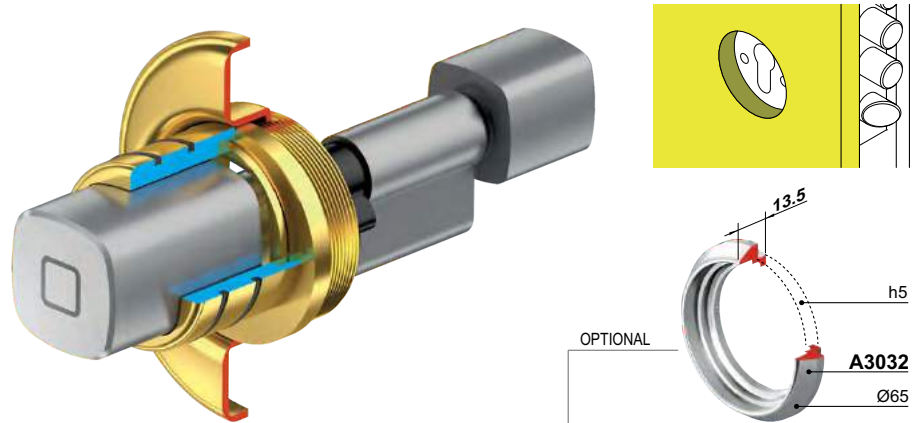

INOX



X KABA
XE510
XE511 X ATRA

OPTIONAL

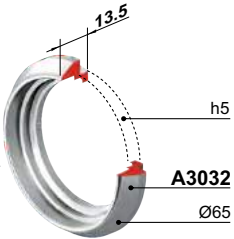

A3032
Ø65

OPTIONAL

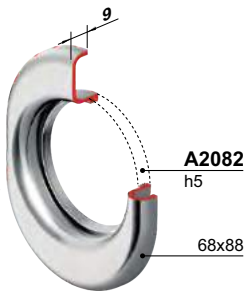

A2082
h5
68x88

OPTIONAL



KT072
68x88

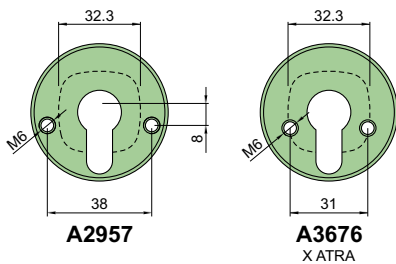
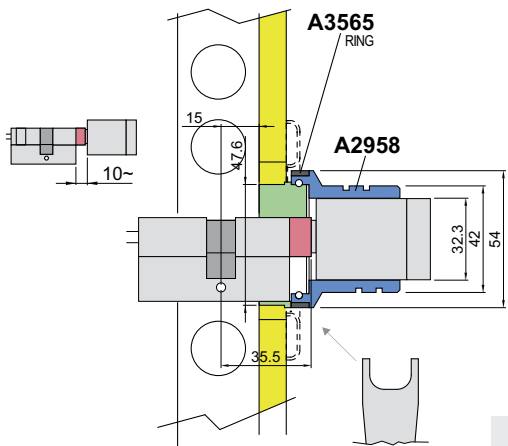

A2957
A3676
X ATRA

FINITURE / FINISHES

- ② Inox PVD gold color
- Ⓜ Inox satin



x CES
e altri

x BURG

INOX



X CES / X BURG
A2658
A3101 X ATRA

OPTIONAL

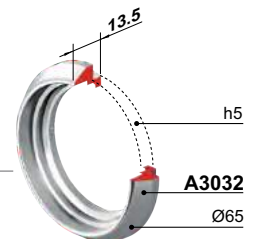

A3032
Ø65

OPTIONAL

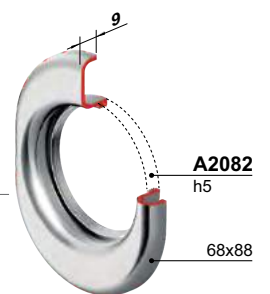

A2082
h5
68x88

OPTIONAL



KT072
68x88

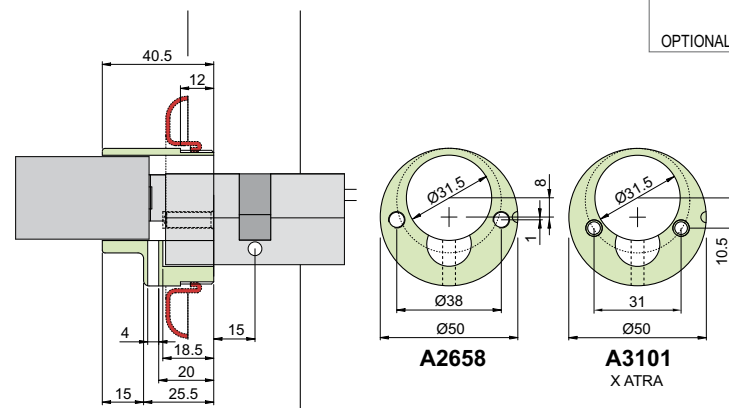

A2658

A3101
X ATRA

FINITURE / FINISHES

- ② Inox PVD gold color
- Ⓜ Inox satin

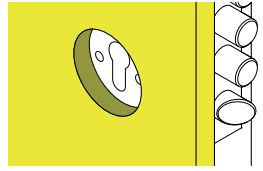
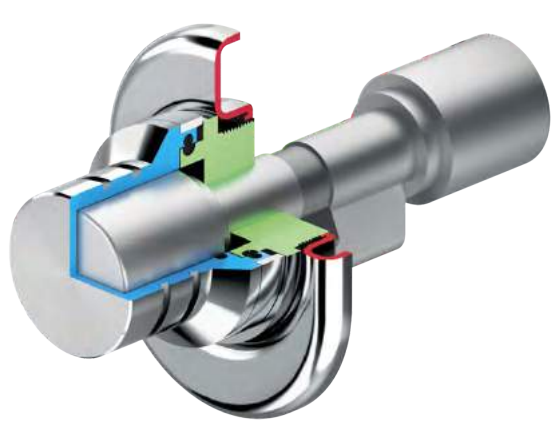

INOX

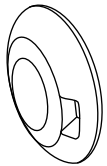

X SIMONS VOSS
XE601
XE607 X ATRA

OPTIONAL

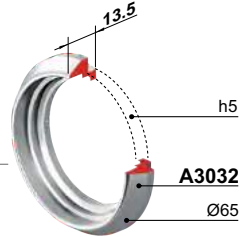

OPTIONAL

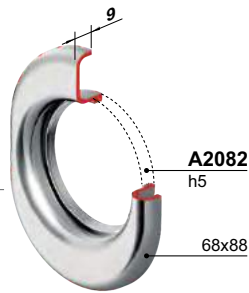

OPTIONAL

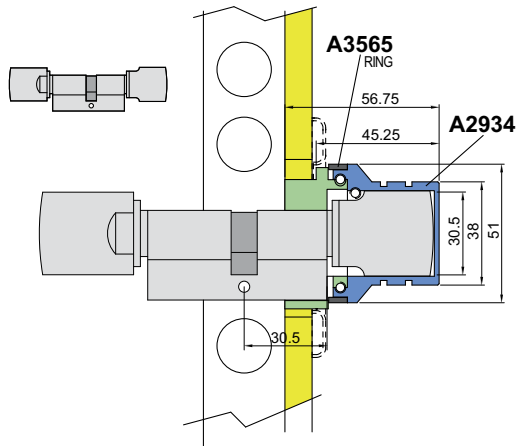

FINITURE / FINISHES

② Inox PVD gold color Ⓜ Inox satin

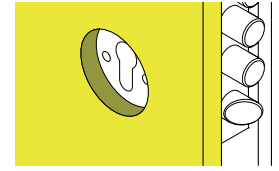
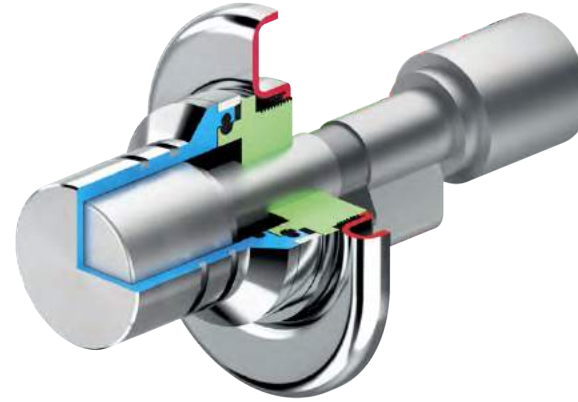

INOX



X SIMONS VOSS
XE609
XE610 X ATRA

OPTIONAL

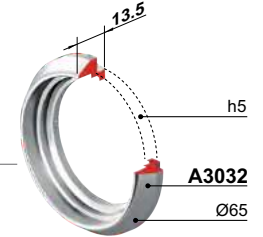

OPTIONAL

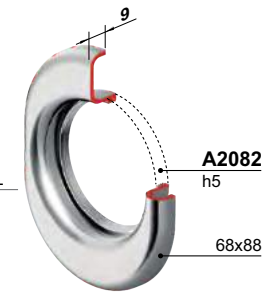

OPTIONAL

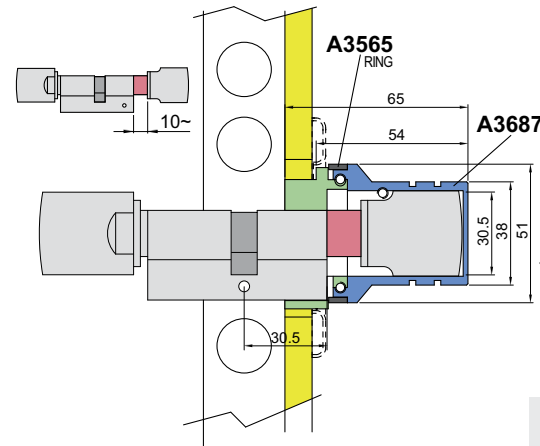

FINITURE / FINISHES

② Inox PVD gold color Ⓜ Inox satin

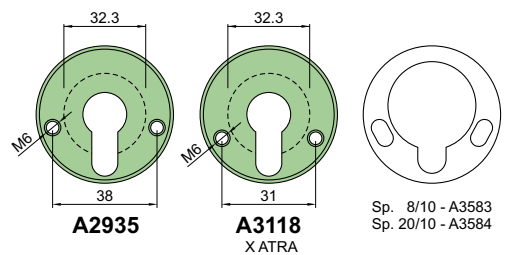
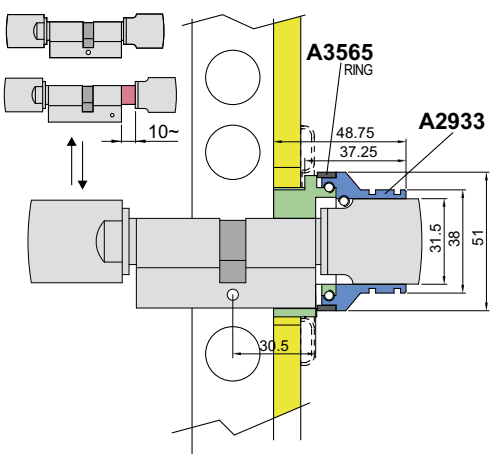
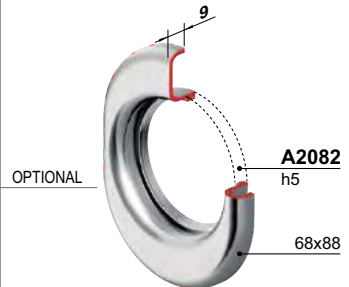
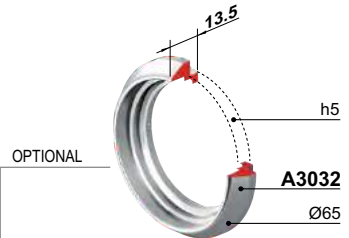
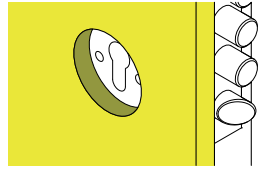
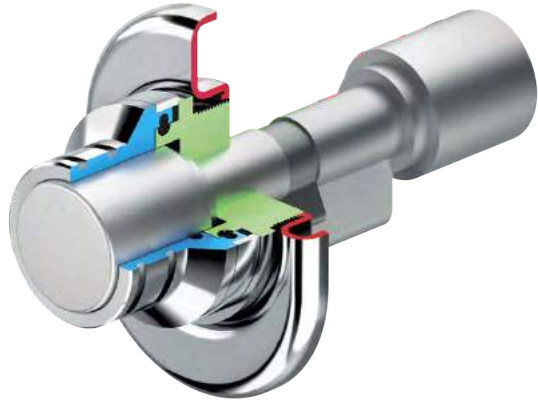

FINITURE / FINISHES
② Inox PVD gold color (IT) Inox satin

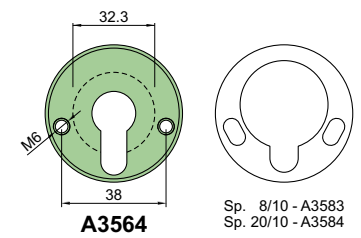
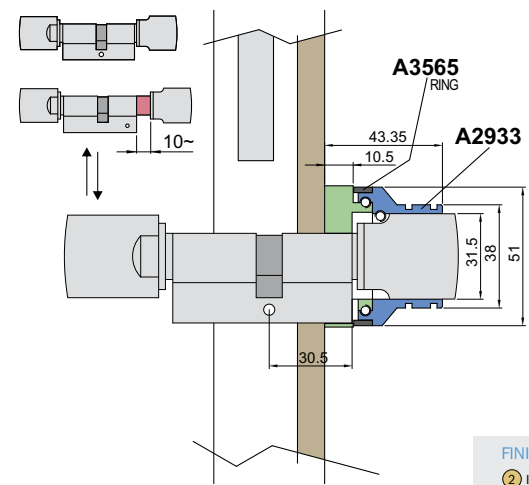
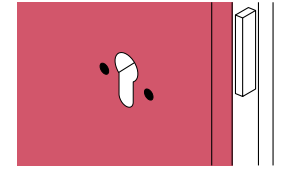
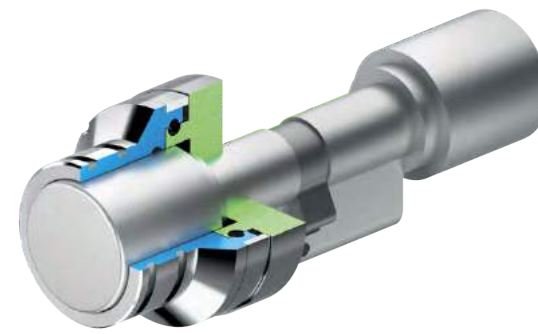

FINITURE / FINISHES
② Inox PVD gold color (IT) Inox satin

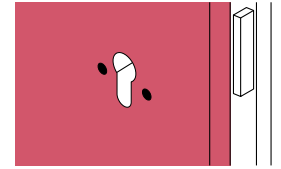
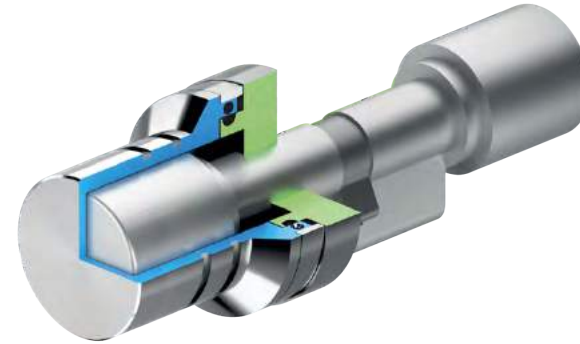
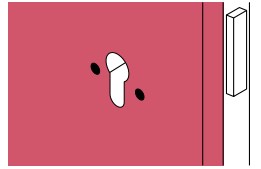
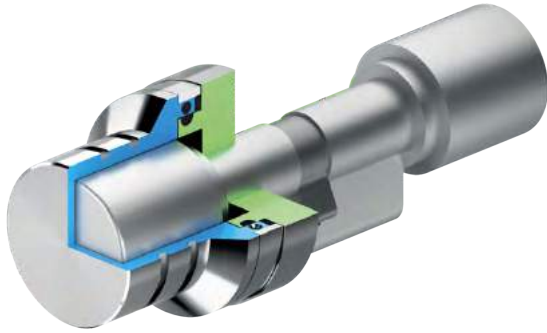

INOX

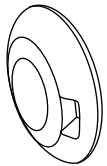

OPTIONAL



KT072
68x88

X SIMONS VOSS XE606

INOX



OPTIONAL



KT072
68x88

X SIMONS VOSS XE611

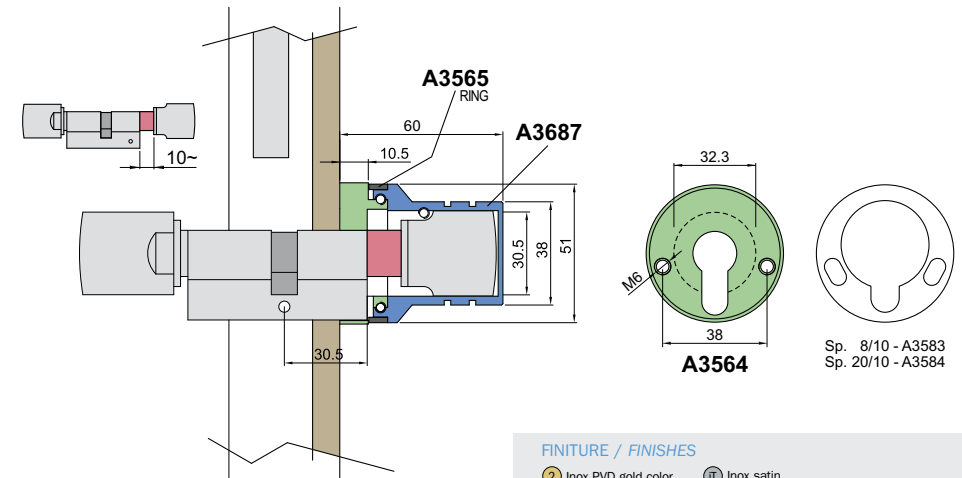
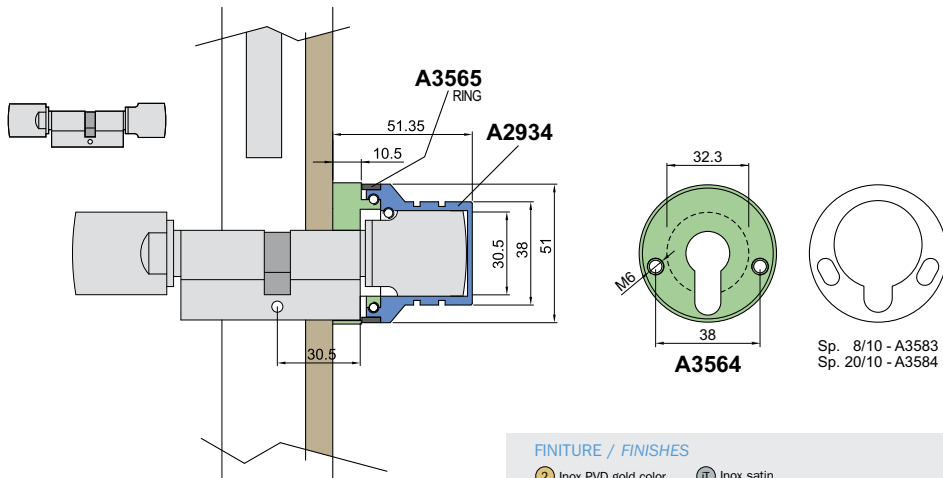

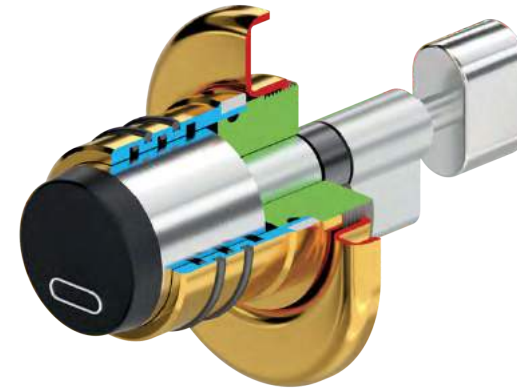
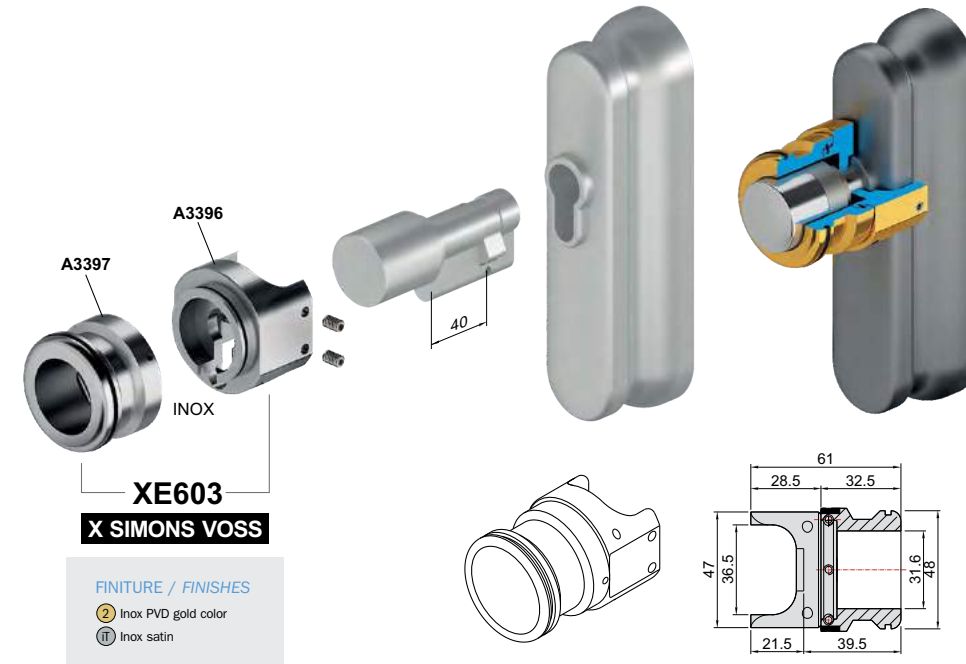
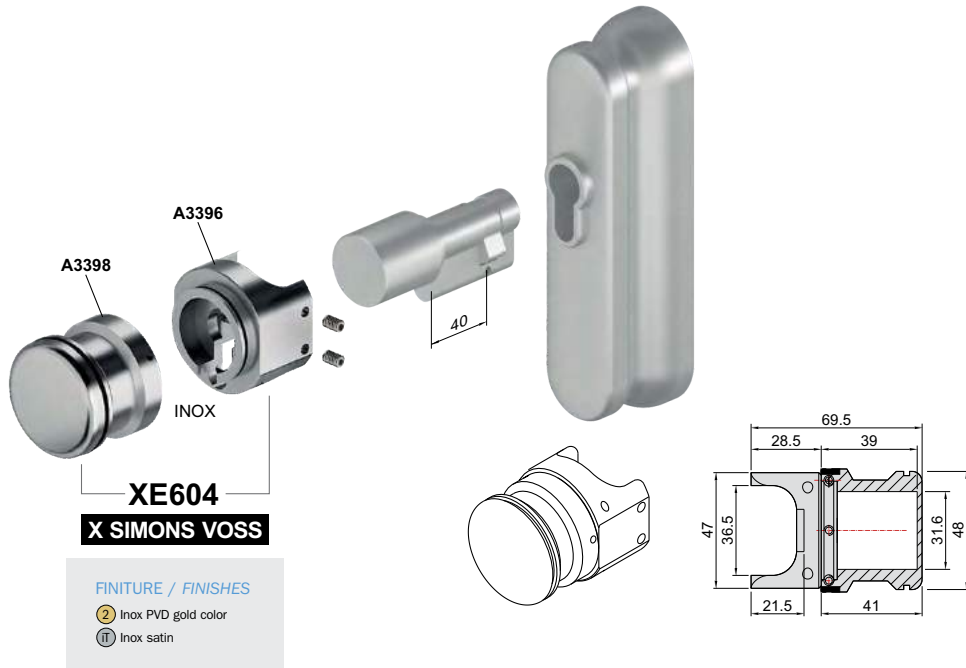

INOX



X EVVA
XE620
XE630 X ATRA

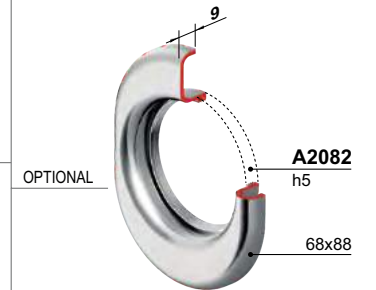
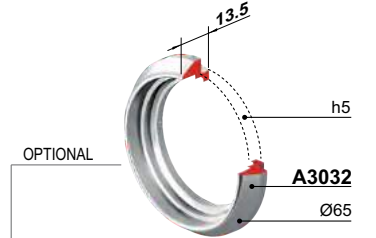
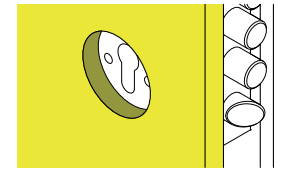
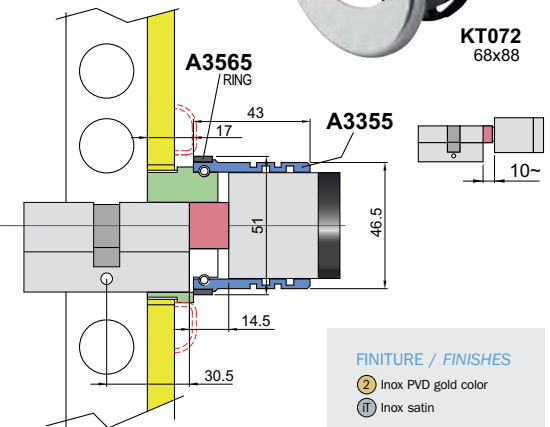
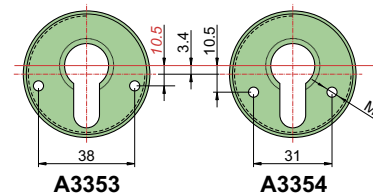
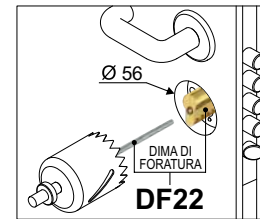

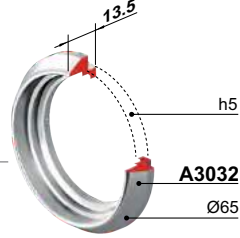
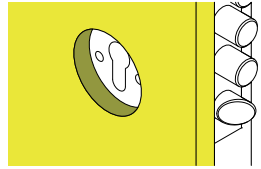
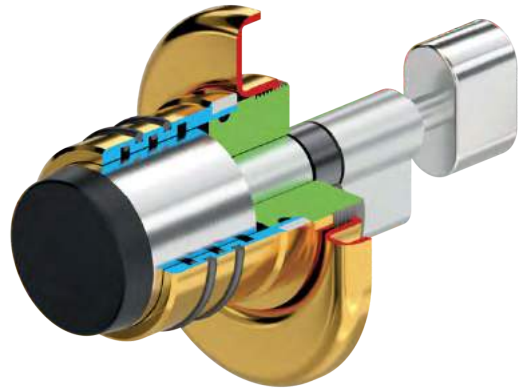

OPTIONAL

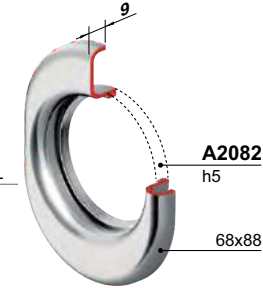

OPTIONAL



OPTIONAL

KT072
68x88

INOX



X SALTO
XE640
XE650 X ATRA

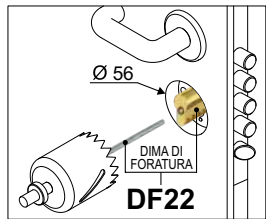

Ø 56

DIMA DI FORATURA
DF22

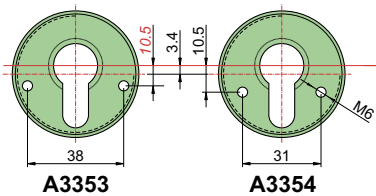

A3353

A3354
X ATRA

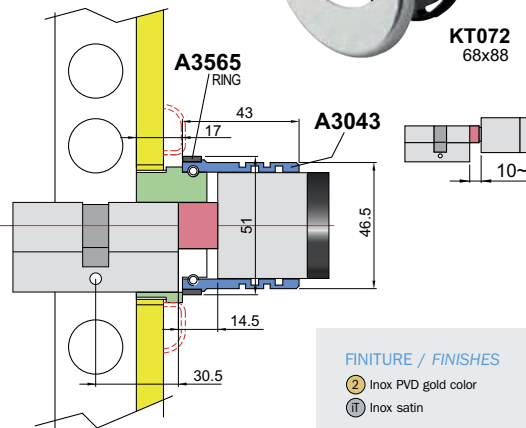

FINITURE / FINISHES

- ② Inox PVD gold color
- Ⓜ Inox satin

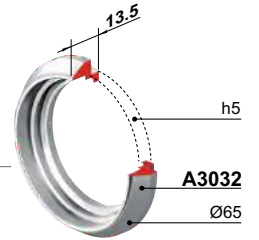
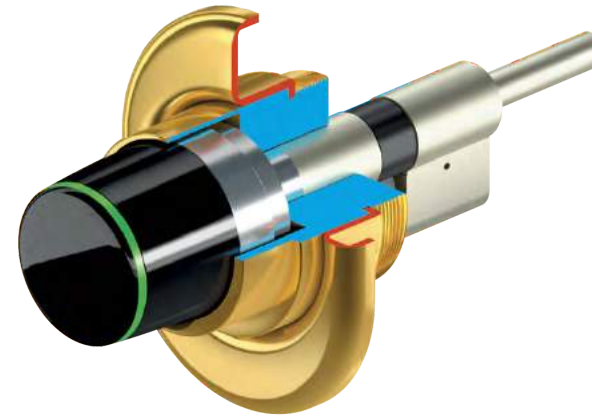

OPTIONAL

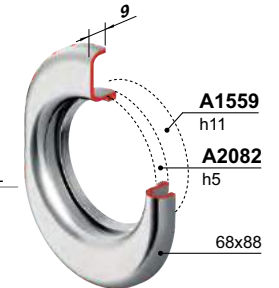

OPTIONAL



OPTIONAL

KT072
68x88

INOX



X ISEO
XE720LB
XE730LB X ATRA

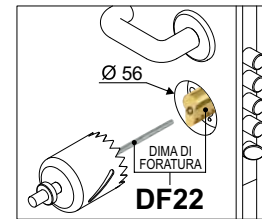

Ø 56

DIMA DI FORATURA
DF22

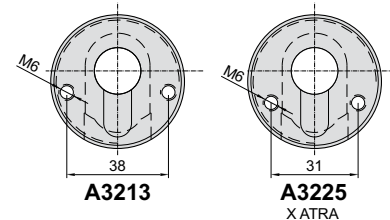

A3213

A3225
X ATRA

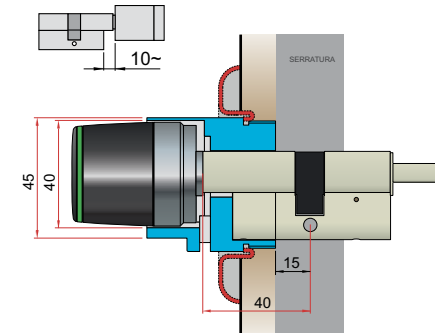
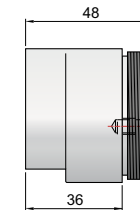

FINITURE / FINISHES

- ② Inox PVD gold color
- Ⓜ Inox satin

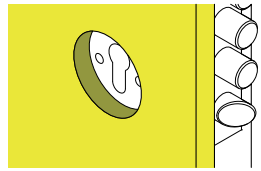
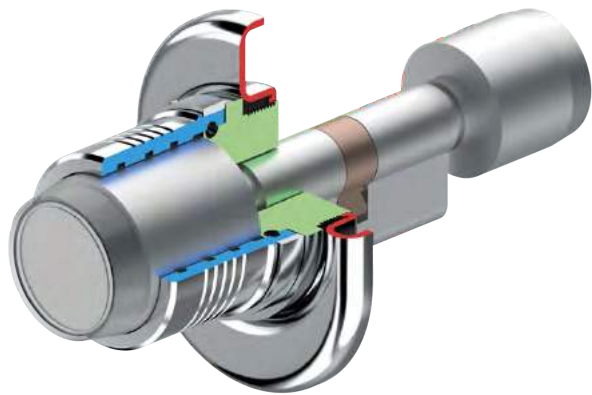

INOX



X DOM
XE660
XE670 X ATRA

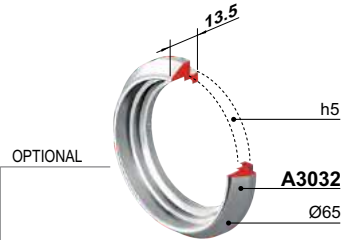

OPTIONAL

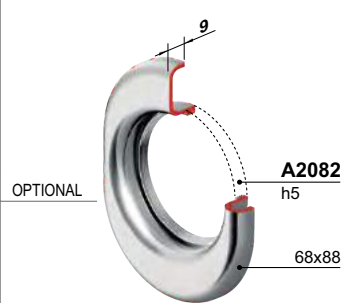

OPTIONAL



OPTIONAL

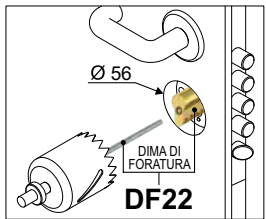

DF22

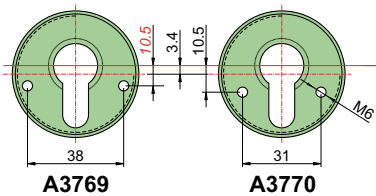

A3769

A3770
X ATRA

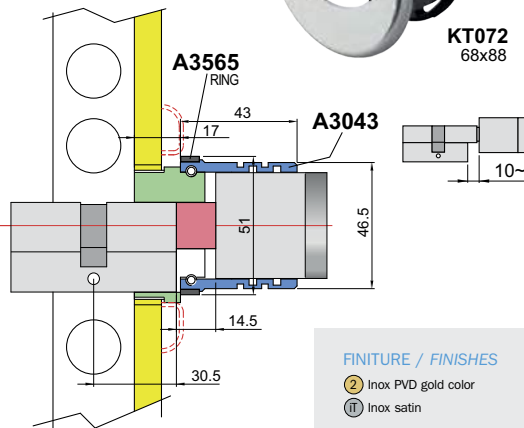

FINITURE / FINISHES

- ② Inox PVD gold color
- Ⓜ Inox satin

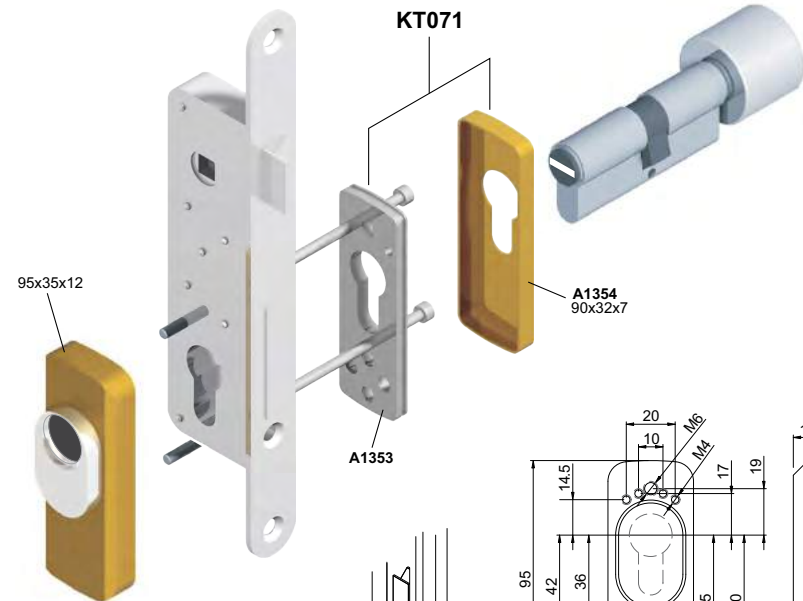

LGKBA0811
LGKBA0464

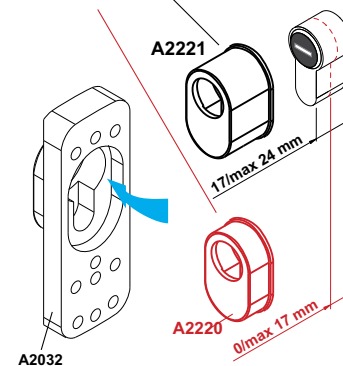

A2032

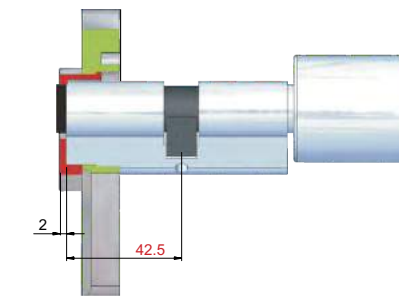

X KABA

KT071

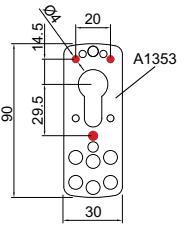
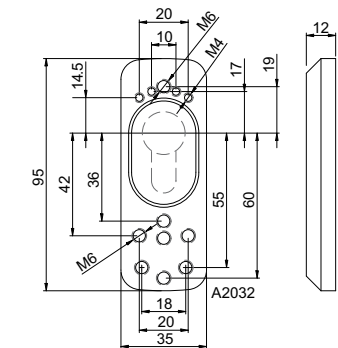

X CISA serie 16 / 46

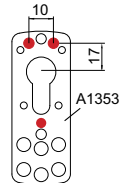

X TESA

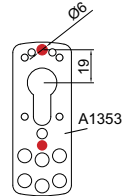

X ISEO
X MULTIBLINDO

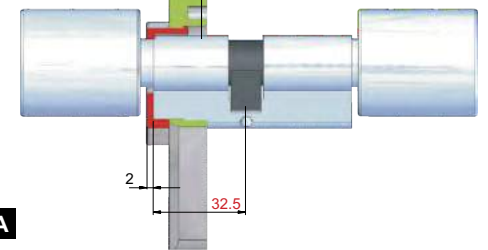
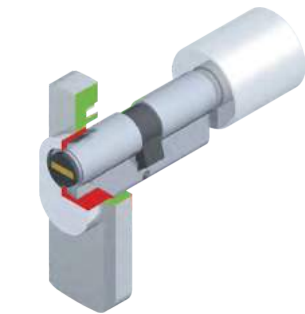

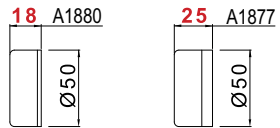
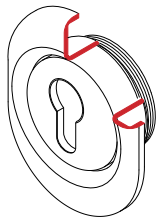
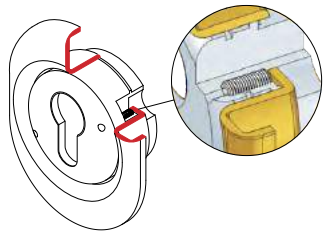
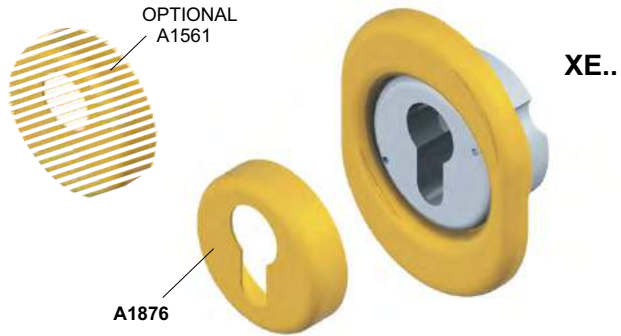

STANDARD / TESA	XE2000018	XE2000025
X ATRA	XE3000018	XE3000025

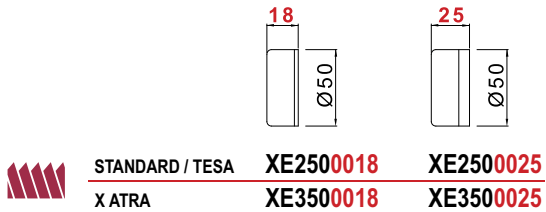

STANDARD / TESA	XE2500018	XE2500025
X ATRA	XE3500018	XE3500025

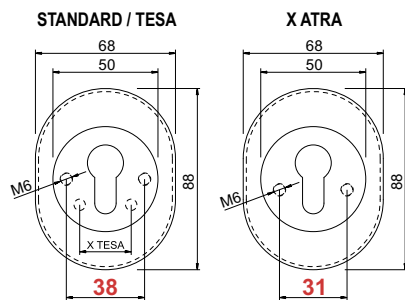
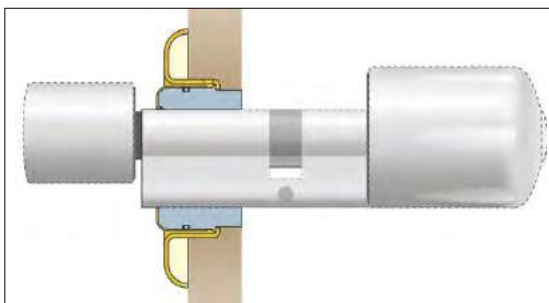

FINITURE / FINISHES

- C** Cromo lucido / Bright Chrome
- T** Cromo satinato / Satin Chrome
- B** Bronzo / Bronze
- 2** PVD Ottone / PVD Brass
- TT** Ottone satinato / Satin Brass
- 8S** Bronzo satinato / Satin Bronze
- IT** Inox satinato / Stainless steel

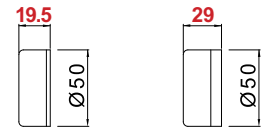
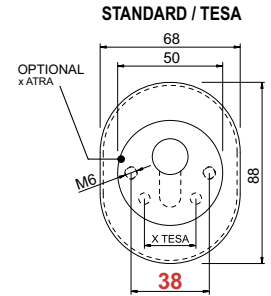
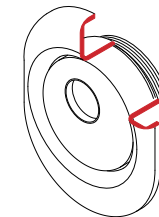
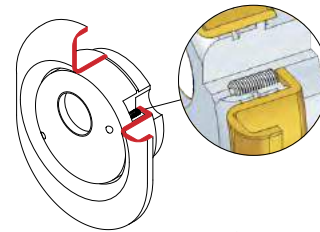
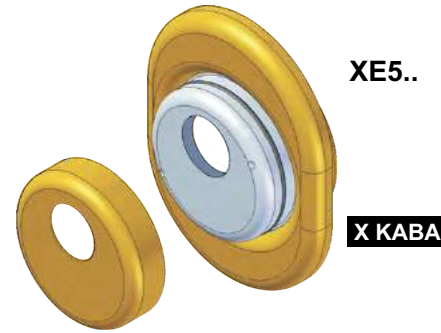

STANDARD / TESA	XE500-32	XE500-42
-----------------	-----------------	-----------------

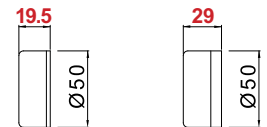

STANDARD / TESA	XE550-32	XE550-42
-----------------	-----------------	-----------------

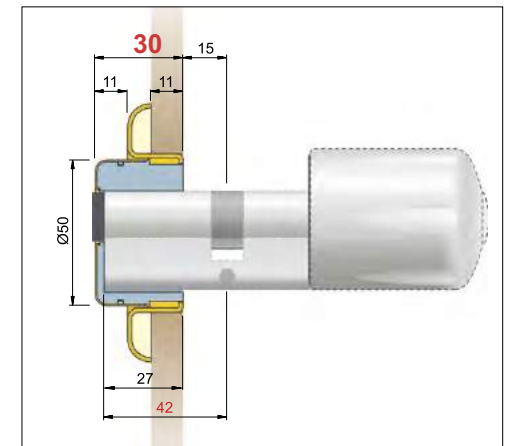
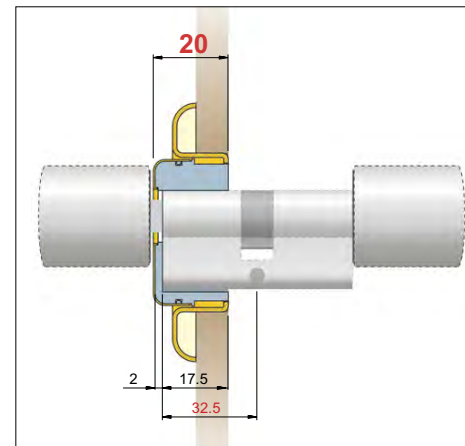

FINITURE / FINISHES

- C** Cromo lucido / Bright Chrome
- T** Cromo satinato / Satin Chrome
- B** Bronzo / Bronze
- 2** PVD Ottone / PVD Brass
- TT** Ottone satinato / Satin Brass
- 8S** Bronzo satinato / Satin Bronze
- IT** Inox satinato / Stainless steel

CONTRO DEF

CONTRO DEF



CD2000 (x viti M6)
CD2008 (x viti M8)
CD3000 x ATRA



VIDEO

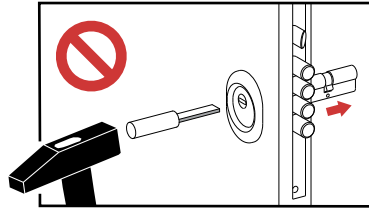
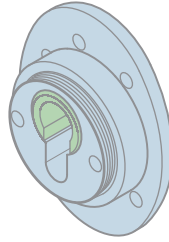

CD2100 (x viti M6)
CD2108 (x viti M8)
CD3100 x ATRA



VIDEO

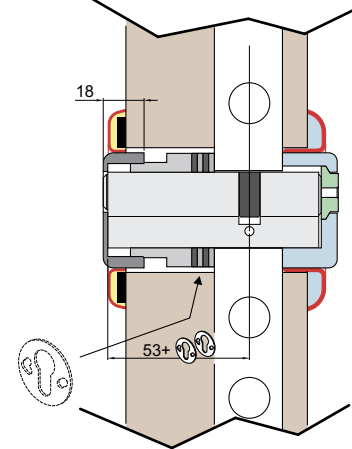
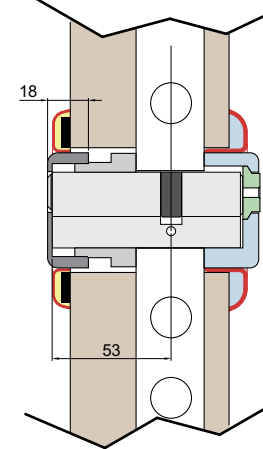
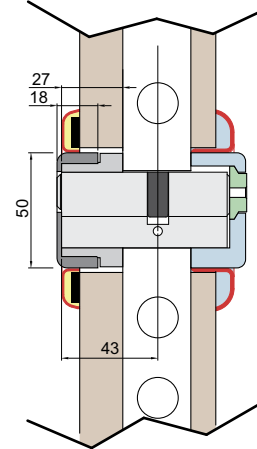
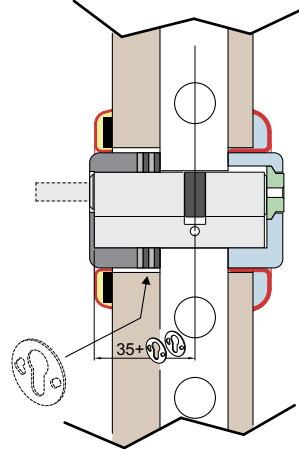
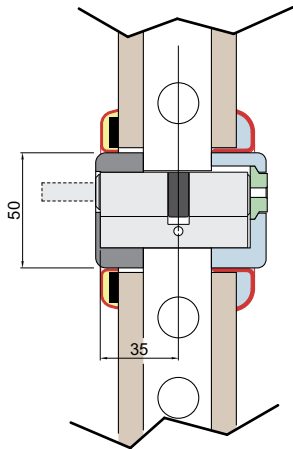
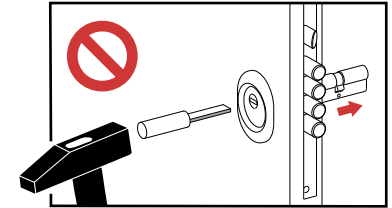
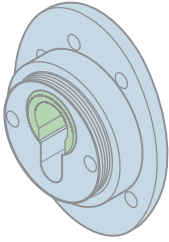

FINITURE / FINISHES

- C** Cromo lucido / Bright Chrome
- T** Cromo satinato / Satin Chrome
- OT** Ottone satinato / Satin Brass
- BS** Bronzo satinato / Satin Bronze
- B** Bronzo / Bronze
- 2** PVD Ottone / PVD Brass
- IT** Inox satinato / Satin stainless steel

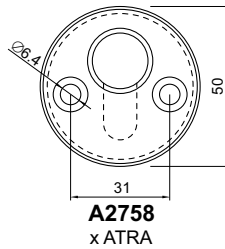
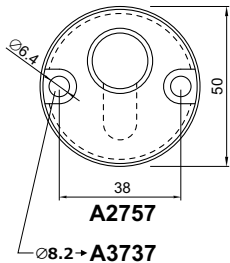
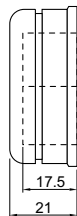

FINITURE / FINISHES

- C** Cromo lucido / Bright Chrome
- T** Cromo satinato / Satin Chrome
- OT** Ottone satinato / Satin Brass
- BS** Bronzo satinato / Satin Bronze
- B** Bronzo / Bronze
- 2** PVD Ottone / PVD Brass
- IT** Inox satinato / Satin stainless steel

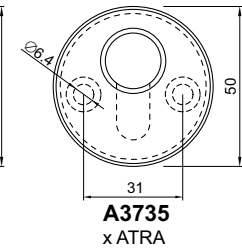
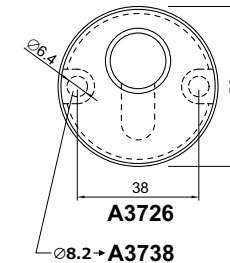
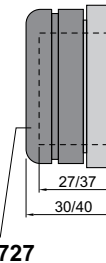

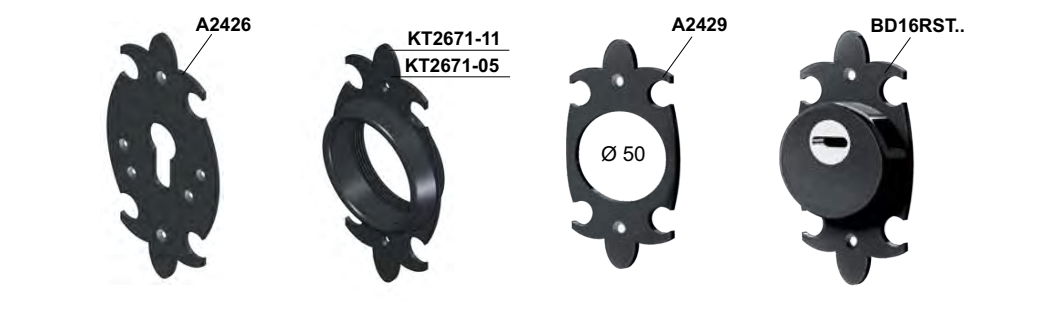
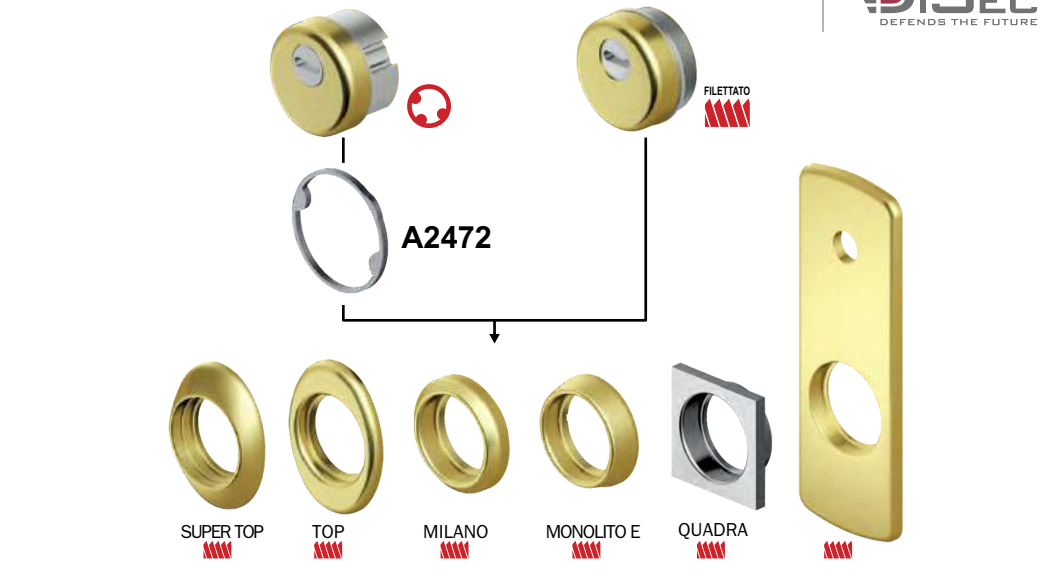

**PLACCA PER CILINDRI ELETTRONICI
ELECTRONIC CYLINDER PROTECTIONS**

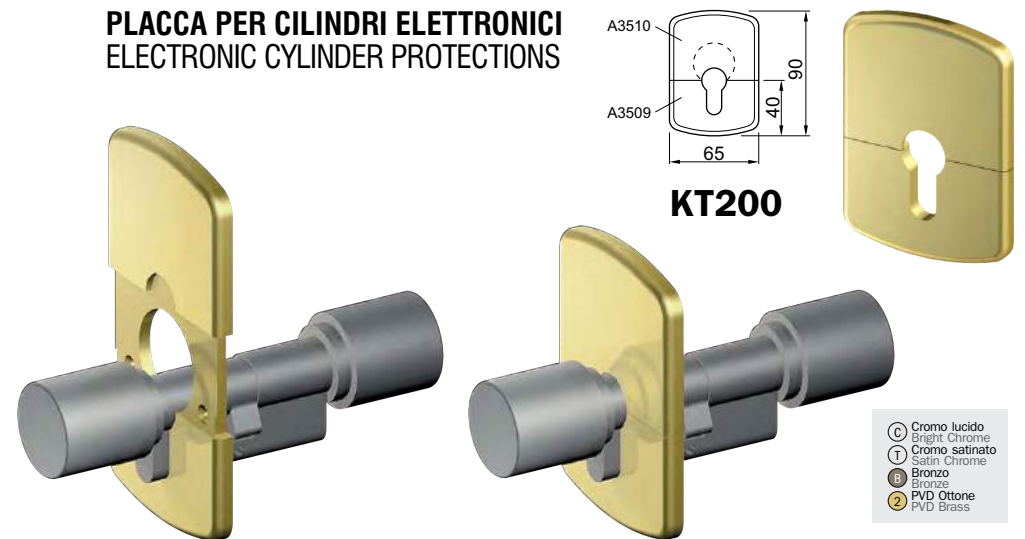

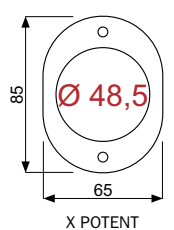
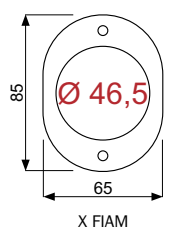
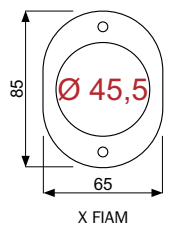
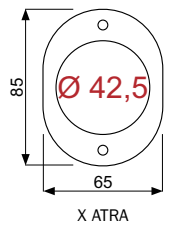
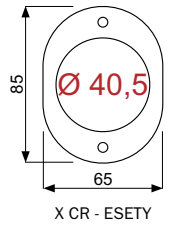
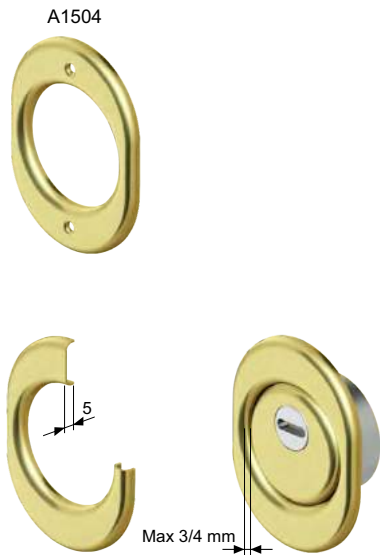
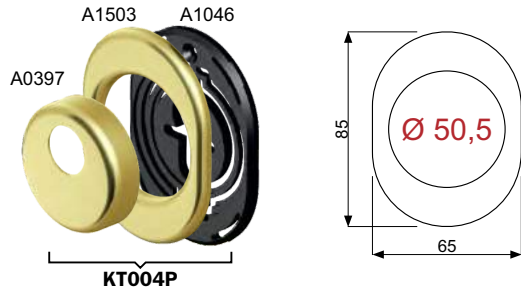

FINITURE / FINISHES

- C** Cromo lucido / Bright Chrome
- L** Ottone lucido / Bright Brass
- T** Cromo satinato / Satin Chrome
- 2** PVD Ottone / PVD Brass
- S** Cromo opaco / Mat. Chrome
- BS** Bronzo satinato / Satin Bronze
- B** Bronzo / Bronze
- N** Nero / Black

FINITURE / FINISHES

- C** Cromo lucido / Bright Chrome
- T** Cromo satinato / Satin Chrome
- S** Cromo opaco / Mat. Chrome
- B** Bronzo / Bronze
- L** Ottone lucido / Bright Brass
- 2** PVD Ottone / PVD Brass

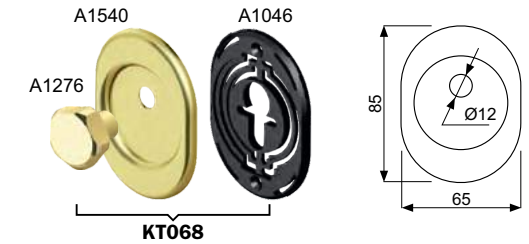
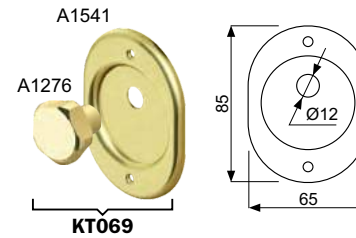
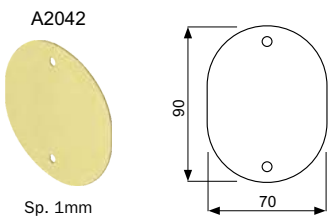
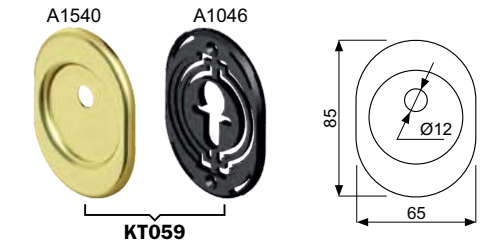
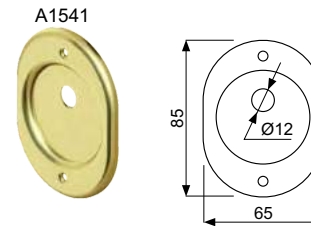
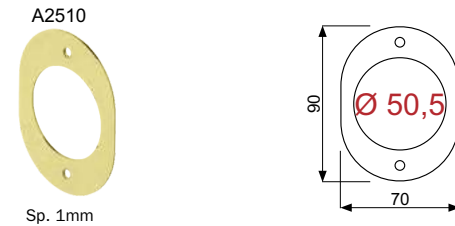
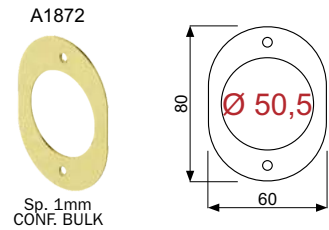
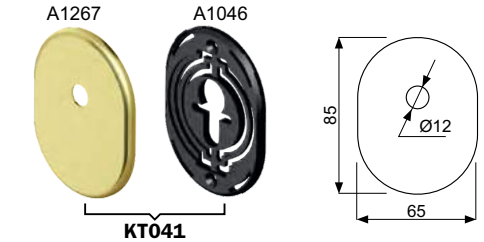
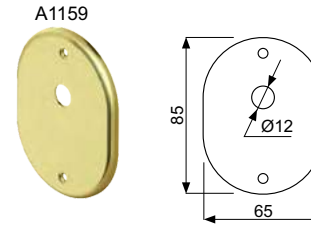
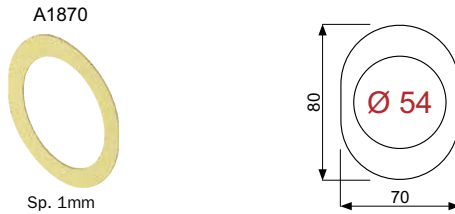
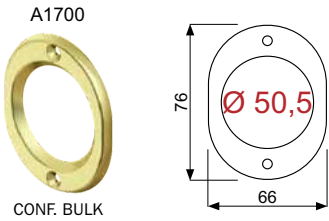
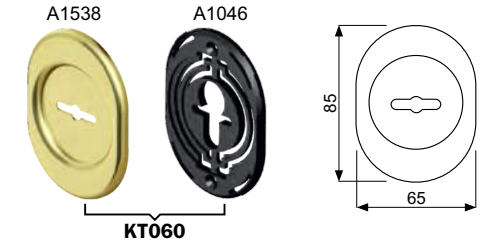
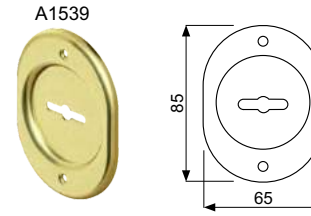
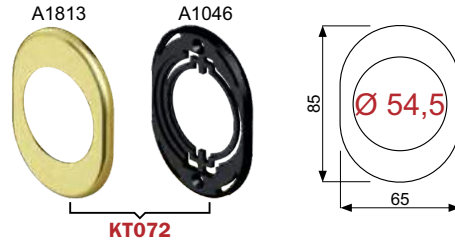
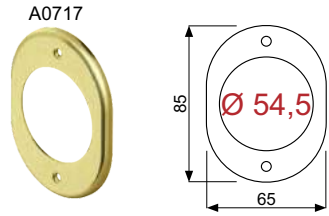
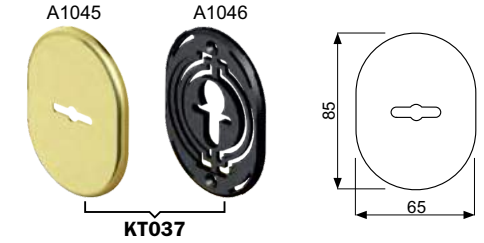
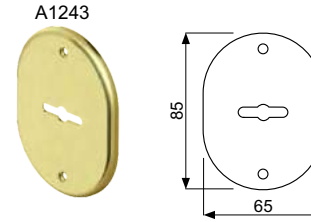
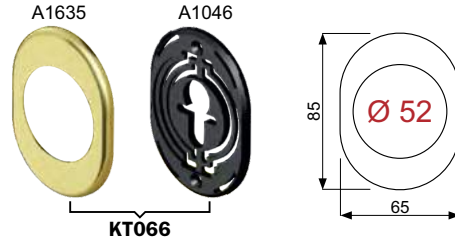
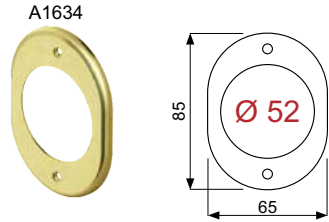

FINITURE / FINISHES

- C** Cromo lucido / Bright Chrome
- L** Ottone lucido / Bright Brass
- T** Cromo satinato / Satin Chrome
- 2** PVD Ottone / PVD Brass
- S** Cromo opaco / Mat. Chrome
- BS** Bronzo satinato / Satin Bronze
- B** Bronzo / Bronze

FINITURE / FINISHES

- C** Cromo lucido / Bright Chrome
- T** Cromo satinato / Satin Chrome
- S** Cromo opaco / Mat. Chrome
- B** Bronzo / Bronze
- L** Ottone lucido / Bright Brass
- 2** PVD Ottone / PVD Brass

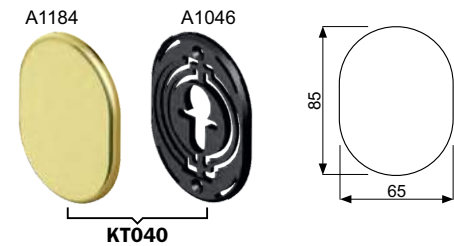
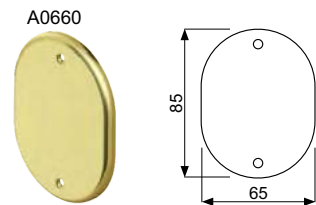
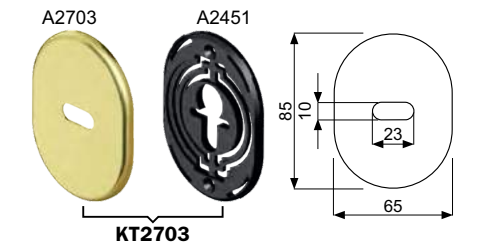
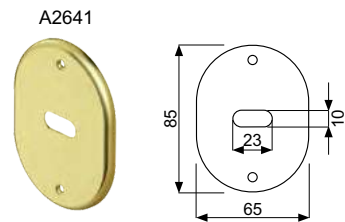
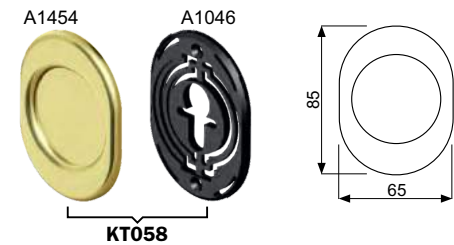
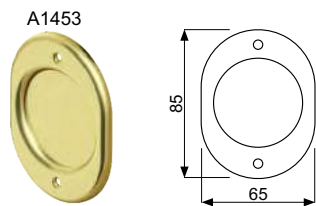
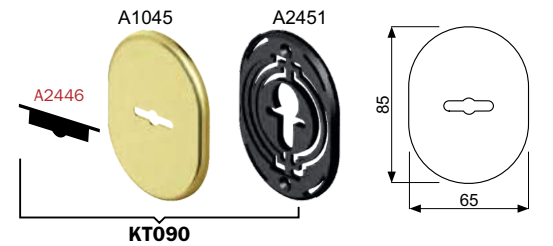
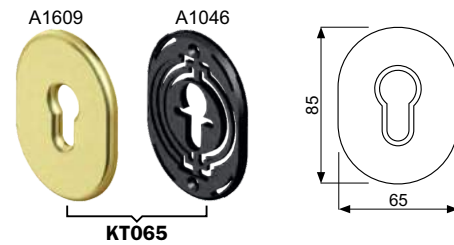
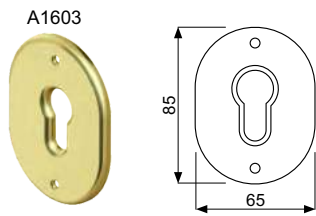
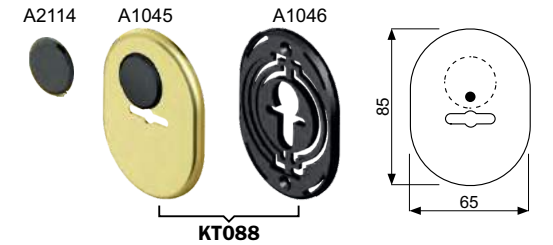
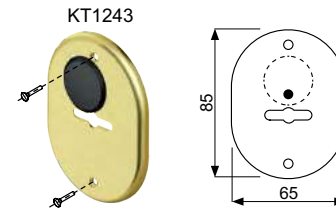
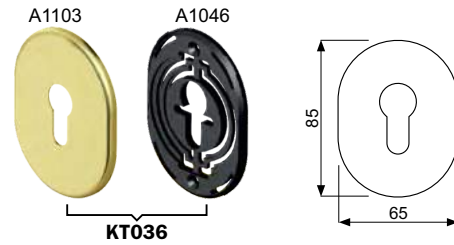
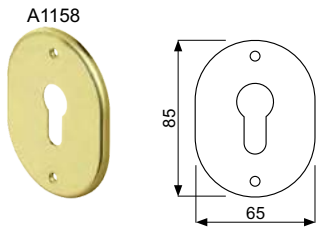
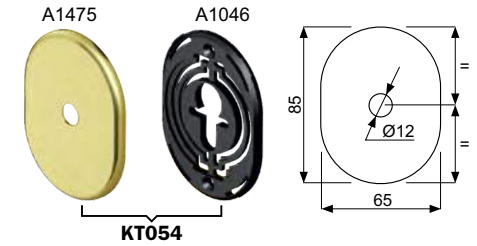
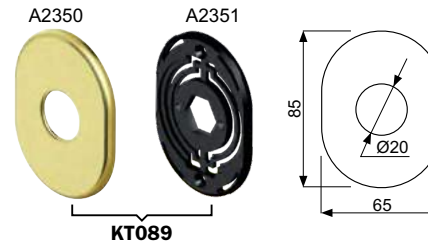
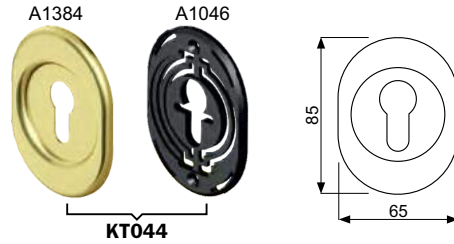
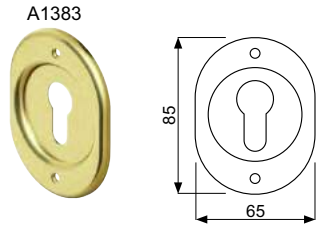

FINITURE / FINISHES

- C Cromo lucido / Bright Chrome
- T Cromo satinato / Satin Chrome
- S Cromo opaco / Mat Chrome
- B Bronzo / Bronze
- L Ottone lucido / Bright Brass
- 2 PVD Ottone / PVD Brass

FINITURE / FINISHES

- C Cromo lucido / Bright Chrome
- T Cromo satinato / Satin Chrome
- S Cromo opaco / Mat Chrome
- B Bronzo / Bronze
- L Ottone lucido / Bright Brass
- 2 PVD Ottone / PVD Brass

FINITURE / FINISHES

- C Cromo lucido Bright Chrome
- T Cromo satinato Satin Chrome
- S Inox satinato Stainless steel
- B Bronzo Bronze
- 2 PVD Ottone PVD Brass
- BS Bronzo satinato Satin Bronze

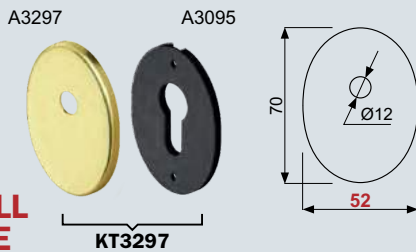
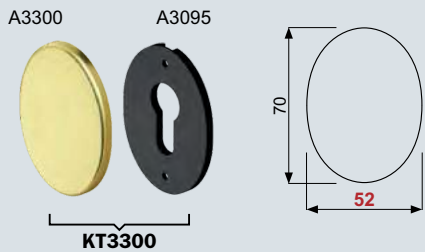
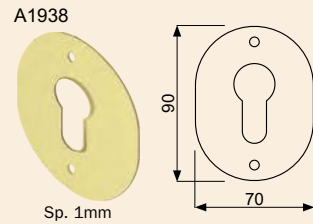
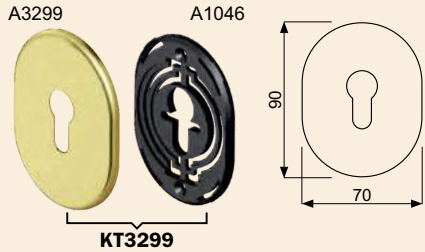
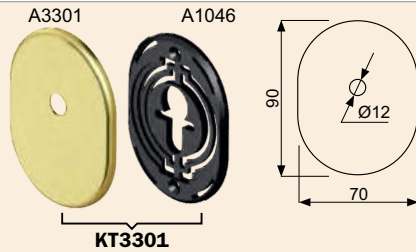
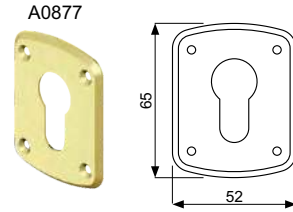
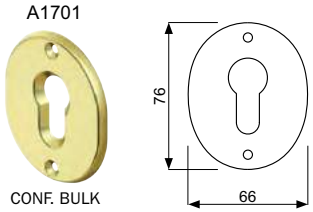

SMALL SIZE

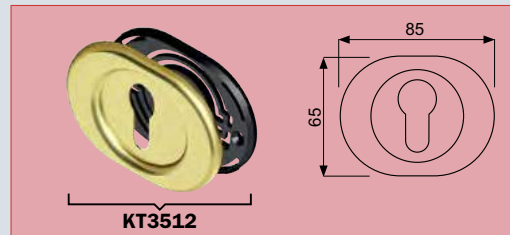
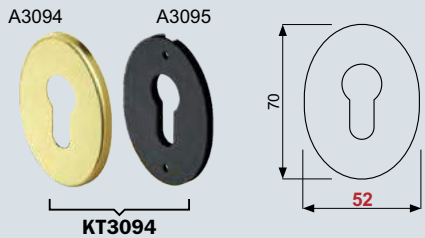

(dimensioni 60x60x6 mm)

SERIE KUBO - 65x65x6 mm

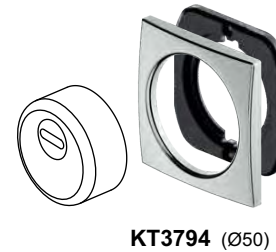

SERIE QUADRY - 64x84x6 mm



FINITURE / FINISHES

- C Cromo lucido Bright Chrome
- T Cromo satinato Satin Chrome
- S Cromo opaco Mat Chrome
- B Bronzo Bronze
- L Ottone lucido Bright Brass
- 2 PVD Ottone PVD Brass

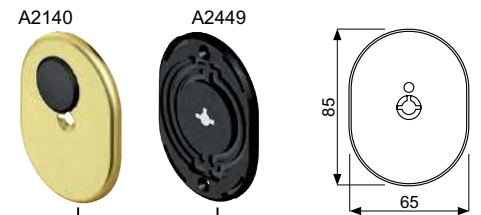
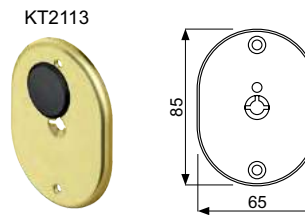
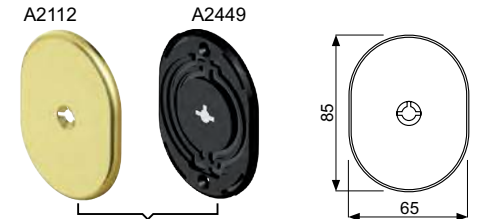
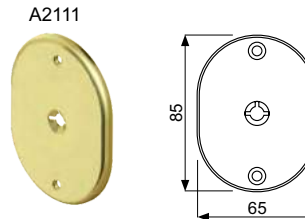
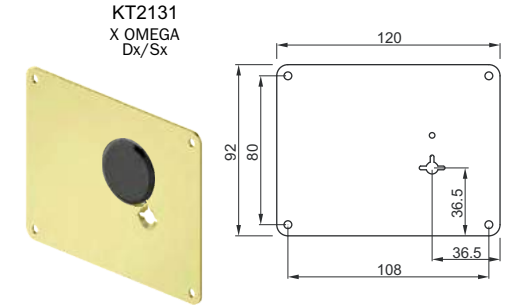
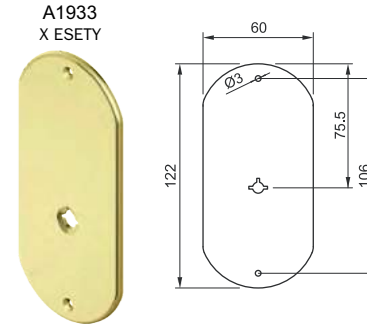
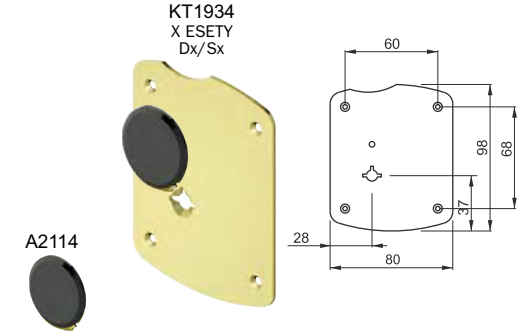
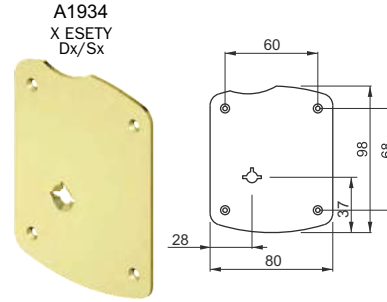
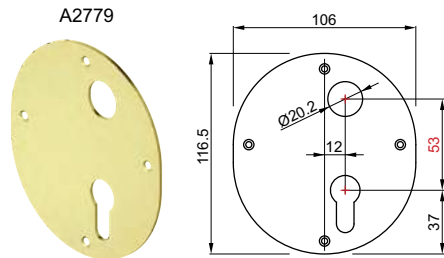
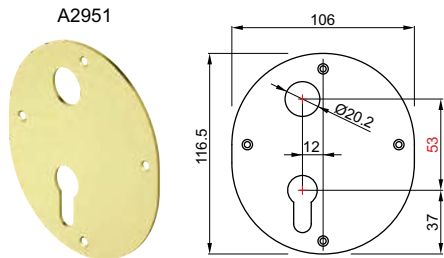
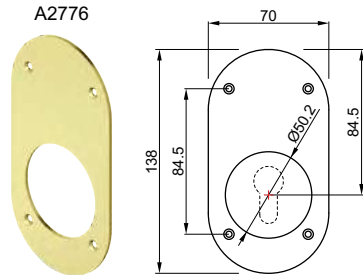
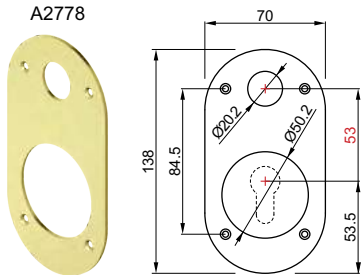
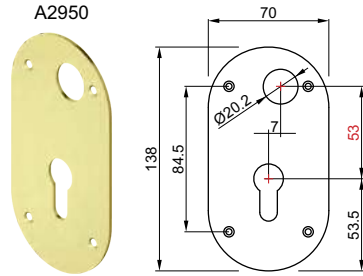
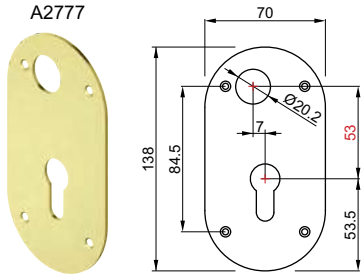

FINITURE / FINISHES

- C** Cromo lucido / Bright Chrome
- T** Cromo satinato / Satin Chrome
- B** Bronzo / Bronze
- 2** PVD Ottone / PVD Brass
- BS** Bronzo satinato / Satin Bronze

FINITURE / FINISHES

- C** Cromo lucido / Bright Chrome
- T** Cromo satinato / Satin Chrome
- IT** Inox satinato / Stainless steel
- B** Bronzo / Bronze
- L** Ottone lucido / Bright Brass
- 2** PVD Ottone / PVD Brass
- BS** Bronzo satinato / Satin Bronze

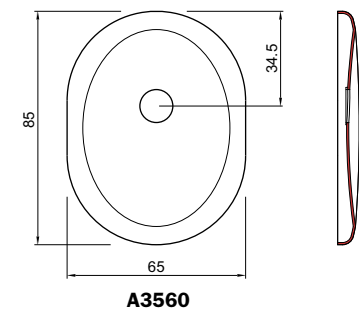
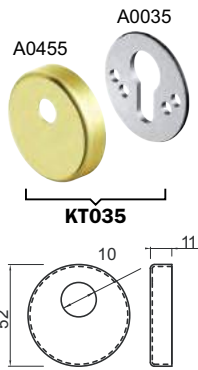
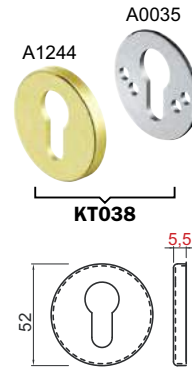
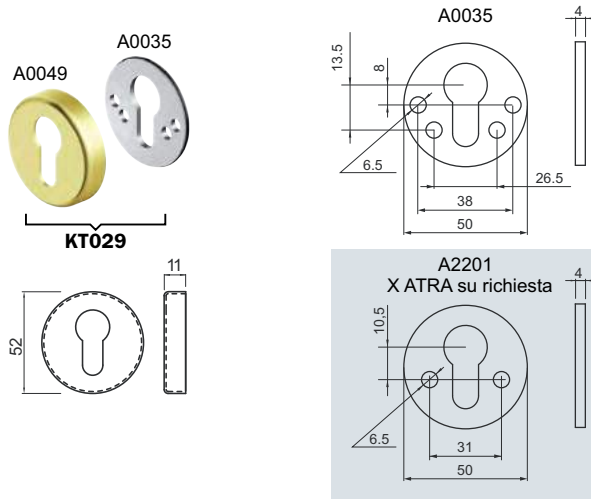

A0341
2mm

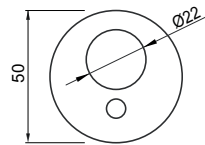

A0326
2mm

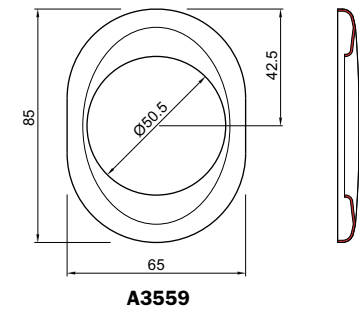
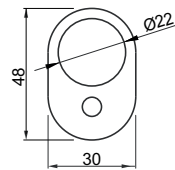

FINITURE / FINISHES

- C** Cromo lucido / Bright Chrome
- L** Ottone lucido / Bright Brass
- T** Cromo satinato / Satin Chrome
- 2** PVD Ottone / PVD Brass
- S** Cromo opaco / Mat. Chrome
- BS** Bronzo satinato / Satin Bronze
- IT** Inox satinato / Stainless steel
- N** Nero / Black
- B** Bronzo / Bronze

A2250
X ATRA
Dx/Sx



A1608
X ATRA
Dx/Sx

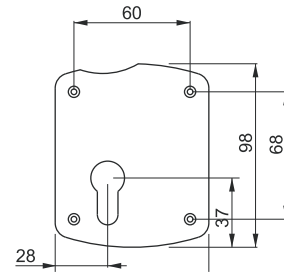

A2076



A1964
Dx/Sx

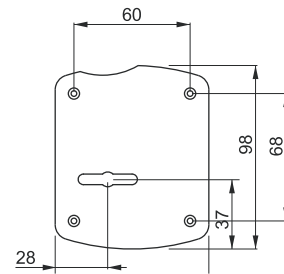

A1894
X MOTTURA

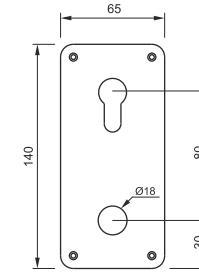

A2493
X Rif.01

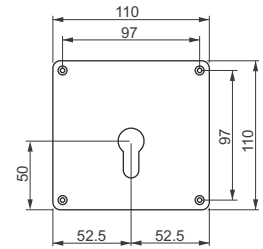

A1911
X Jewel

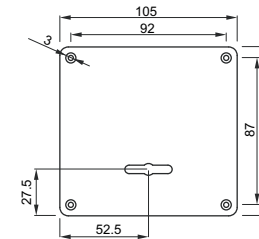

A1893
Dx/Sx
X MOTTURA
95066

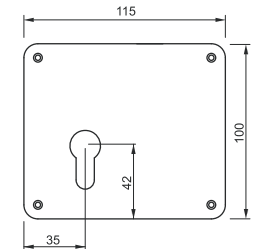

X Jewel art. 1301 1303 (X Asiaghi)

A2499

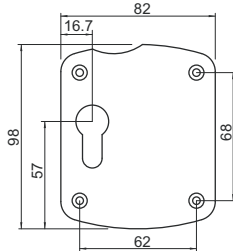

A2500

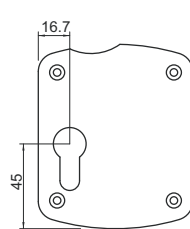

A2501

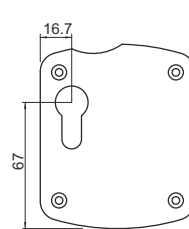

A2502

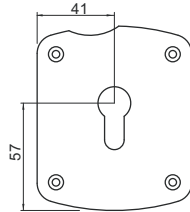

A2503

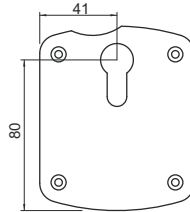

A2504

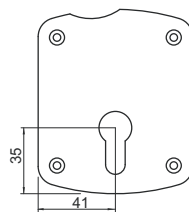

A2016
X MOTTURA
95066



A2235
Dx/Sx
X MOTTURA
95066

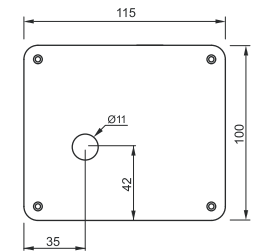

FINITURE / FINISHES

- C Cromo lucido
Bright Chrome
- T Cromo satinato
Satin Chrome
- S Cromo opaco
Mat Chrome
- B Bronzo
Bronze
- L Ottone lucido
Bright Brass
- 2 PVD Ottone
PVD Brass

FINITURE / FINISHES

- C Cromo lucido
Bright Chrome
- T Inox satinato
Stainless steel
- B Bronzo
Bronze
- L Ottone lucido
Bright Brass
- 2 PVD Ottone
PVD Brass
- BS Bronzo satinato
Satin Bronze

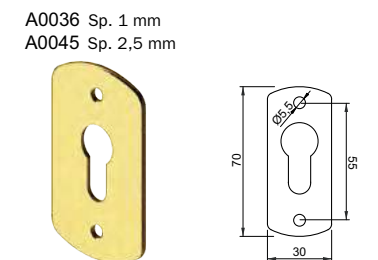
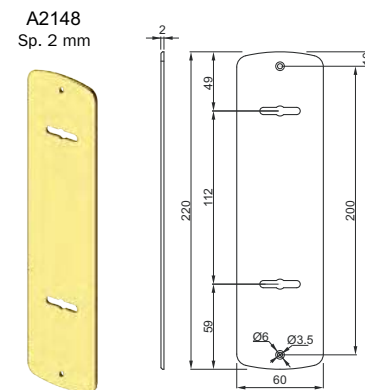
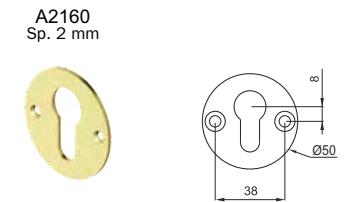
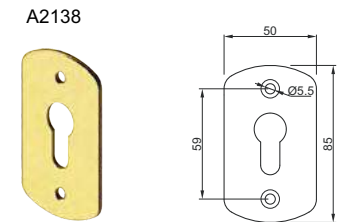
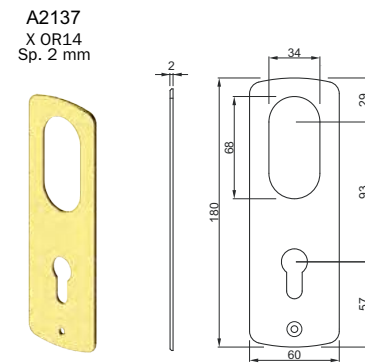
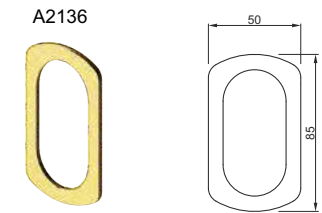
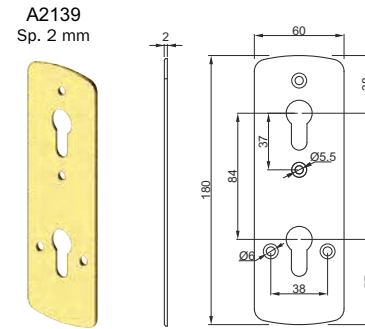
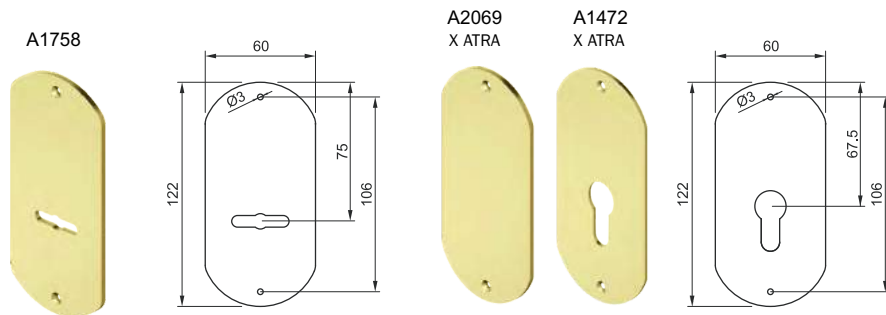
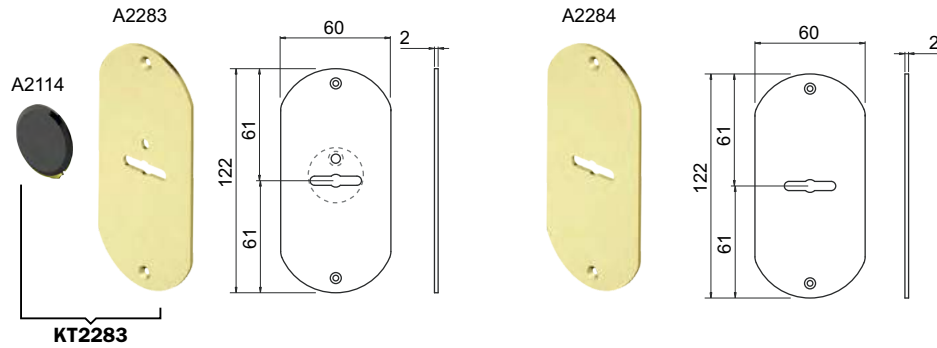

FINITURE / FINISHES

- C Cromo lucido
Bright Chrome
- T Inox satinato
Stainless steel
- B Bronzo
Bronze
- 2 PVD Ottone
PVD Brass
- S Bronzo satinato
Satin Bronze

FINITURE / FINISHES

- C Cromo lucido
Bright Chrome
- T Inox satinato
Stainless steel
- B Bronzo
Bronze
- L Ottone lucido
Bright Brass
- 2 PVD Ottone
PVD Brass

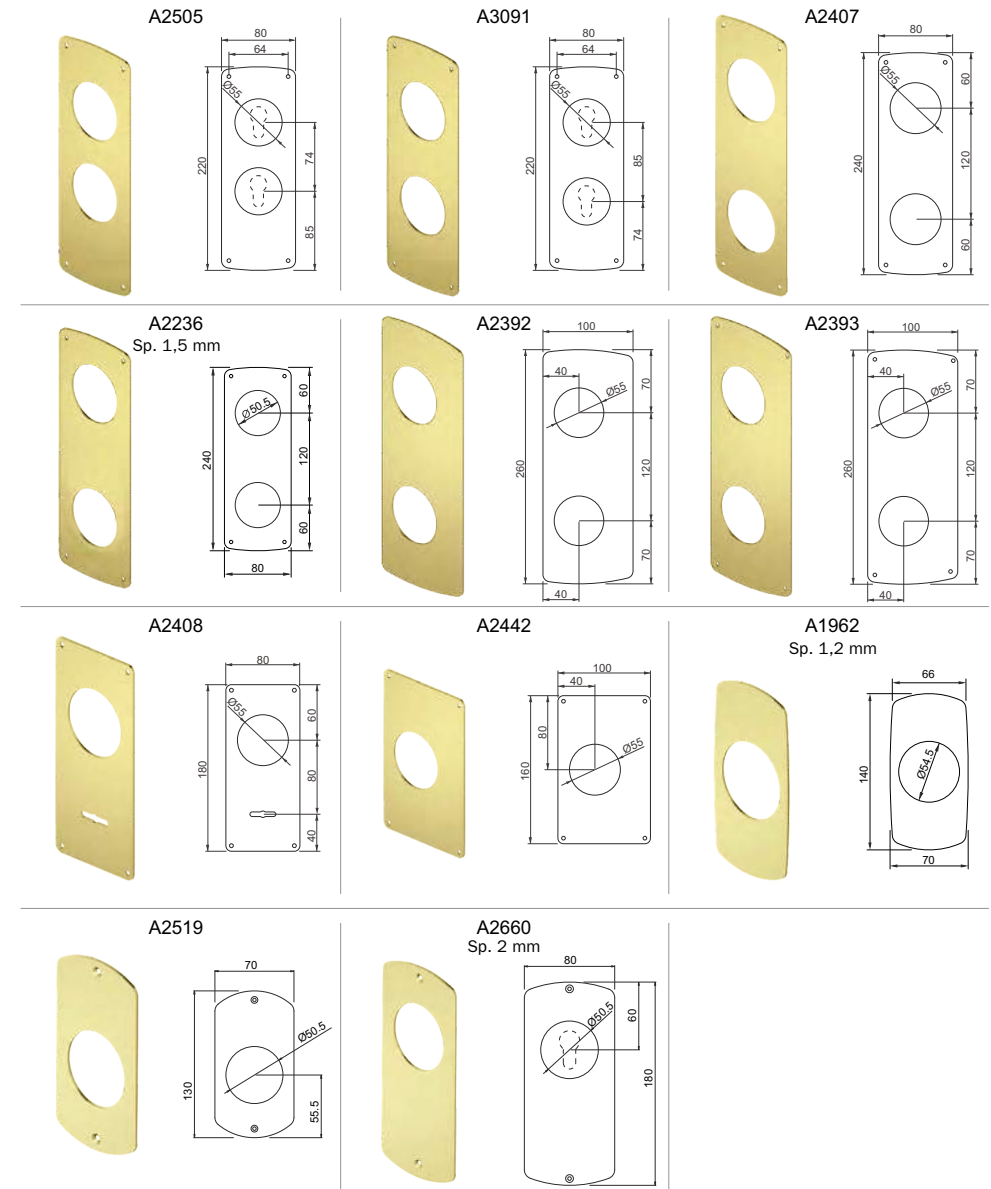
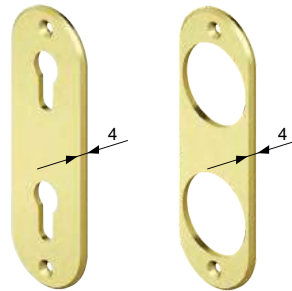
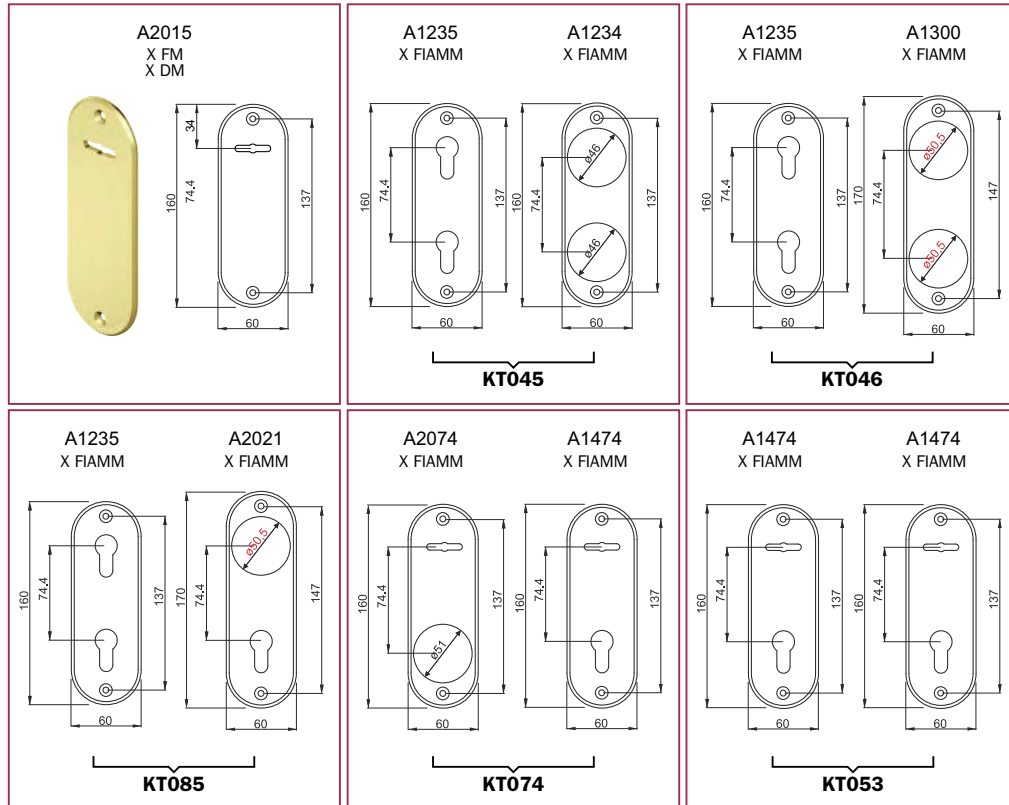

FINITURE / FINISHES

- C** Cromo lucido
Bright Chrome
- T** Inox satinato
Stainless steel
- B** Bronzo
Bronze
- L** Ottone lucido
Bright Brass
- 2** PVD Ottone
PVD Brass

FINITURE / FINISHES

- C** Cromo lucido
Bright Chrome
- T** Inox satinato
Stainless steel
- B** Bronzo
Bronze
- 2** PVD Ottone
PVD Brass

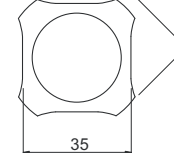
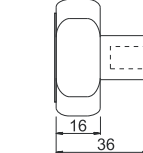
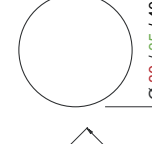
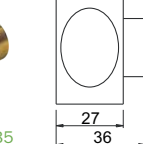
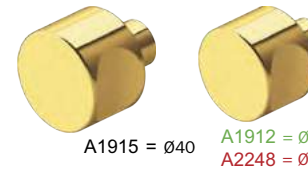
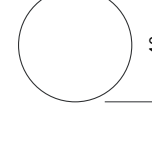
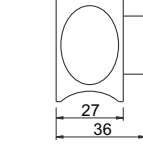
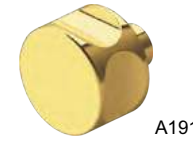
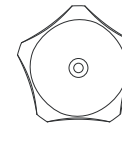
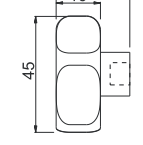
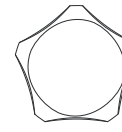
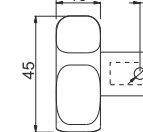
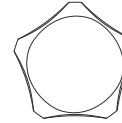
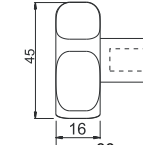
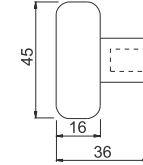
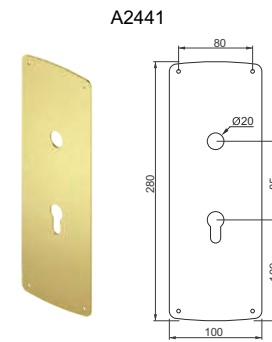
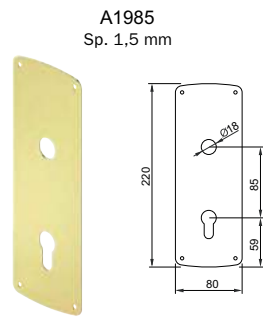
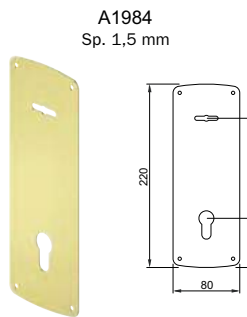
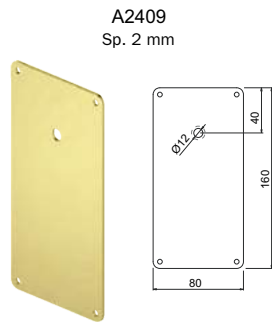
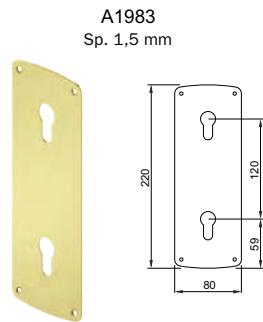
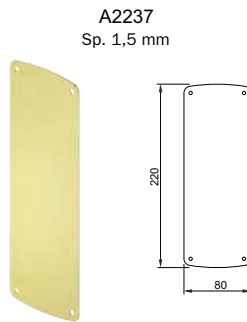
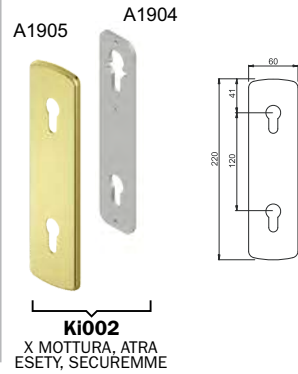
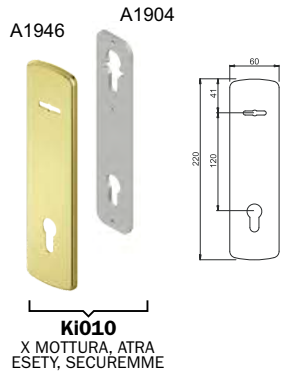
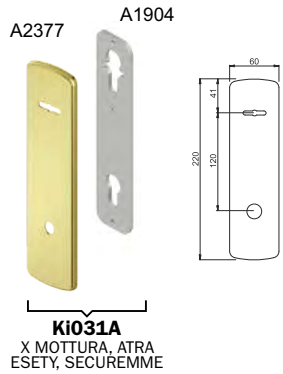

FINITURE / FINISHES

- C** Cromo lucido / Bright Chrome
- T** Cromo satinato / Satin Chrome
- IT** Inox satinato / Stainless steel
- B** Bronzo / Bronze
- L** Ottone lucido / Bright Brass
- 2** PVD Ottone / PVD Brass

FINITURE / FINISHES

- C** Cromo lucido / Bright Chrome
- T** Cromo satinato / Satin Chrome
- B** Bronzo / Bronze
- 2** PVD Ottone / PVD Brass
- BS** Bronzo satinato / Satin Bronze

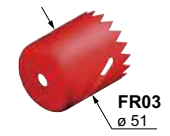
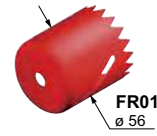
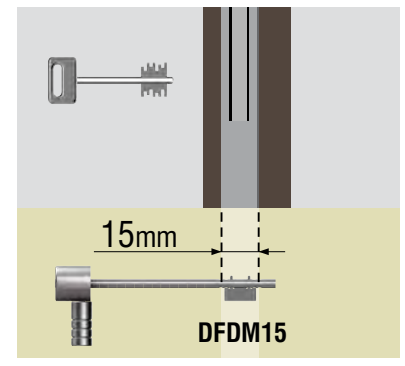
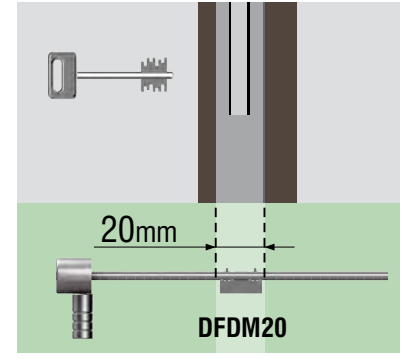
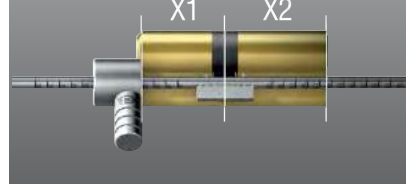
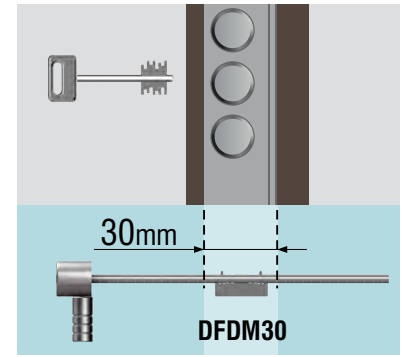
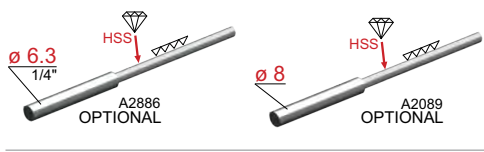
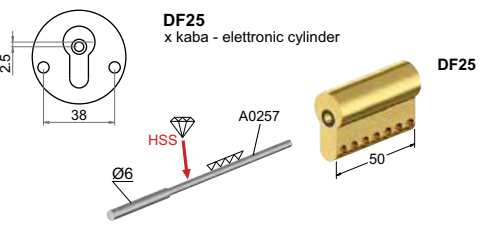
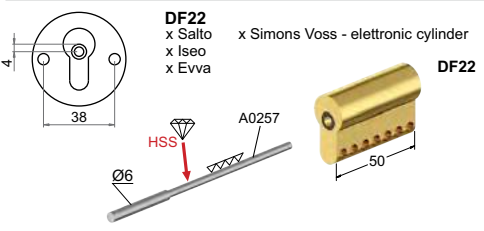
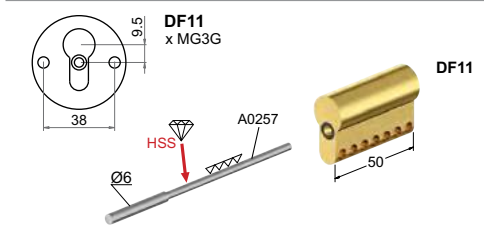
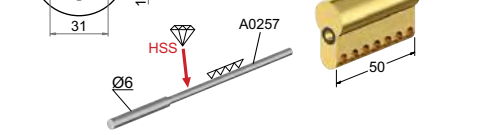
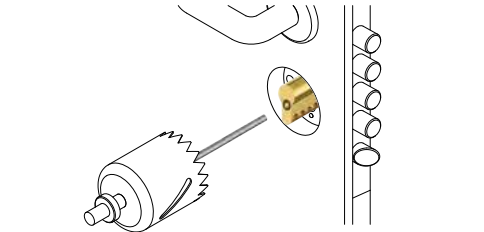
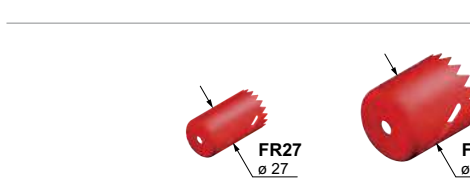
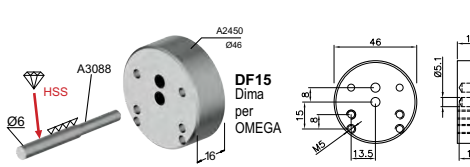
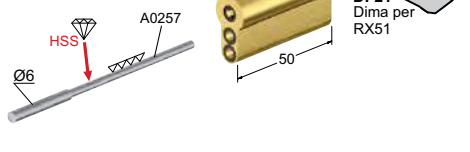
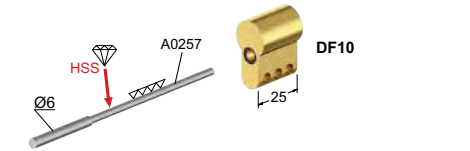
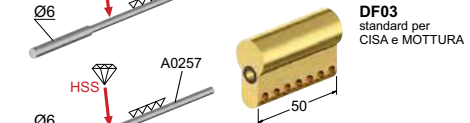
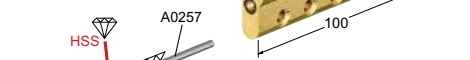

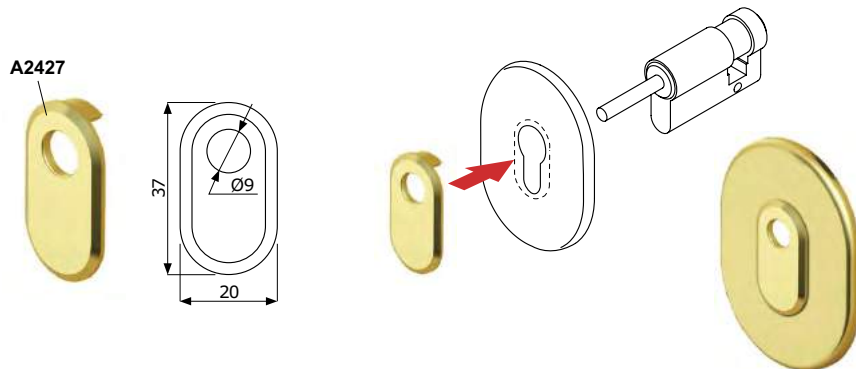
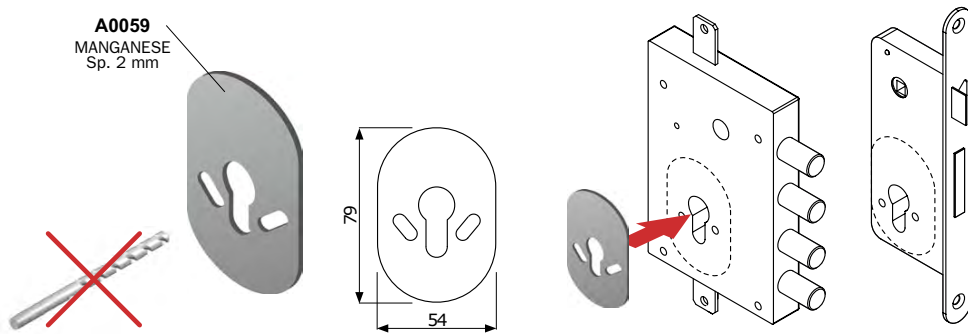
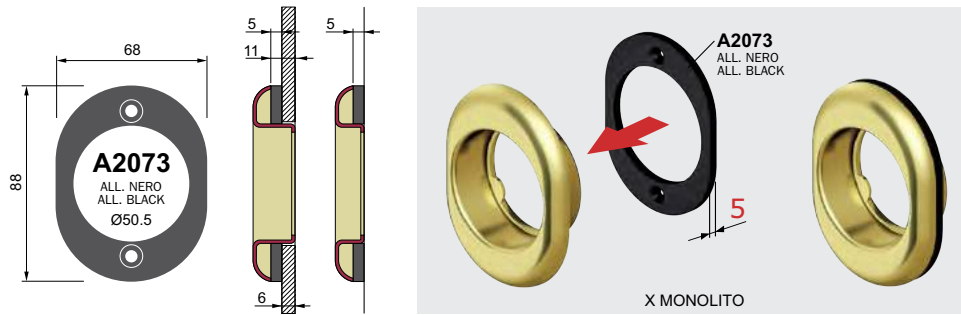

FINITURE / FINISHES

- C Cromo lucido / Bright Chrome
- B Bronzo / Bronze
- L Ottone lucido / Bright Brass
- T Cromo satinato / Satin Chrome
- N Nero / Black

Ø 50	UNIVERSAL			
	A1565 1mm		Ø50	
	A1566 2mm			
	A2755 5mm		Ø50	
	A2756 10mm		Ø50	
	A2763 15mm		Ø50	
Ø 45	A2578 2mm		Ø8 Ø50	
	X OMEGA			
	A3375 2mm		Ø27 Ø38	
Ø 44	X FIAM		Ø6 Ø45	
	A0592 1mm			
Ø 42	A0591 2mm			
	X TOTOR		Ø44	
Ø 40	A3185 5mm		Ø6 Ø42	
	X ESETY X ATRA X CR		3.5 Ø40	



SERVICE KIT
430x290x55 mm
ACCIAIO INOX SATINATO



SERVICE KIT mini
328x258x52 mm

18061205 20 pz Vite M6x120 testa svasata piana con cava esagonale CLASSE 10.9	18060705 20 pz Vite M6x70 testa svasata piana con cava esagonale CLASSE 10.9	10060405 10 pz Vite M6x40 testa cilindrica con cava esagonale CLASSE 12.9	28030052 20 pz Grano M3x5 con cava esagonale	25060065 20 pz Grano M6x6 con cava esagonale	25060405 20 pz Grano M6x40 con cava esagonale
18061005 20 pz Vite M6x100 testa svasata piana con cava esagonale CLASSE 10.9	18060605 20 pz Vite M6x60 testa svasata piana con cava esagonale CLASSE 10.9	10050405 10 pz Vite M5x40 testa cilindrica con cava esagonale CLASSE 8.8	31030125 100 pz Vite autofilettante Ø 3x12 testa svasata piana a croce BRONZO	31030125 100 pz Vite autofilettante Ø 3x12 testa svasata piana a croce ORO	
10061205 20 pz Vite M6x120 testa cilindrica con cava esagonale CLASSE 12.9	10060705 20 pz Vite M6x70 testa cilindrica con cava esagonale CLASSE 12.9	10080405 10 pz Vite M8x40 testa cilindrica con cava esagonale	31030125 100 pz Vite autofilettante Ø 3x12 testa svasata piana a croce ZINCATA	31040165 100 pz Vite autofilettante Ø 4x16 testa svasata piana a croce ORO	
10061005 20 pz Vite M6x100 testa cilindrica con cava esagonale CLASSE 12.9	10060605 20 pz Vite M6x60 testa cilindrica con cava esagonale CLASSE 12.9	13060200 10 pz Vite M6x20 testa cilindrica quadro sotto testa	30 30 pz Dadi esagonali M6	30 30 pz Rondella x M6	20 20 pz Sfera Ø 4,8 acciaio 10 10 pz A0716 Pin blocco SG 10 10 pz O-Ring Ø 41x1,78
10060805 20 pz Vite M6x80 testa cilindrica con cava esagonale CLASSE 12.9	10060505 20 pz Vite M6x50 testa cilindrica con cava esagonale CLASSE 12.9	A1566 10 pz Ø 50x2,5 Spessore universale	A2427N 12 pz Adattatore codolo (Nero)	A1056 10 pz Ø 40x2,5 Spessore universale	

18061205 10 pz Vite M6x120 CLASSE 10.9	10060805 10 pz Vite M6x80 CLASSE 12.9				
10061205 10 pz Vite M6x120 CLASSE 12.9	10061005 10 pz Vite M6x100 CLASSE 12.9				
A2578 10 pz Spessore m 8 Ø 50x2,5	18061005 10 pz Vite M6x100 CLASSE 10.9	10060705 10 pz Vite M6x70 CLASSE 12.9	10060605 10 pz Vite M6x60 CLASSE 12.9	10060505 10 pz Vite M6x50 CLASSE 12.9	
10 10 pz O-Ring Ø 41x1,78	A1566 10 pz Spessore universale Ø 50x2,5	10080405 10 pz Vite M8x40	31030125 4 pz Vite Ø 3x12 ORO	31030125 4 pz Vite Ø 3x12 BRONZO	31030125 4 pz Vite Ø 3x12 ZINCATA

- C Cromo lucido
Bright Chrome
- T Cromo satinato
Satin Chrome
- B Bronzo
Bronze
- 85 Bronzo satinato
Satin Bronze
- L Ottone lucido
Bright Brass
- 2 PVD Ottone
PVD Brass
- 11 Inox satinato
Stainless steel
- 9 Oro anodizzato
Anodized Gold
- 6 Argento anodizzato
Anodized Silver

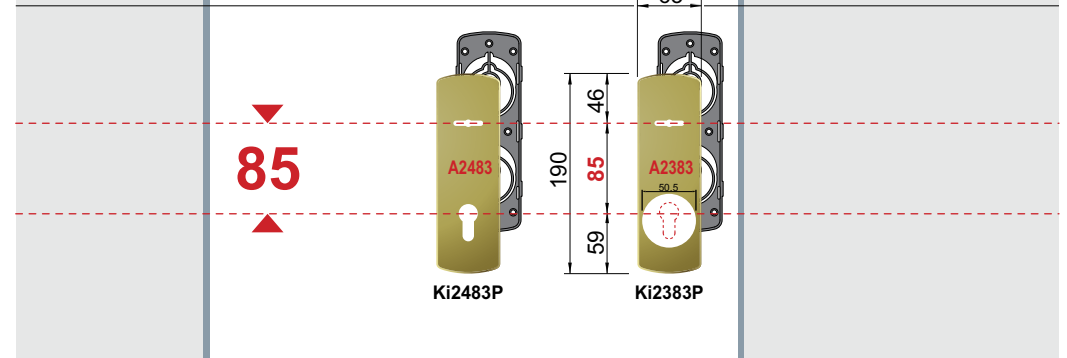
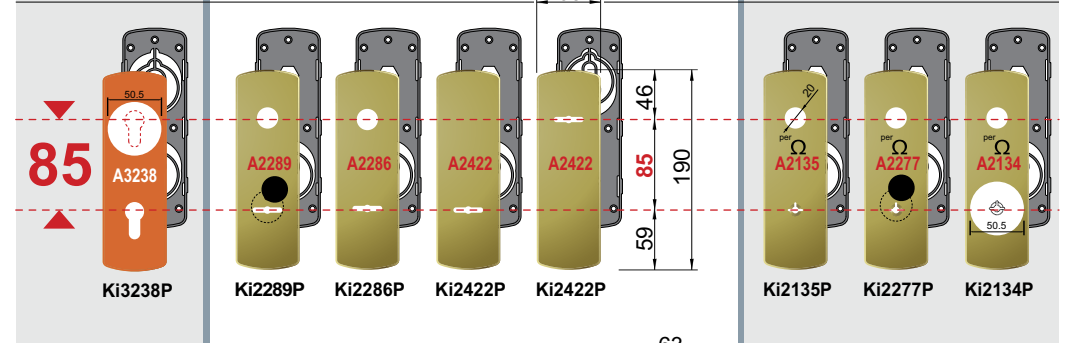
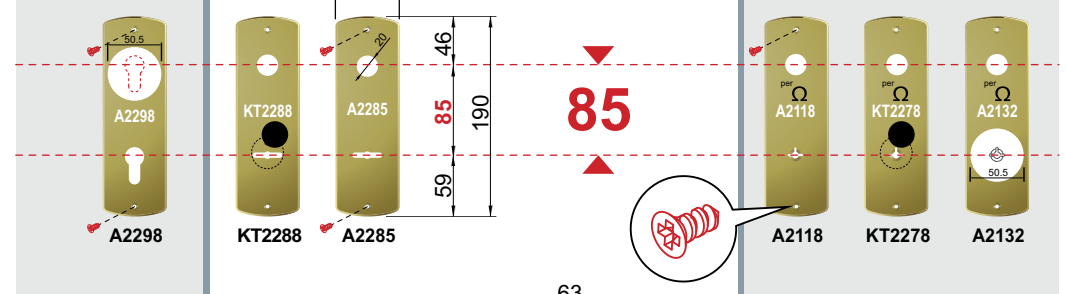
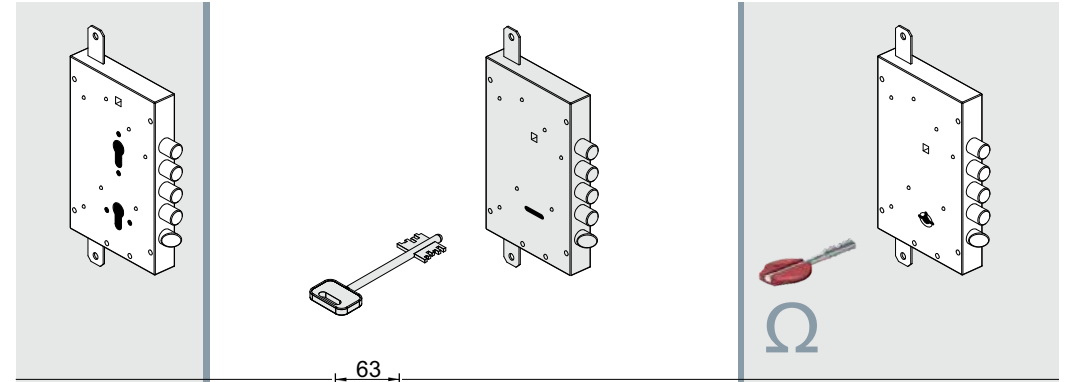
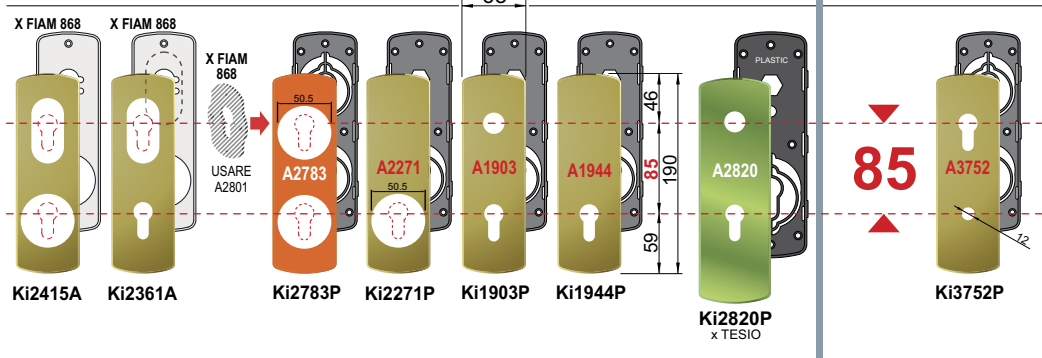
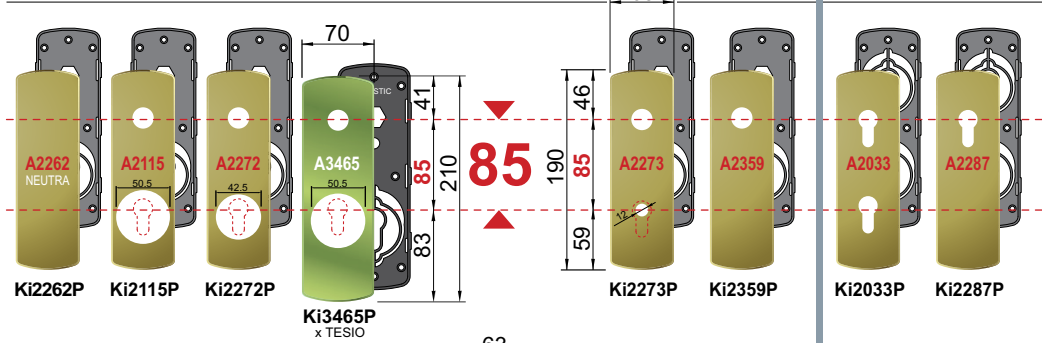
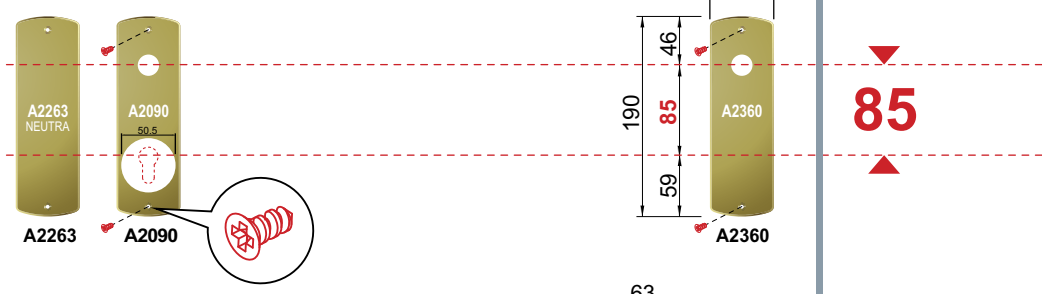
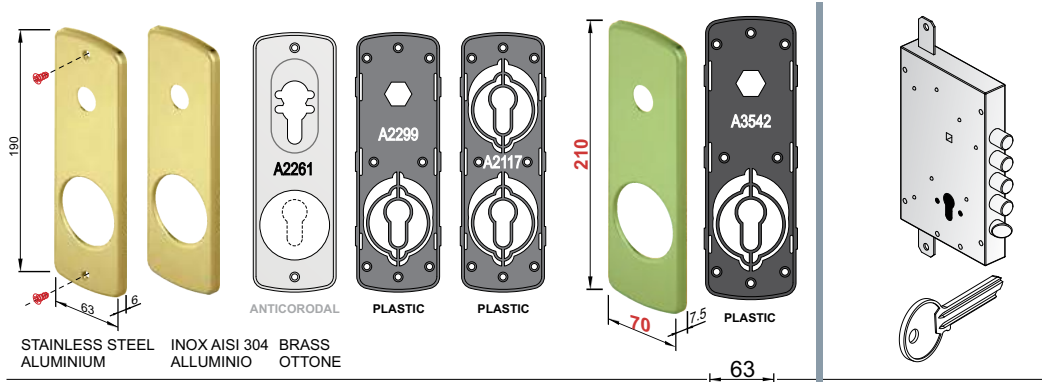

FINITURE / FINISHES

- | | | |
|------------------------------------|--------------------------------------|---|
| (C) Cromo lucido
Bright Chrome | (BS) Bronzo satinato
Satin Bronze | (II) Inox satinato
Stainless steel |
| (T) Cromo satinato
Satin Chrome | (L) Ottone lucido
Bright Brass | (9) Oro anodizzato
Anodized Gold |
| (B) Bronzo
Bronze | (2) PVD Ottone
PVD Brass | (6) Argento anodizzato
Anodized Silver |

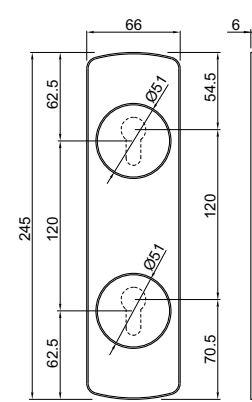
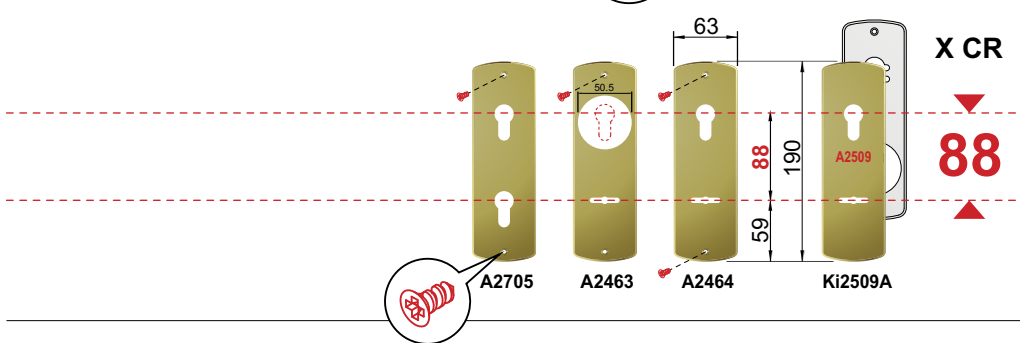
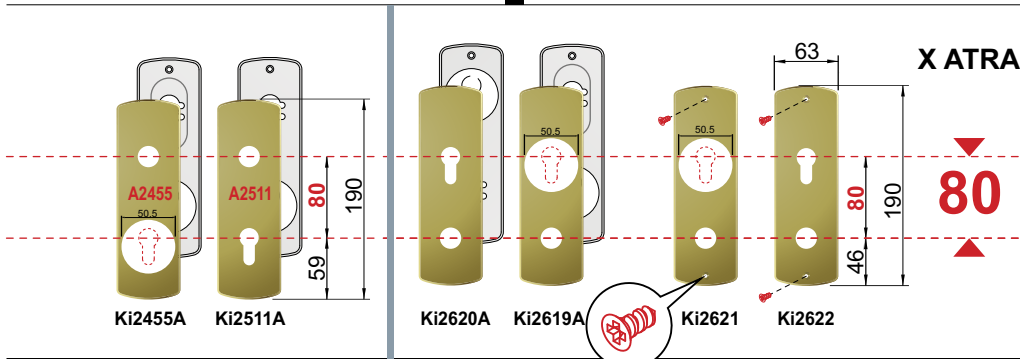
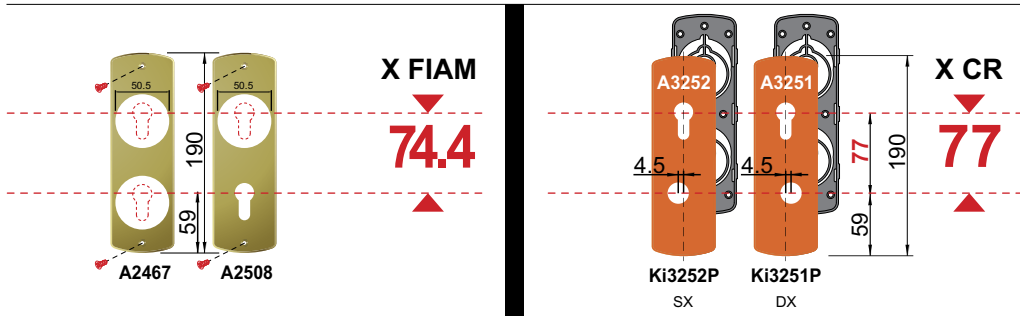
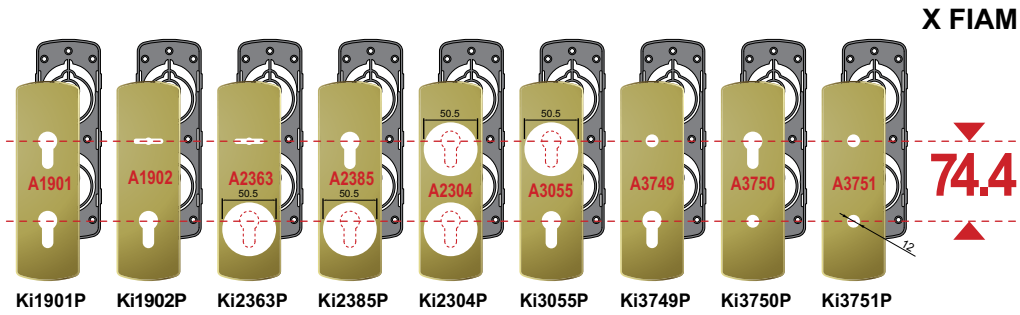
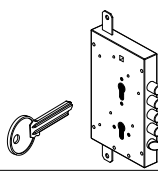

- FINITURE FINISHES
- | | | |
|------------------------------------|--------------------------------------|---|
| (C) Cromo lucido
Bright Chrome | (BS) Bronzo satinato
Satin Bronze | (II) Inox satinato
Stainless steel |
| (T) Cromo satinato
Satin Chrome | (L) Ottone lucido
Bright Brass | (9) Oro anodizzato
Anodized Gold |
| (B) Bronzo
Bronze | (2) PVD Ottone
PVD Brass | (6) Argento anodizzato
Anodized Silver |

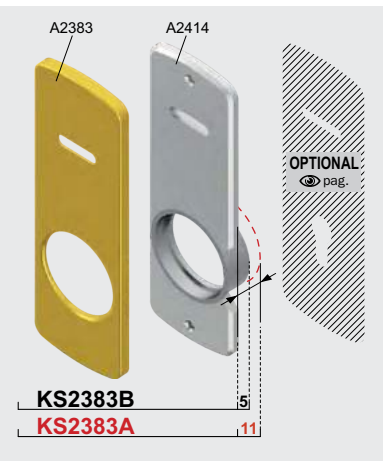
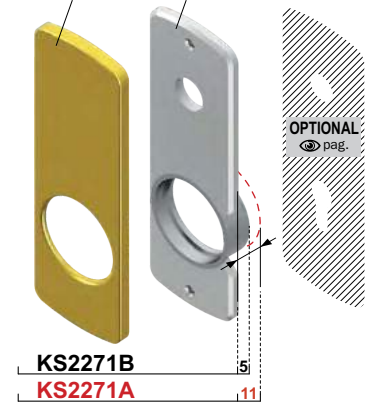
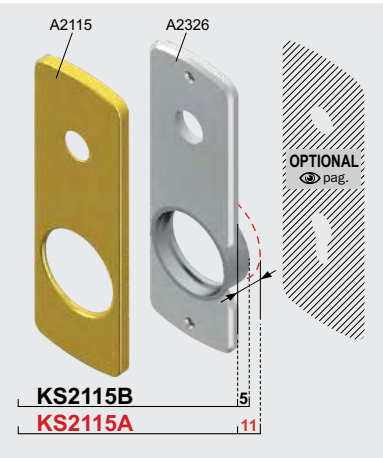
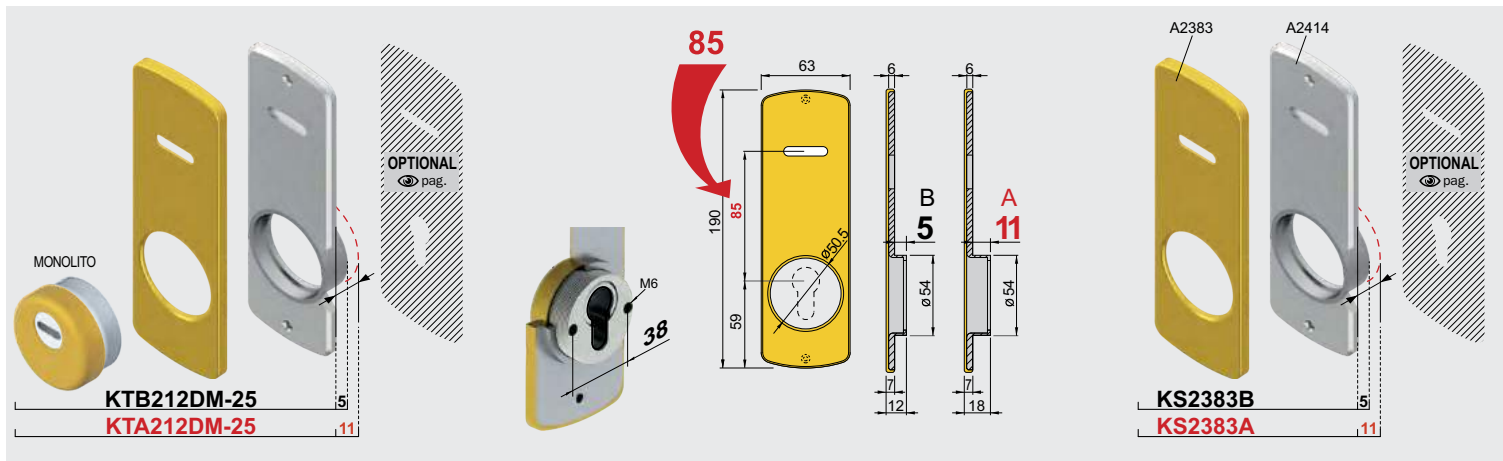
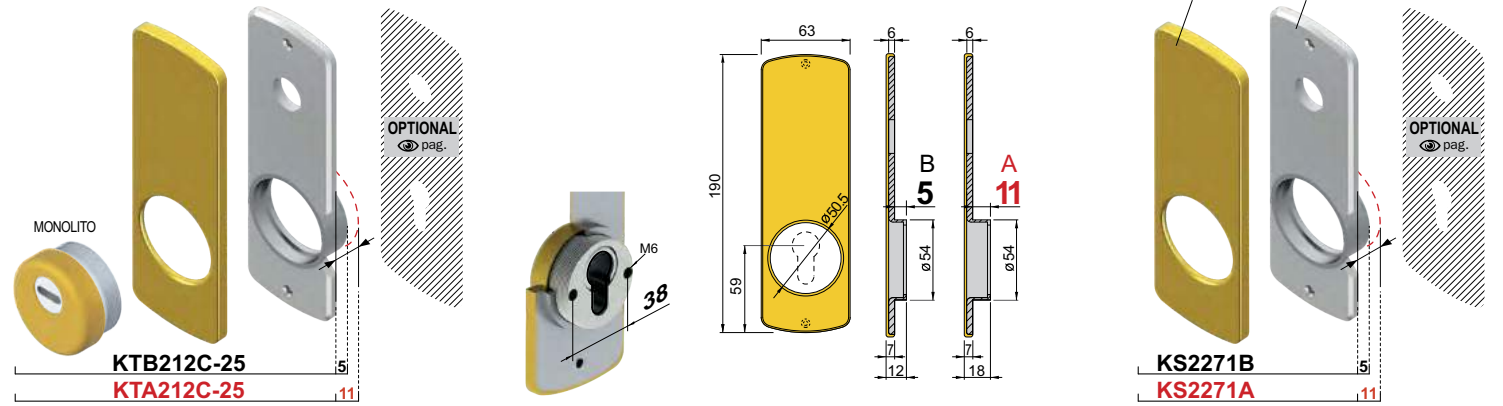
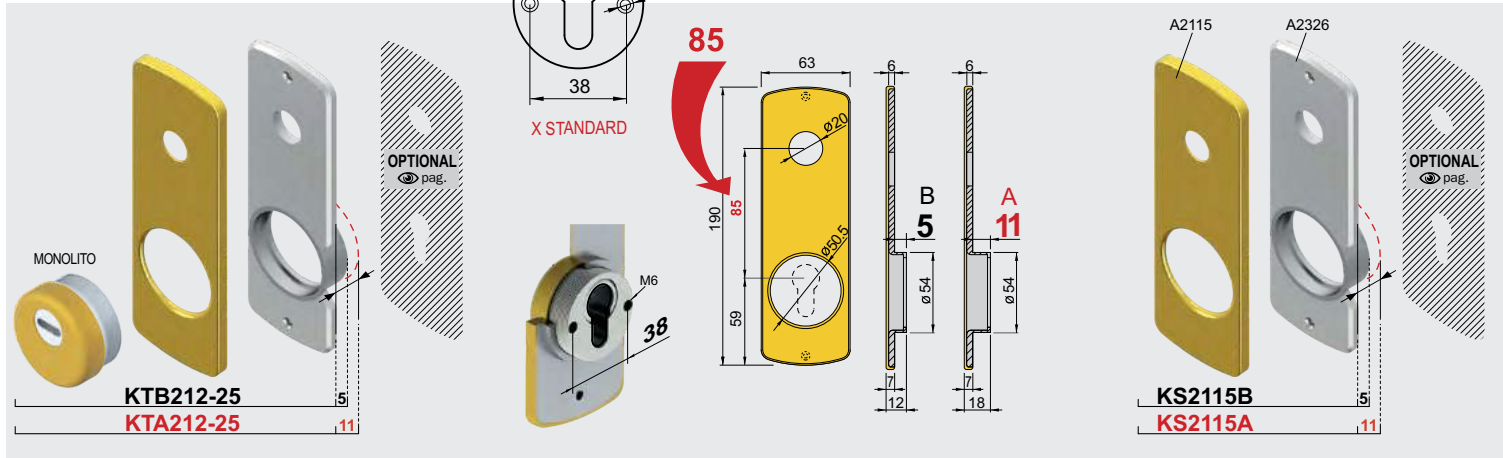

FILETTATO	Ø	H	M6	pag.	X OMEGA	FINITURE FINISHES
DIAMOND	50	25	38	S1		C Cromo lucido T Cromo satinato B Bronzo 2 PVD Ottono TT Ottono satinato BS Bronzo satinato IT Inox satinato
MONOLITO		20	25	35	45	C Cromo lucido T Cromo satinato B Bronzo 2 PVD Ottono TT Ottono satinato BS Bronzo satinato IT Inox satinato
MONOLITO		20	25	35	45	C Cromo lucido T Cromo satinato B Bronzo 2 PVD Ottono TT Ottono satinato BS Bronzo satinato IT Inox satinato
MAG ROUND		20	25	35	45	C Cromo lucido T Cromo satinato B Bronzo 2 PVD Ottono TT Ottono satinato BS Bronzo satinato IT Inox satinato
MRM23		20	25	35	45	C Cromo lucido T Cromo satinato B Bronzo 2 PVD Ottono TT Ottono satinato BS Bronzo satinato IT Inox satinato
MAG3G		20	25	35		C Cromo lucido T Cromo satinato 2 PVD Ottono TT Ottono satinato BS Bronzo satinato IT Inox satinato
MAG4G		20	25	35		C Cromo lucido T Cromo satinato 2 PVD Ottono TT Ottono satinato BS Bronzo satinato IT Inox satinato

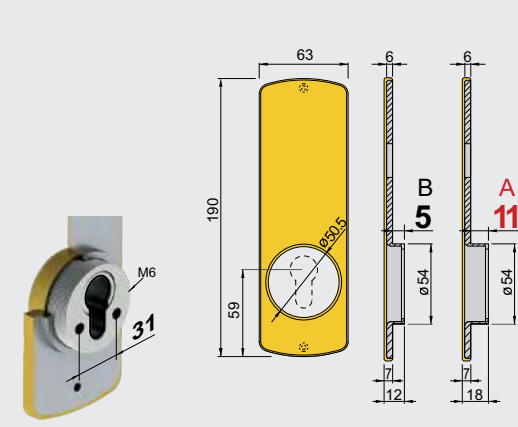
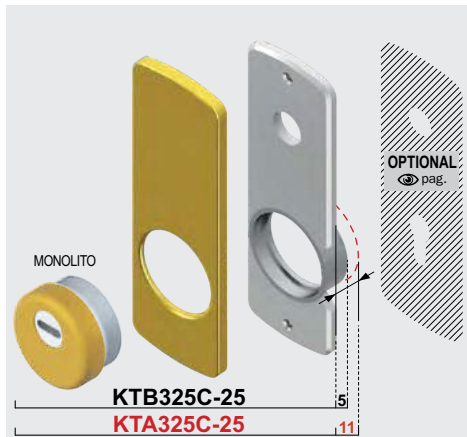
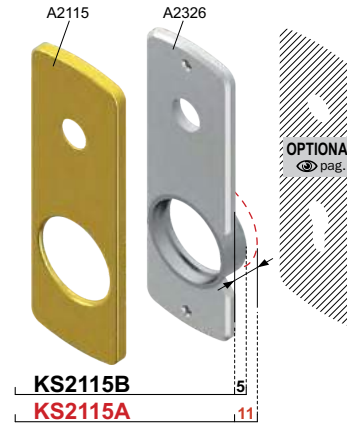
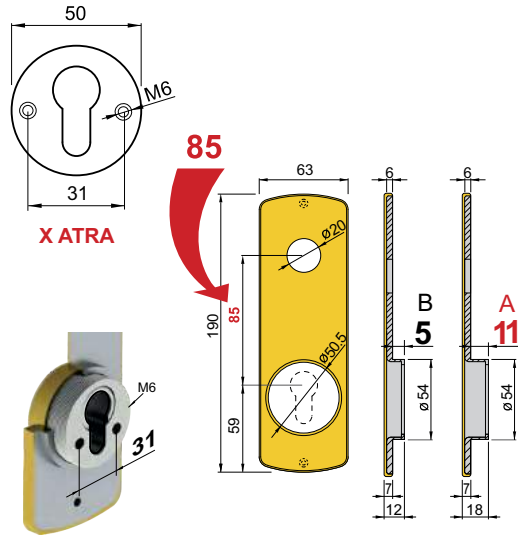
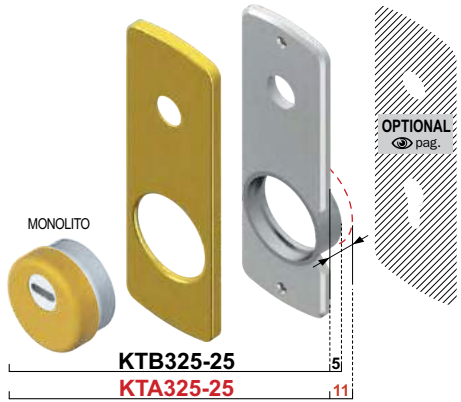

Model	Finish	Code
FILETTATO Ø 50 PAG. 12	XATRA pag. S1	MA3535
	XATRA pag. D1	
	DIAMOND	
	DIAMOND	
	DIAMOND	
	DIAMOND	
	DIAMOND	
	DIAMOND	
	DIAMOND	
	DIAMOND	
MONOLITO KRIPTON PAG. 22	Cromo lucido	MA3634
	Cromo satinato	MA3526
	Bronzo	MA3625
	PVD Ottone	MA3627
	Ottone satinato	
MONOLITO PAG. 32	Cromo lucido	MA2372
	Cromo satinato	MA2731
	Bronzo	MA1928
	PVD Ottone	
	Ottone satinato	
MAG ROUND PAG. 74	Cromo lucido	MR13920..
	Cromo satinato	MR13925..
	Bronzo	MR13935..
	PVD Ottone	
	Ottone satinato	
MRM23 PAG. 68	Cromo lucido	MR13320..
	Cromo satinato	MR13325..
	Bronzo	MR13335..
	PVD Ottone	
	Ottone satinato	
MAG3G PAG. 62	Cromo lucido	3G320..
	Cromo satinato	3G325..
	PVD Ottone	3G335..
	Ottone satinato	
MAG4G PAG. 60	Cromo lucido	4G320..
	Cromo satinato	4G325..
	PVD Ottone	4G335..
	Ottone satinato	

- FINITURE FINISHES**
- C Cromo lucido Bright Chrome
 - T Cromo satinato Satin Chrome
 - B Bronzo Bronze
 - 2 PVD Ottone PVD Brass
 - TT Ottone satinato Satin Brass
 - BS Bronzo satinato Satin Bronze
 - IT Inox satinato Stainless steel

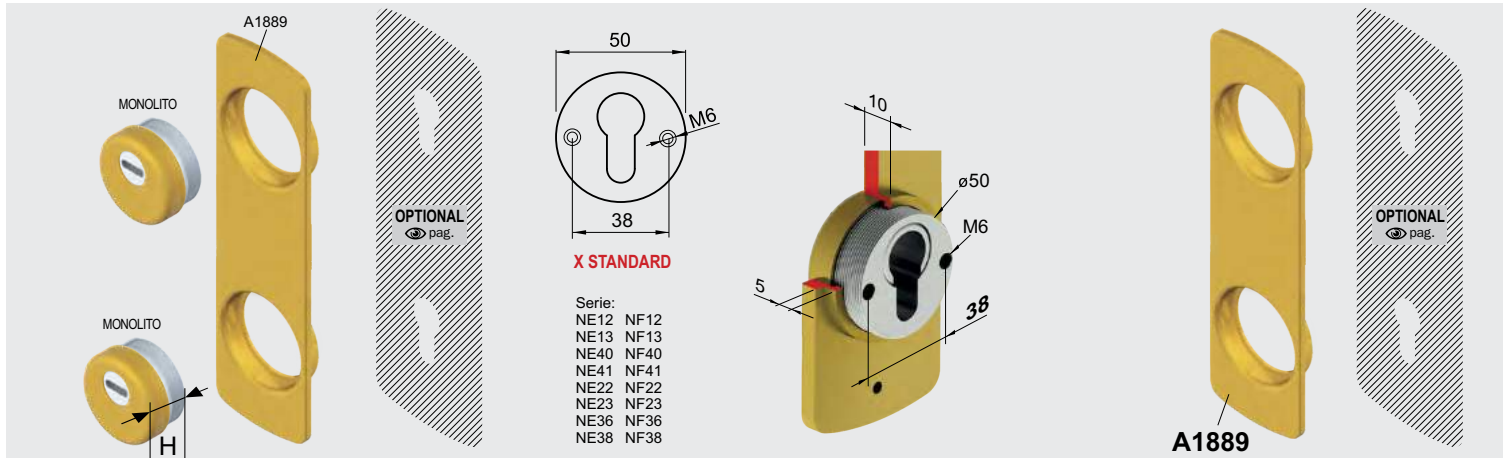

X STANDARD

Serie:
NE12 NF12
NE13 NF13
NE40 NF40
NE41 NF41
NE22 NF22
NE23 NF23
NE36 NF36
NE38 NF38

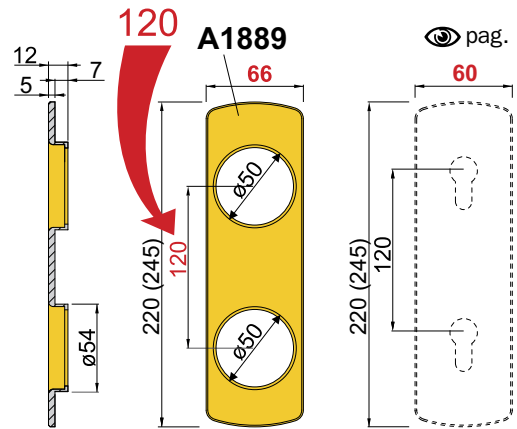
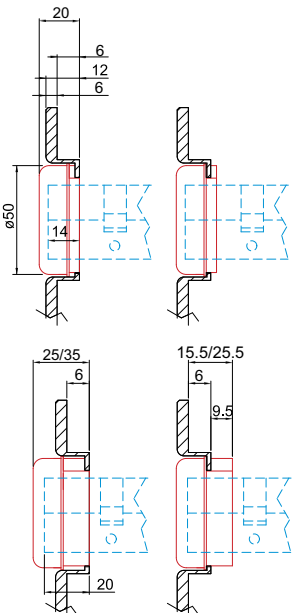

Model	Height (mm)	Code	Code	FINITURE FINISHES
FILETTATO Ø 50 H				
DIAMOND PAT. PEND. PAG 12	25	MA3536		C Cromo lucido T Cromo satinato B Bronzo Z PVD Ottonne TT Ottone satinato BS Bronzo satinato IT Inox satinato
MONOLITO KRIPTON PAT. PEND. PAG 22	20 25 35 45	MA3633 MA3527 MA3626 MA3628		C Cromo lucido T Cromo satinato B Bronzo Z PVD Ottonne TT Ottone satinato BS Bronzo satinato IT Inox satinato
MONOLITO PAT. PEND. PAG 32	20 25 35 45	MA2371 MA2665 MA1927 MA2702		C Cromo lucido T Cromo satinato B Bronzo Z PVD Ottonne TT Ottone satinato BS Bronzo satinato IT Inox satinato
MAG ROUND PAT. PEND. PAG 74	20 25 35 45	MR12920 MR12925 MR12935 MR12945	MR29820 MR29825	C Cromo lucido T Cromo satinato B Bronzo Z PVD Ottonne TT Ottone satinato BS Bronzo satinato IT Inox satinato
MRM23 PAT. PEND. PAG 68	20 25 35 45	MR12320 MR12325 MR12335 MR12345	MR23820 MR23825	C Cromo lucido T Cromo satinato B Bronzo Z PVD Ottonne TT Ottone satinato BS Bronzo satinato IT Inox satinato
MAG3G PAT. PEND. PAG 62	20 25 35	3G220 3G225 3G235	3G820	C Cromo lucido T Cromo satinato B Bronzo Z PVD Ottonne TT Ottone satinato BS Bronzo satinato IT Inox satinato
MAG4G PAT. PEND. PAG 60	20 25 35	4G220 4G225 4G235	4G825	C Cromo lucido T Cromo satinato B Bronzo Z PVD Ottonne TT Ottone satinato BS Bronzo satinato IT Inox satinato

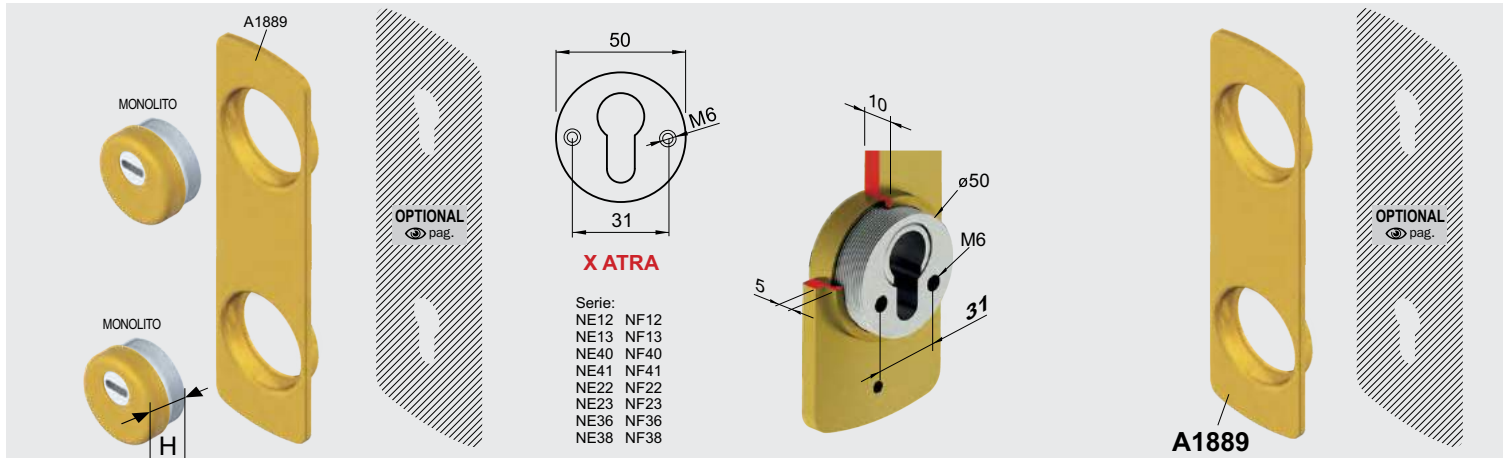

- 20 **KT218ATR..**
- 25 **KT225ATR..**
- 35 **KT235ATR..**

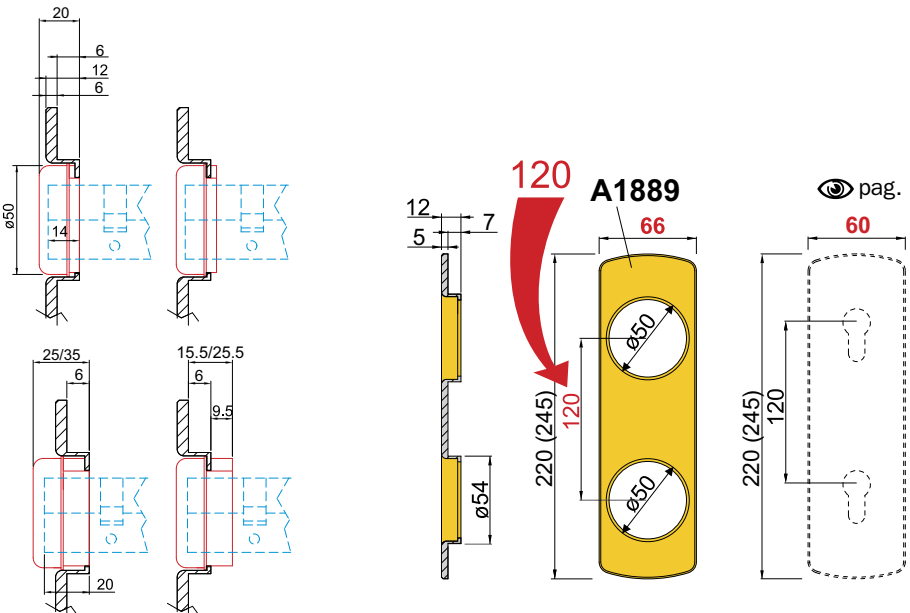

Model	Finish	Code
FILETTATO Ø 50 H	X ATR A	pag. S1
		D1
DIAMOND PAT. PEND. PAG 12	25	MA3535
	20	MA3634
MONOLITO KRIPTON PAT. PEND. PAG 22	25	MA3526
	35	MA3625
	45	MA3627
	20	MA2372
MONOLITO PAT. PEND. PAG 32	25	MA2731
	35	MA1928
	45	
MAG ROUND PAT. PEND. PAG 74	20	MR13920..
	25	MR13925..
	35	MR13935..
	45	
MRM23 PAT. PEND. PAG 68	20	MR13320..
	25	MR13325..
	35	MR13335..
MAG3G PAT. PEND. PAG 62	20	3G320..
	25	3G325..
	35	3G335..
MAG4G PAT. PEND. PAG 60	20	4G320..
	25	4G325..
	35	4G335..

- FINITURE FINISHES**
- C Cromo lucido Bright Chrome
 - T Cromo satinato Satin Chrome
 - B Bronzo Bronze
 - Z PVD Ottonne PVD Brass
 - TT Ottone satinato Satin Brass
 - BS Bronzo satinato Satin Bronze
 - IT Inox satinato Stainless steel

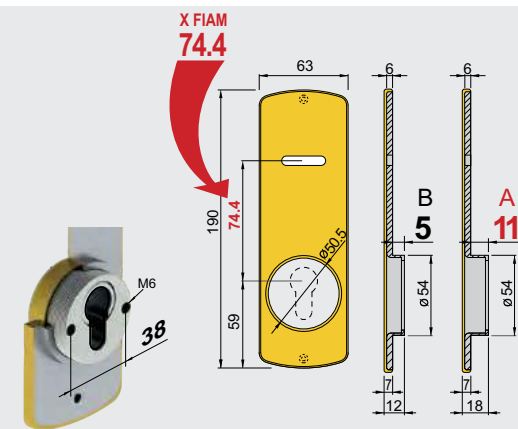
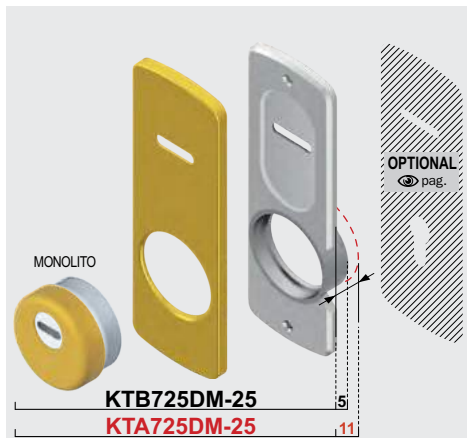
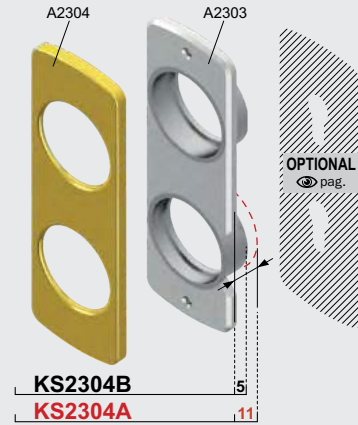
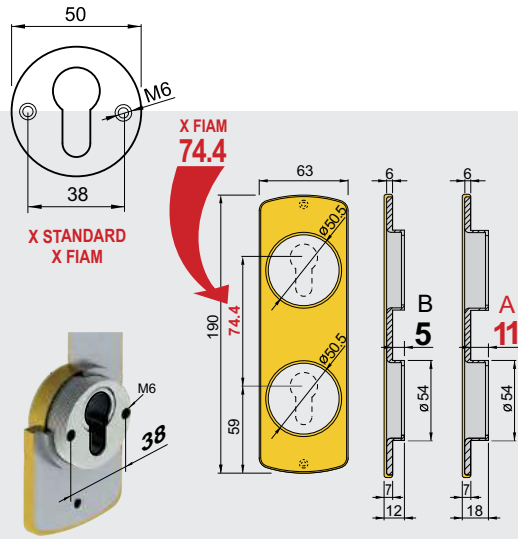
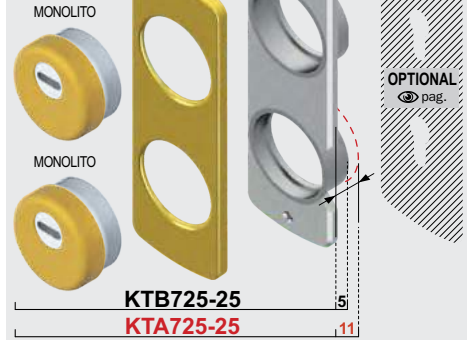

Model	Finish	Accessories	Notes
FILETTATO Ø 50		pag. S1, D1	X OMEGA
DIAMOND PAT. PEND. PAG 12		25	MA3536
MONOLITO KRIPTON PAT. PEND. PAG 22		20, 25, 35, 45	MA3633, MA3527, MA3626, MA3628
MONOLITO PAT. PEND. PAG 32		20, 25, 35, 45	MA2371, MA2665, MA1927, MA2702
MAG ROUND PAT. PEND. PAG 74		20, 25, 35, 45	MR12920, MR12925, MR12935, MR12945, MR29820, MR29825
MRM23 PAT. PEND. PAG 68		20, 25, 35, 45	MR12320, MR12325, MR12335, MR12345, MR23820, MR23825
MAG3G PAT. PEND. PAG 62		20, 25, 35	3G220, 3G225, 3G235, 3G820
MAG4G PAT. PEND. PAG 60		20, 25, 35	4G220, 4G225, 4G235, 4G825

Model	Finish
FILETTATO	Cromo lucido, Cromo satinato, Bronzo, PVD Otone, Otone satinato, Bronzo satinato, Inox satinato, Stainless steel
DIAMOND	Cromo lucido, Cromo satinato, Bronzo, PVD Otone, Otone satinato, Bronzo satinato, Inox satinato, Stainless steel
MONOLITO KRIPTON	Cromo lucido, Cromo satinato, Bronzo, PVD Otone, Otone satinato, Bronzo satinato, Inox satinato, Stainless steel
MONOLITO	Cromo lucido, Cromo satinato, Bronzo, PVD Otone, Otone satinato, Bronzo satinato, Inox satinato, Stainless steel
MAG ROUND	Cromo lucido, Cromo satinato, Bronzo, PVD Otone, Otone satinato, Bronzo satinato, Inox satinato, Stainless steel
MRM23	Cromo lucido, Cromo satinato, Bronzo, PVD Otone, Otone satinato, Bronzo satinato, Inox satinato, Stainless steel
MAG3G	Cromo lucido, Cromo satinato, Bronzo, PVD Otone, Otone satinato, Bronzo satinato, Inox satinato, Stainless steel
MAG4G	Cromo lucido, Cromo satinato, Bronzo, PVD Otone, Otone satinato, Bronzo satinato, Inox satinato, Stainless steel

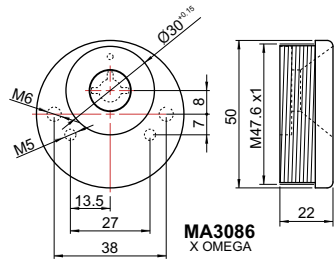

X Ω

MA3086
X OMEGA

A2134

KS2115A
KS2115B

ACCIAIO
STEEL

A2326

AS2326B

AS2326A

A2301
A2302

5

11

X MOTTURA / CR

KS2440A
KS2440B

ACCIAIO
STEEL

MONOLITO

MONOLITO

25

5

11

AS2439B

AS2439A

KTB10800

KTA10800

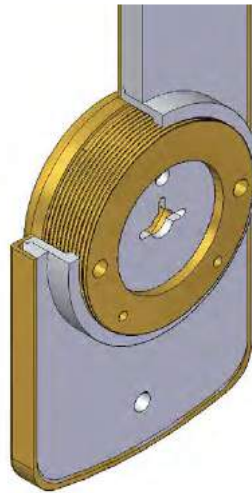
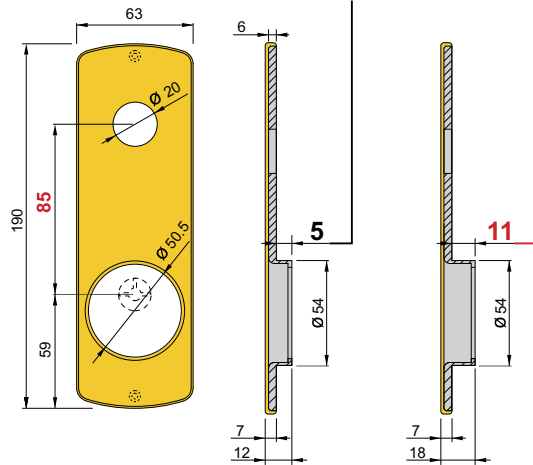

KTB425-25..

KTA425-25..

X MOTTURA / CR

88

88

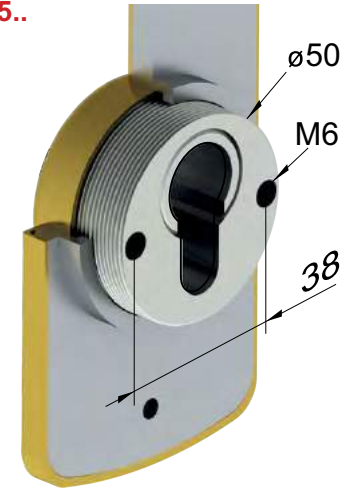
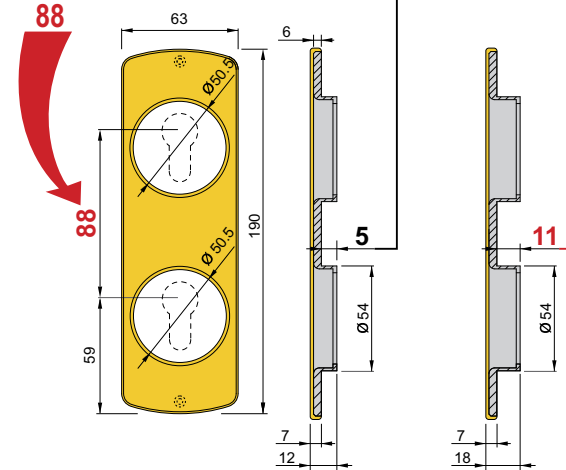

FINITURE / FINISHES

- C Cromo lucido / Bright Chrome
- T Cromo satinato / Satin Chrome
- B Bronzo / Bronze
- 12 Ottone Zapponato / Satin Brass
- IT Inox satinato / Stainless steel
- 2 PVD Ottone / PVD Brass
- BS Bronzo satinato / Satin Bronze

FINITURE / FINISHES

- C Cromo lucido / Bright Chrome
- T Cromo satinato / Satin Chrome
- B Bronzo / Bronze
- 12 Ottone Zapponato / Satin Brass
- IT Inox satinato / Stainless steel
- 2 PVD Ottone / PVD Brass
- BS Bronzo satinato / Satin Bronze

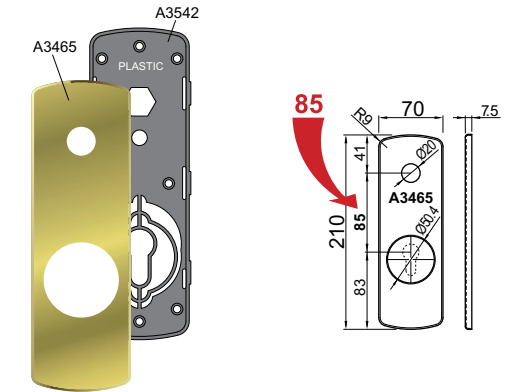
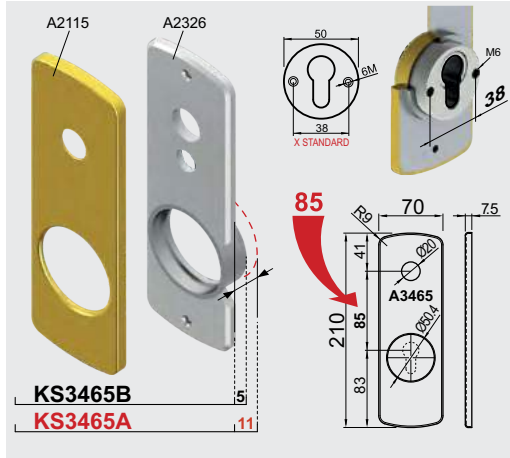

Ki3465P X TESIO

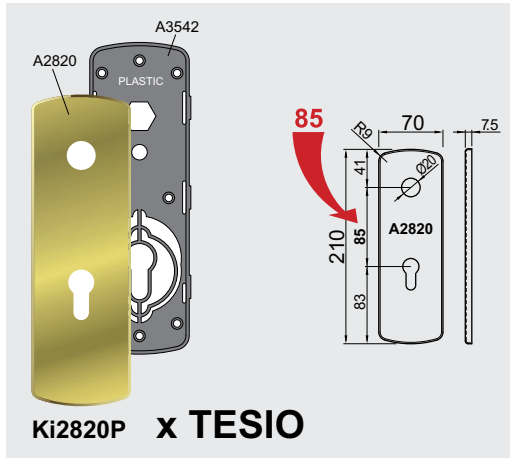

Ki2820P X TESIO

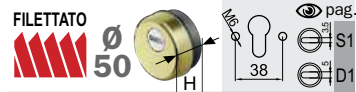

FINITURE FINISHES

DIAMOND

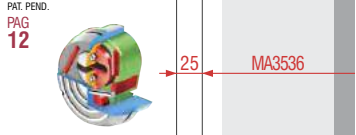

MONOLITO KRIPTON

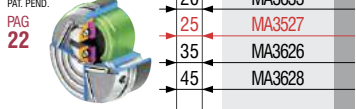

MONOLITO



MAG ROUND

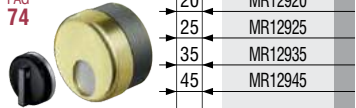

MRM23



MAG3G

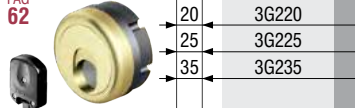

MAG4G

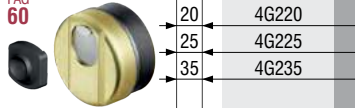

- | | | |
|----|-----------------|-----------------|
| C | Cromo lucido | Bright Chrome |
| T | Cromo satinato | Satin Chrome |
| B | Bronzo | Bronze |
| Z | PVD Ottono | PVD Brass |
| TT | Ottono satinato | Satin Brass |
| BS | Bronzo satinato | Satin Bronze |
| IT | Inox satinato | Stainless steel |



MONOLITO

KT2108-25D1 X OMEGA

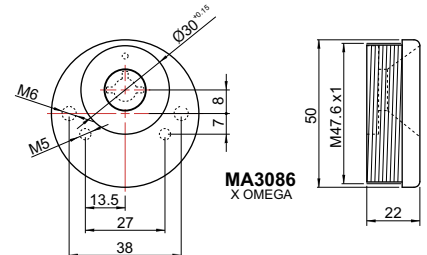

MA3086 X OMEGA

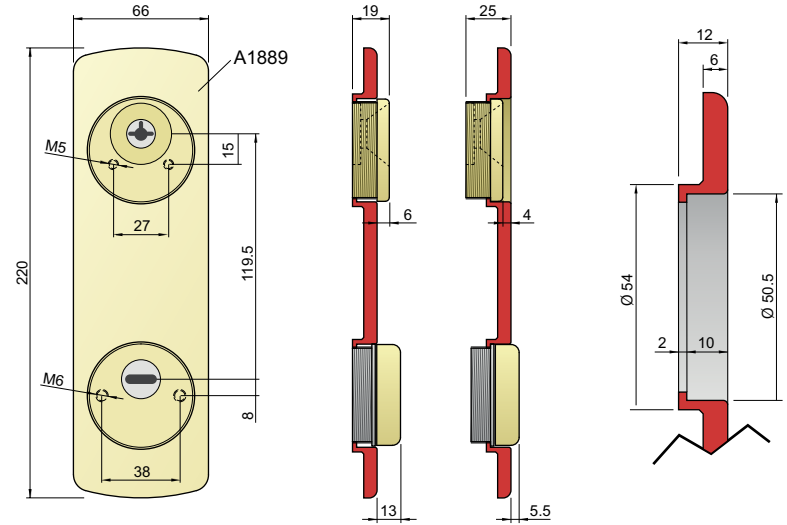
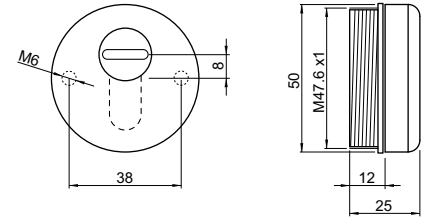

FINITURE / FINISHES

- | | | |
|---|----------------|--------------|
| T | Cromo satinato | Satin Chrome |
| Z | PVD Ottono | PVD Brass |
| B | Bronzo | Bronze |

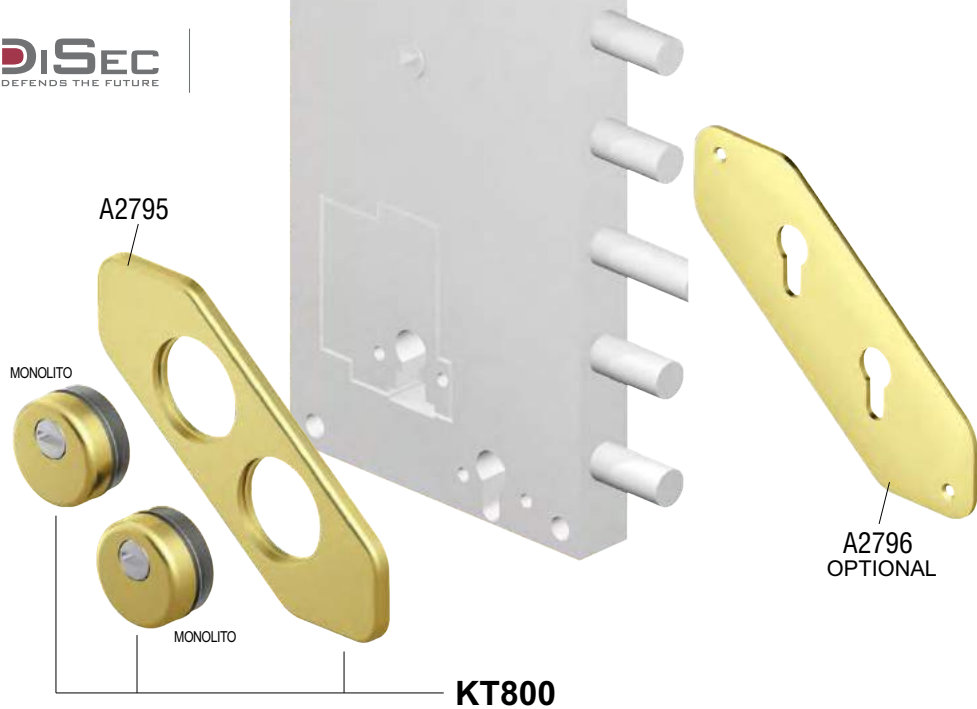

KT80

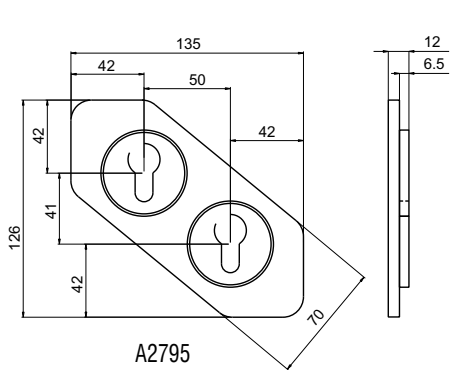

A2795

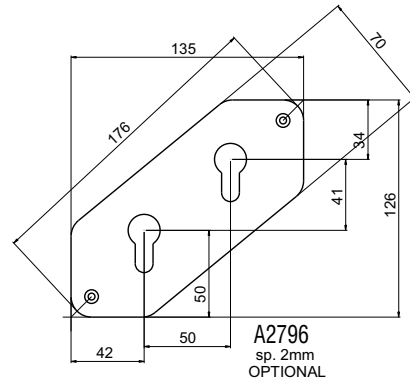

A2796
sp. 2mm
OPTIONAL

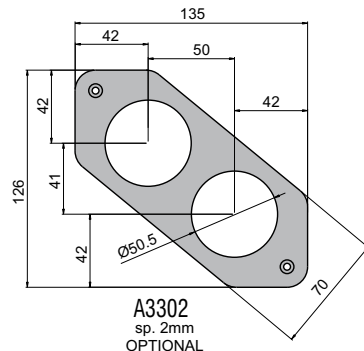

A3302
sp. 2mm
OPTIONAL

FINITURE / FINISHES

- C** Cromo lucido
Bright Chrome
- IT** Inox satinato
Stainless steel
- T** Cromo satinato
Satin Chrome
- 2** PVD Ottonne
PVD Brass
- B** Bronzo
Bronze
- BS** Bronzo satinato
Satin Bronze
- AZ** Ottonne Zapponato
Satin Brass

x FERBONA



A3800 A3805

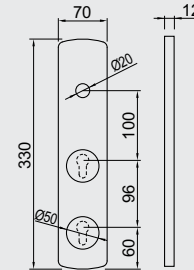

A3801 A3806 A3807 A3808

FINITURE FINISHES

- C** Cromo lucido
Bright Chrome
- T** Cromo satinato
Satin Chrome
- B** Bronzo
Bronze
- 2** PVD Ottonne
PVD Brass
- 9** Oro anodizzato
Anodized Gold
- 6** Argento anodizzato
Anodized Silver

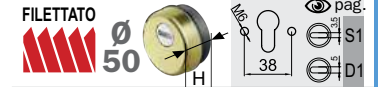
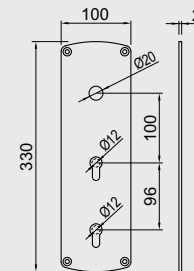

MONOLITO KRYPTON



MONOLITO



MAG ROUND



MRM23



MAG3G



MAG4G



FINITURE FINISHES

- C** Cromo lucido
Bright Chrome
- T** Cromo satinato
Satin Chrome
- B** Bronzo
Bronze
- 2** PVD Ottonne
PVD Brass
- IT** Ottonne satinato
Satin Brass
- BS** Bronzo satinato
Satin Bronze
- IT** Inox satinato
Stainless steel

- C** Cromo lucido
Bright Chrome
- T** Cromo satinato
Satin Chrome
- B** Bronzo
Bronze
- 2** PVD Ottonne
PVD Brass
- IT** Ottonne satinato
Satin Brass
- BS** Bronzo satinato
Satin Bronze
- IT** Inox satinato
Stainless steel

- C** Cromo lucido
Bright Chrome
- T** Cromo satinato
Satin Chrome
- B** Bronzo
Bronze
- 2** PVD Ottonne
PVD Brass
- IT** Ottonne satinato
Satin Brass
- BS** Bronzo satinato
Satin Bronze
- IT** Inox satinato
Stainless steel

- C** Cromo lucido
Bright Chrome
- T** Cromo satinato
Satin Chrome
- B** Bronzo
Bronze
- 2** PVD Ottonne
PVD Brass
- IT** Ottonne satinato
Satin Brass
- BS** Bronzo satinato
Satin Bronze
- IT** Inox satinato
Stainless steel

- C** Cromo lucido
Bright Chrome
- T** Cromo satinato
Satin Chrome
- B** Bronzo
Bronze
- 2** PVD Ottonne
PVD Brass
- IT** Ottonne satinato
Satin Brass
- BS** Bronzo satinato
Satin Bronze
- IT** Inox satinato
Stainless steel

- C** Cromo lucido
Bright Chrome
- T** Cromo satinato
Satin Chrome
- 2** PVD Ottonne
PVD Brass
- IT** Inox satinato
Stainless steel

- C** Cromo lucido
Bright Chrome
- T** Cromo satinato
Satin Chrome
- 2** PVD Ottonne
PVD Brass
- IT** Inox satinato
Stainless steel

X STANDARD

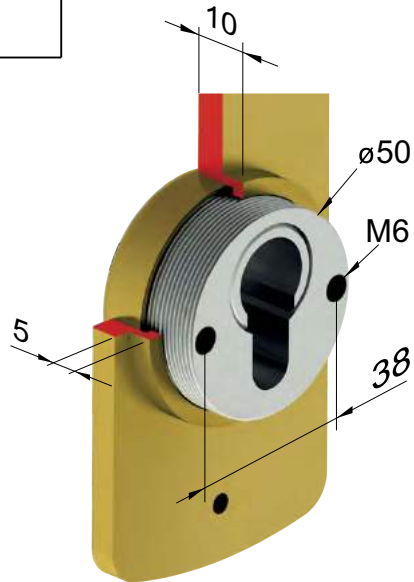
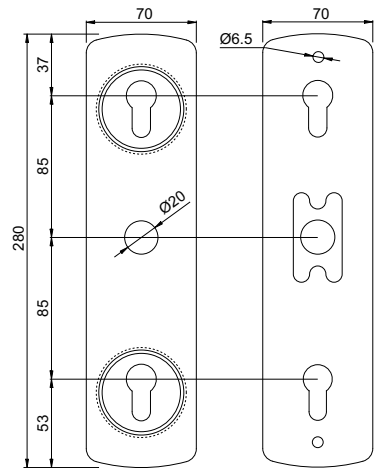
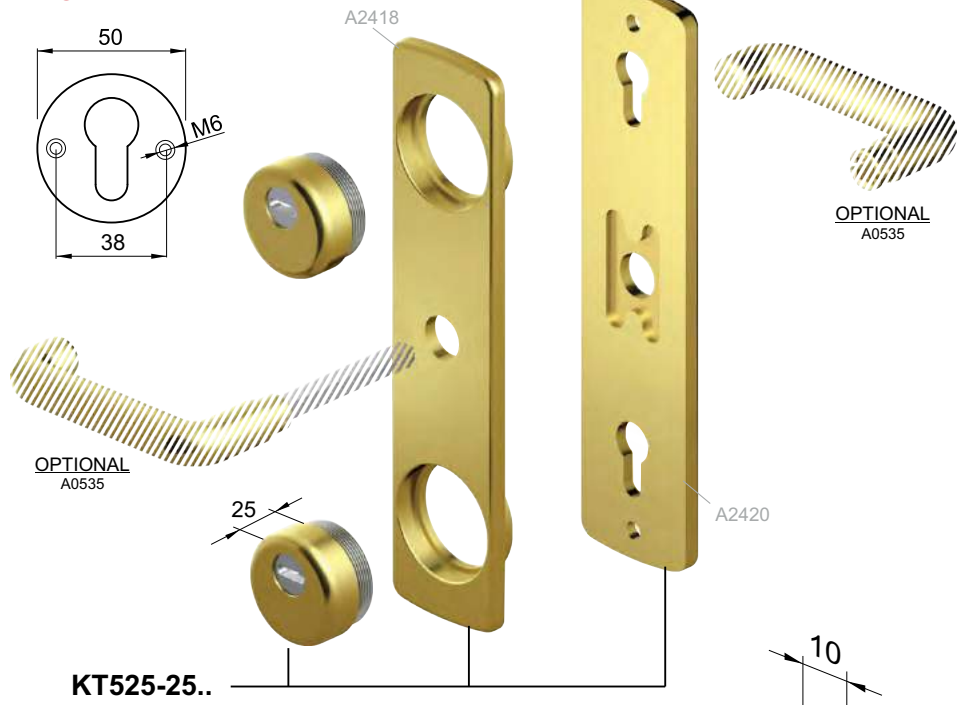

FINITURE / FINISHES

- T Cromo satinato / Satin Chrome
- 2 PVD Ottone / PVD Brass
- B Bronzo / Bronze

X STANDARD

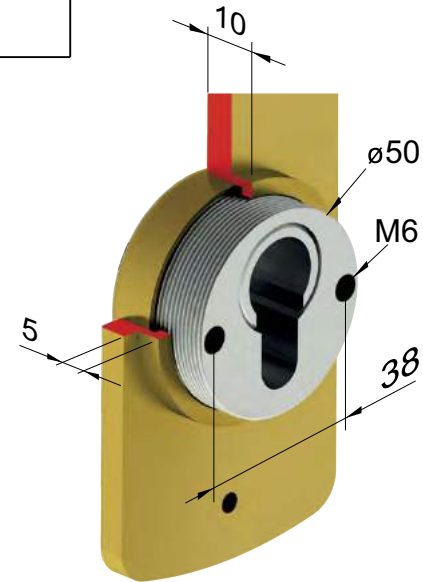
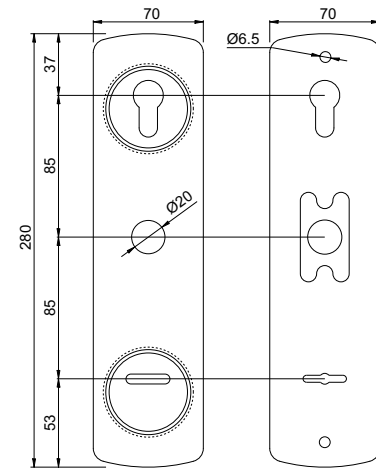
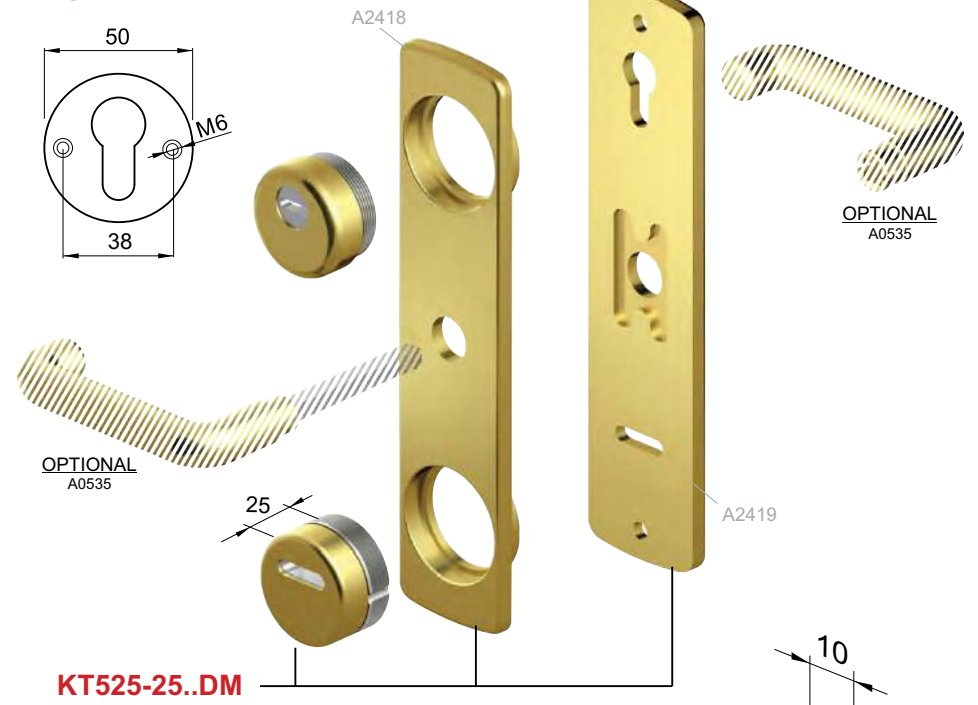

FINITURE / FINISHES

- T Cromo satinato / Satin Chrome
- 2 PVD Ottone / PVD Brass
- B Bronzo / Bronze

X FIAM 868

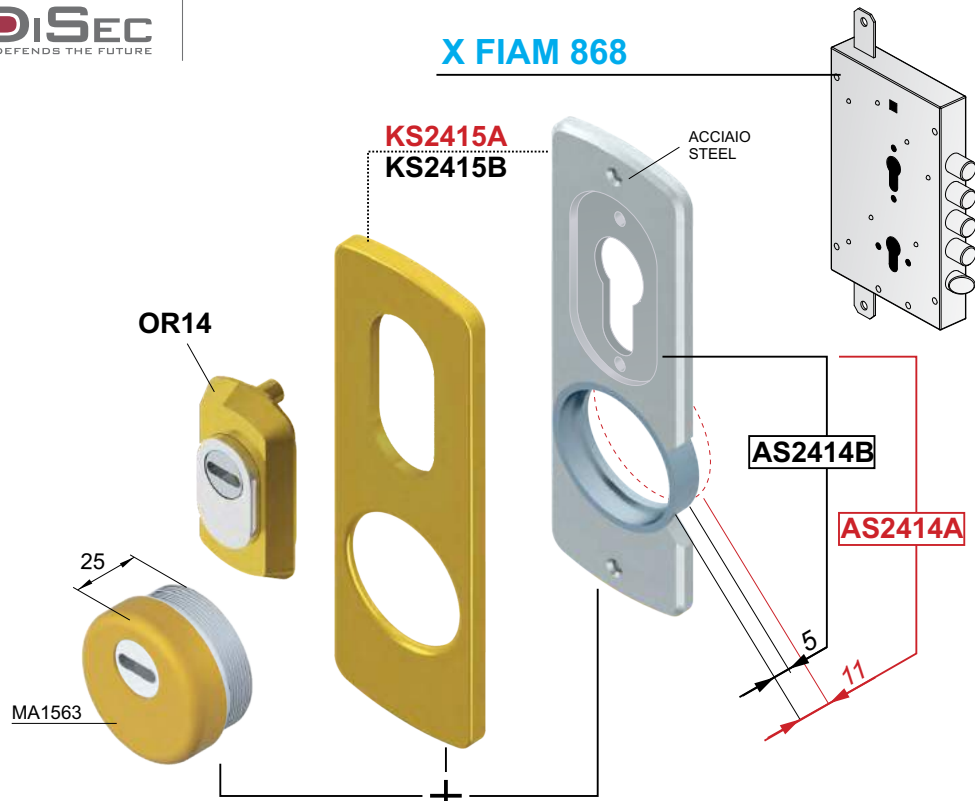

X FIAM 868

**X FIAM
X STANDARD**

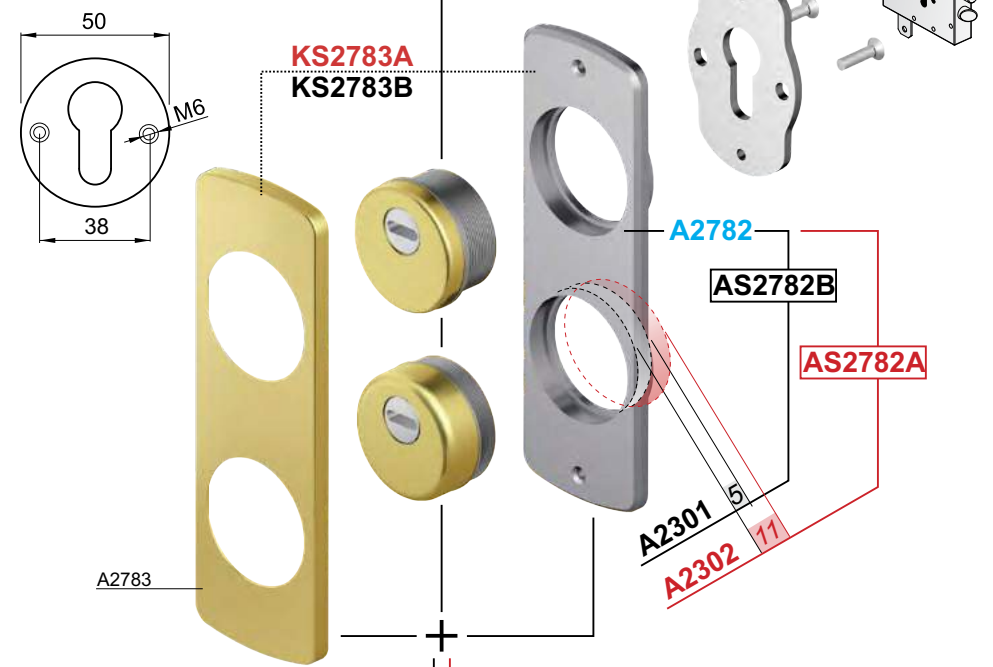

X FIAM

KTB712-25..

KTA712-25..

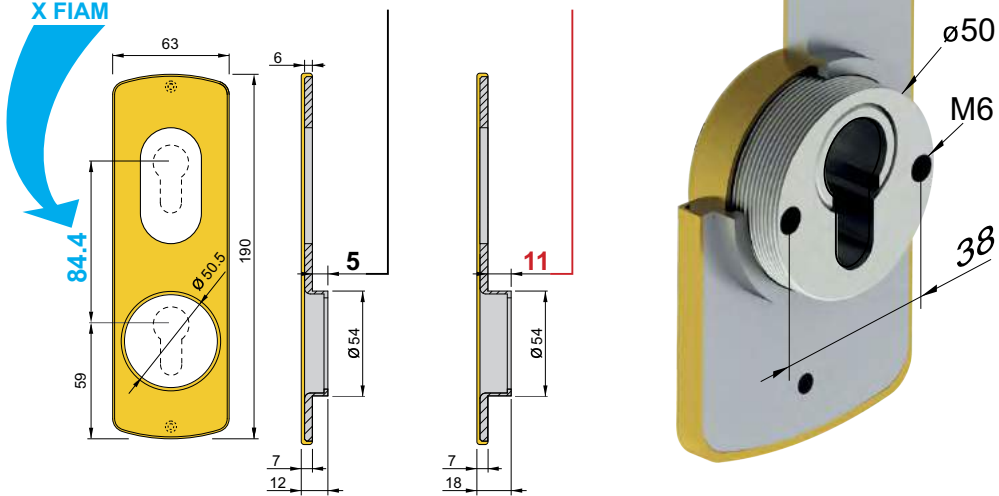

X FIAM

KTB722-25..

KTA722-25..

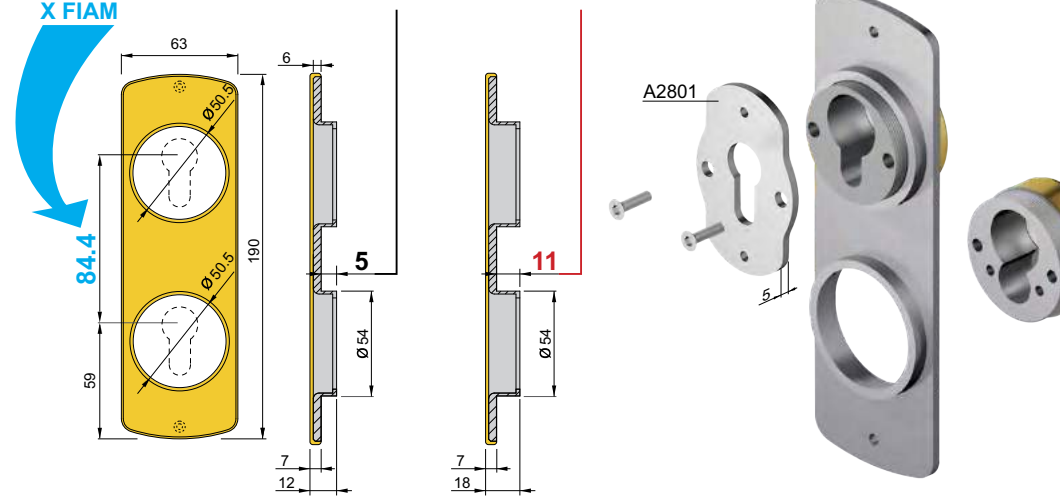

FINITURE / FINISHES

- C Cromo lucido / Bright Chrome
- T Cromo satinato / Satin Chrome
- B Bronzo / Bronze
- 12 Ottone Zapponato / Satin Brass
- IT Inox satinato / Stainless steel
- 2 PVD Ottone / PVD Brass
- BS Bronzo satinato / Satin Bronze

FINITURE / FINISHES

- C Cromo lucido / Bright Chrome
- T Cromo satinato / Satin Chrome
- B Bronzo / Bronze
- 12 Ottone Zapponato / Satin Brass
- IT Inox satinato / Stainless steel
- 2 PVD Ottone / PVD Brass
- BS Bronzo satinato / Satin Bronze

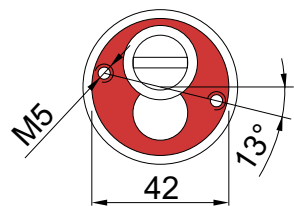

x CR 2155PE

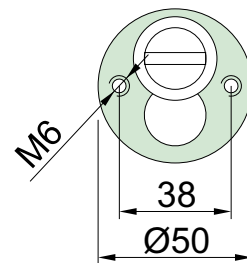
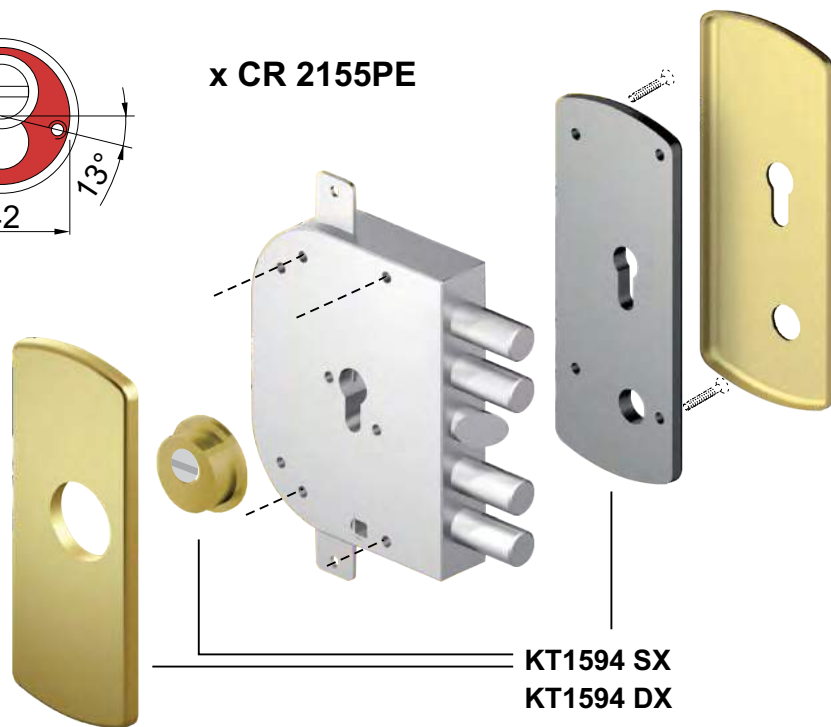

x CR SERIE 21 PE N
x MOTTURA

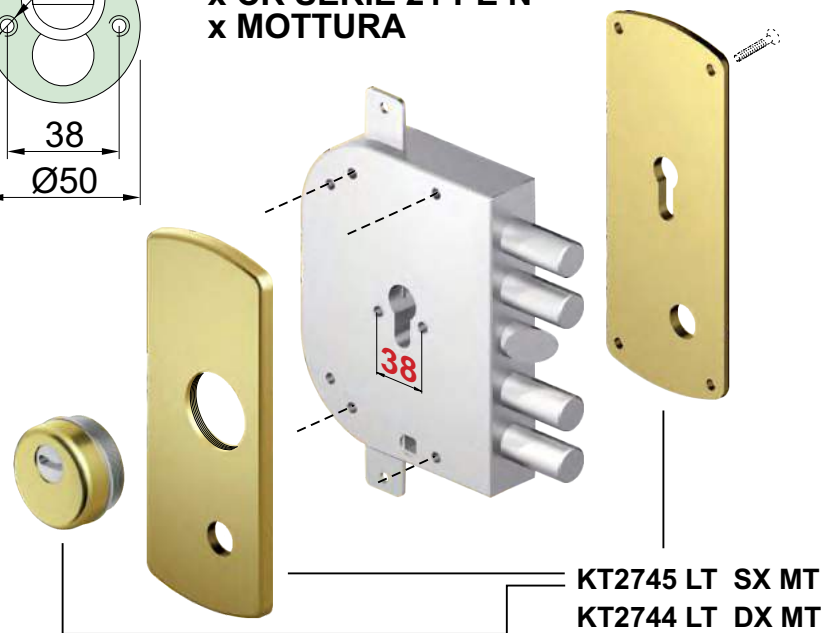

DX

SX

DX

SX

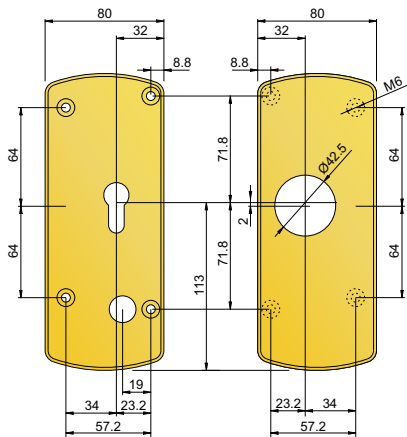

dx CR 2155PE
sp 6mm A1597

dx CR 2155PE
sp 8mm A1596

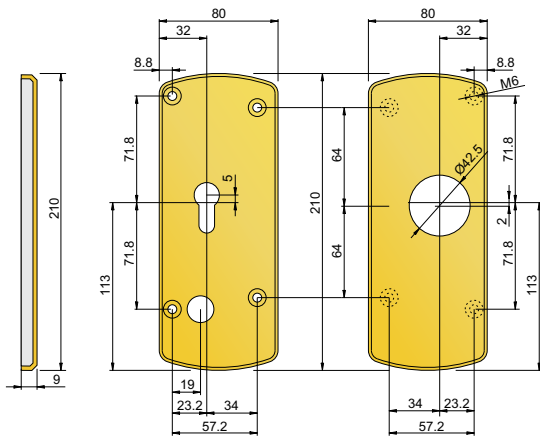

sx CR 2155PE
sp 6mm A1595

sx CR 2155PE
sp 8mm A1594

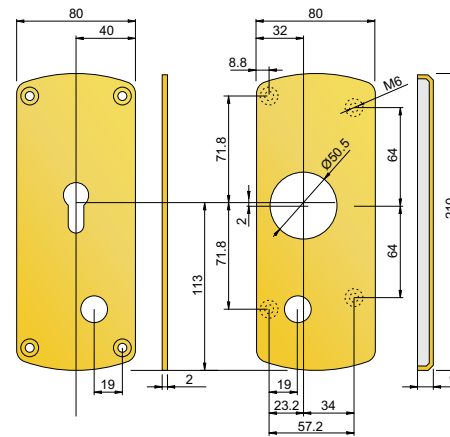

dx CR 21 PE N
A2750 DX

dx CR 21 PE N
Ki2744

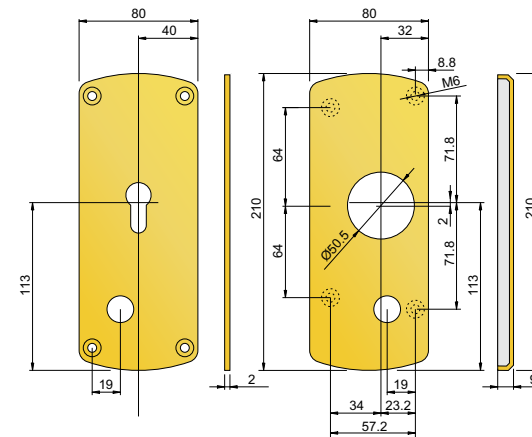

sx CR 21 PE N
A2750 SX

sx CR 21 PE N
Ki2745

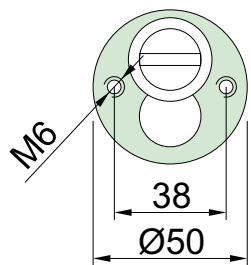

x CR SERIE 21 PE N
x MOTTURA

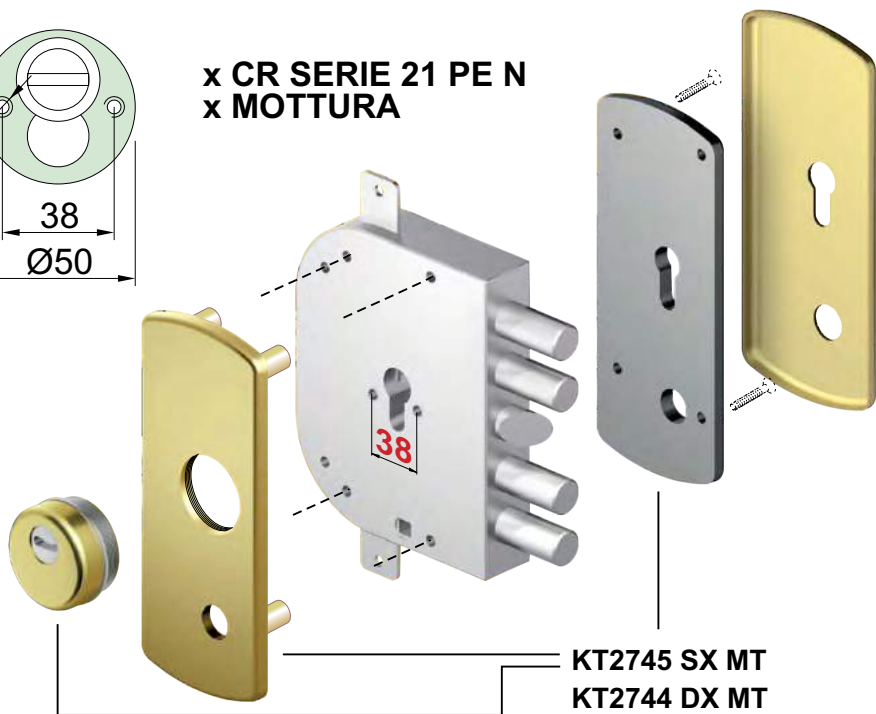

KT2745 SX MT
KT2744 DX MT

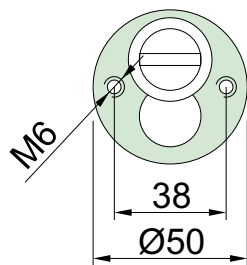

x CR SERIE 21 PE N
x MOTTURA



KT2785 LT SX MT
KT2784 LT DX MT

DX

SX

DX

SX

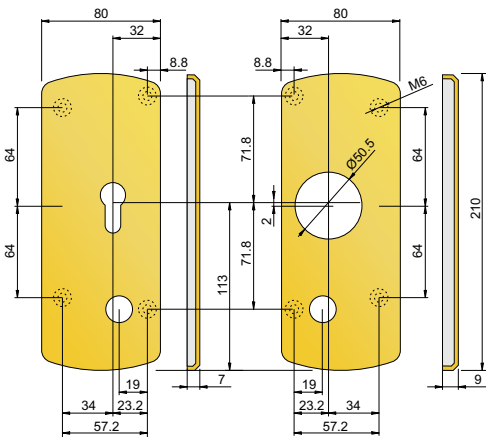

dx CR 21 PE N
Ki2774

dx CR 21 PE N
Ki2744

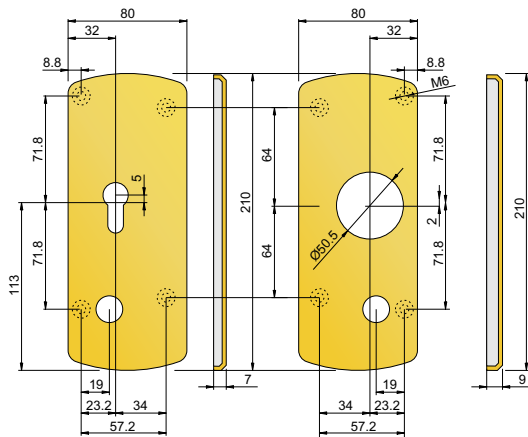

sx CR 21 PE N
Ki2775

sx CR 21 PE N
Ki2745

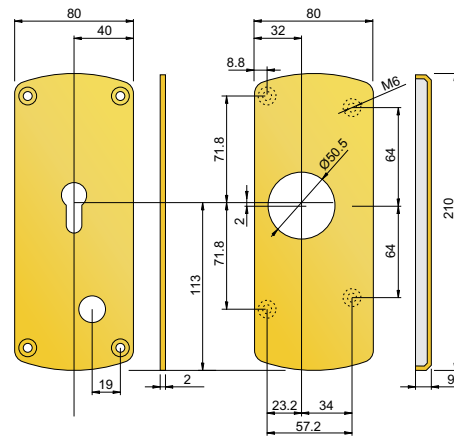

dx CR 21 PE N
A2750 DX

dx CR 21 PE N
Ki2784

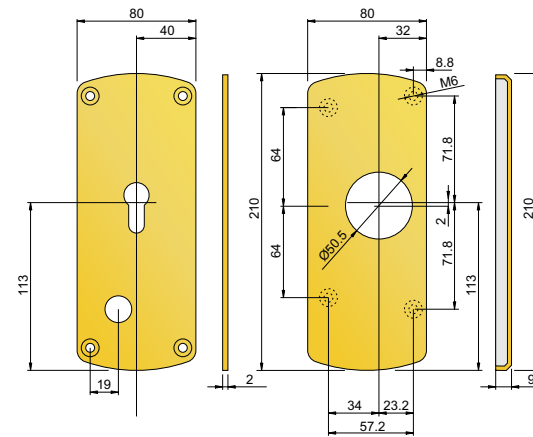

sx CR 21 PE N
A2750 SX

sx CR 21 PE N
Ki2785

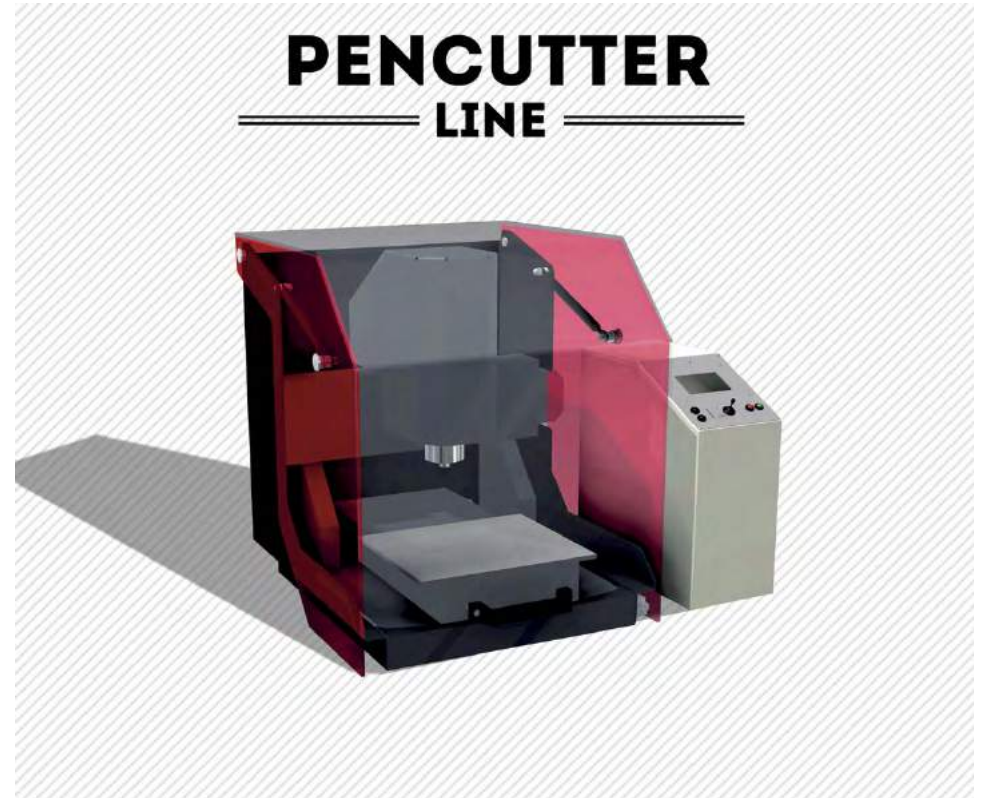
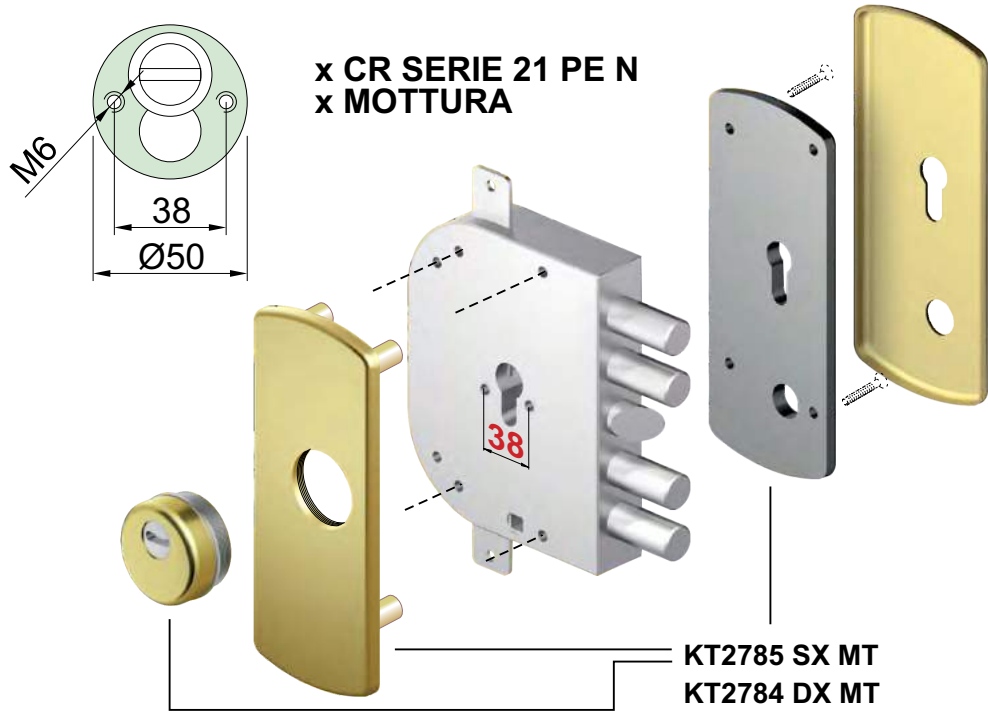

DX

SX

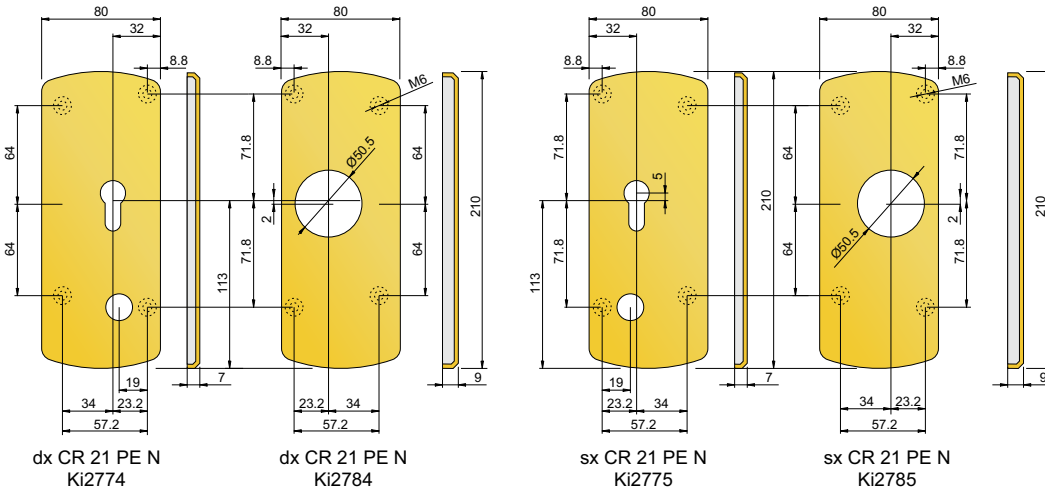



T

Cromo satinato
Satin chrome



iT

Inox satinato
Stainless steel

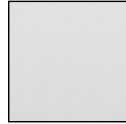

W

Bianco (RAL 9010)
White (RAL 9010)



6

Alluminio silver
Silver aluminium

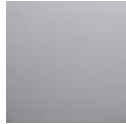

C

Cromo lucido
Polished chrome



N

Nero
Black



9

Alluminio oro
Gold aluminium



L

Ottone lucido
Polished brass

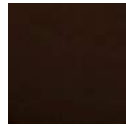

M

Marrone
Brown



A

Alluminio champagne
Champagne aluminium



BS

Bronzo satinato
Satin bronze



2

PVD ottone
PVD bright brass



TT

Ottone satinato
Satin brass



B

Bronzo
Bronze

DISEC S.R.L.
Prodotti Sicurezza

Via Enrico De Nicola, 2
31058 Susegana (TV)
ITALY

+39 0438 453040
www.disec.it
disec@disec.it